

88 5061 761 Storage Stand

IMPORTANT NOTE

Carefully remove all the parts from the carton and put them individually on a soft cloth to prevent scratches or other damage occurring to the parts.

We have taken great care in the design of this product and request that you carefully and strictly follow our assembly instructions to ensure a completed product as it was designed.

*Home
Styles*

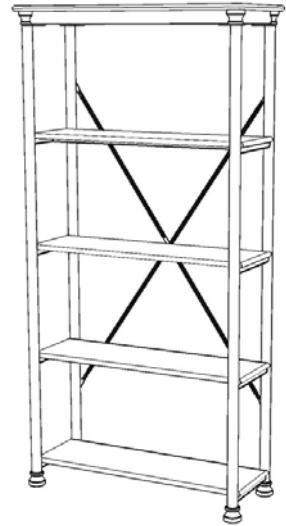

Part List (in this carton)

B.
Side Frame
1 pc.

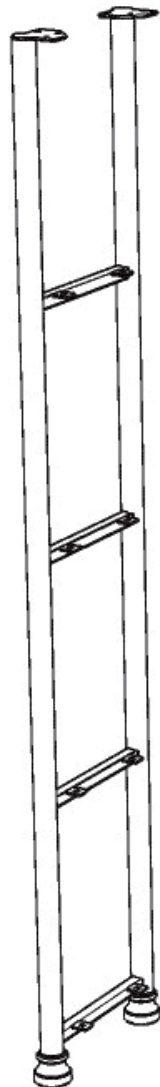

C.
Side Frame
1 pc.

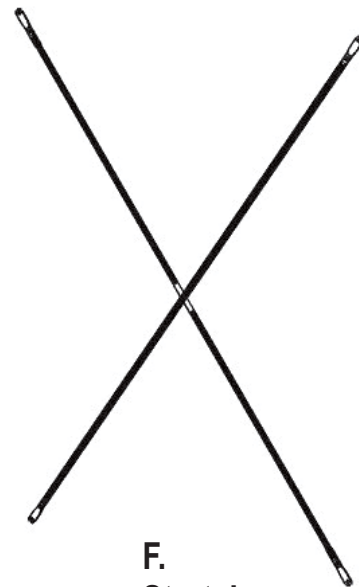
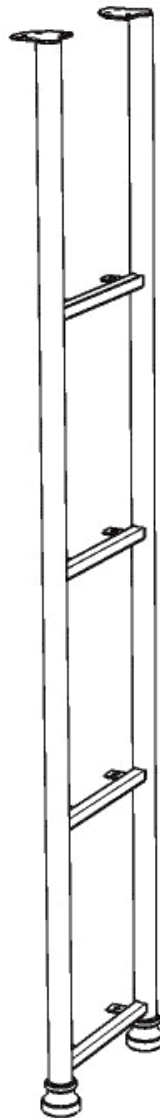

F.
Stretcher
1 pc.

For assembly see instructions in carton 88 5061 762

Tools required for assembly : Phillips screwdriver, Drill, 3/8" Drill Bit, Level

Home Styles Consumer Assistance: www.homestyles-furniture.com,
servicedesk@homestyles-furniture.com, 888-680-7460, 877-831-0319

88 5061 762 Storage Stand

IMPORTANT NOTE

Carefully remove all the parts from the carton and put them individually on a soft cloth to prevent scratches or other damage occurring to the parts.

We have taken great care in the design of this product and request that you carefully and strictly follow our assembly instructions to ensure a completed product as it was designed.

*Home
Styles*

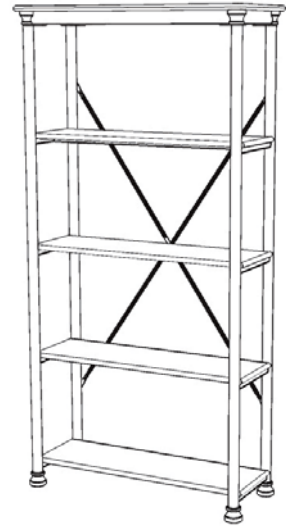

Part List (in this carton)



A.
Top
1 pc.



D.
Shelf
4 pcs.



E.
Support
4 pcs.

Hardware List



Hex Wrench
1 pc.



Spring Washer
20 pcs. (+1 extra)



**M6x16
Head Cap Bolt**
20 pcs. (+1 extra)



**M4x32
Wood Screw**
12 pcs. (+1 extra)



**Small
Hex Wrench**
1 pc.



Flat Washer
20 pcs. (+1 extra)



**M6x12
Head Cap Bolt
(short)**
12 pcs. (+1 extra)

Also need the Parts in carton 88 5061 761

Tools required for assembly : Phillips screwdriver, Drill, 3/8" Drill Bit, Level

Home Styles Consumer Assistance: www.homestyles-furniture.com,
servicedesk@homestyles-furniture.com, 888-680-7460, 877-831-0319

Assembly Instructions 2/4

IMPORTANT

- * Do not tighten all the Head Cap Bolts until each part is properly assembled.
- * You should keep Hex Wrench in a safe place as you may need to tighten up the Head Cap Bolts in the future.
- * After assembly, item must be level to work properly. Use the included adjustable levelers to level.

STEP 1

Place Top (A) upside down on a soft cloth.

Attach Side Frames (B) and (C) to Top (A) with Head Cap Bolts (short), tightening the bolts only half way. (See Figure 1)

Attach Stretcher (F) to unit with Flat Washers, Spring Washers and Head Cap Bolts, tightening the bolts only half way. (See Figure 2)

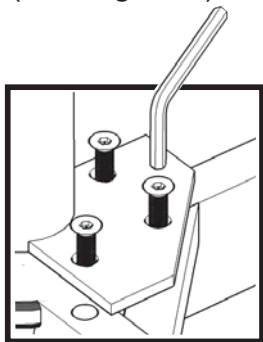
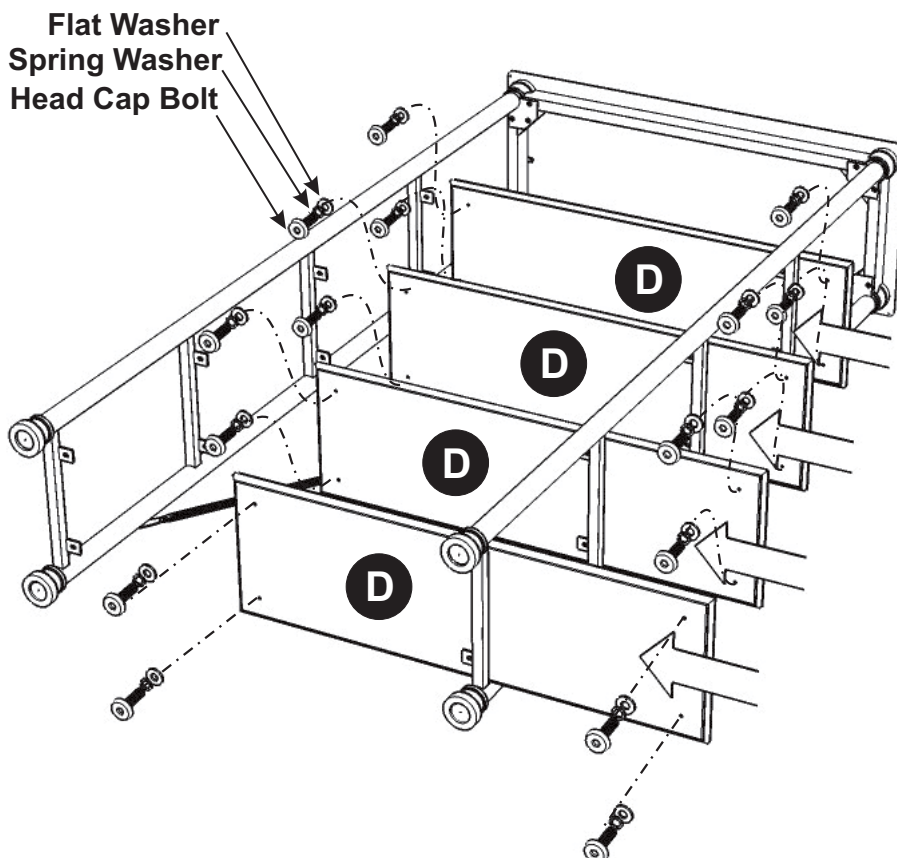
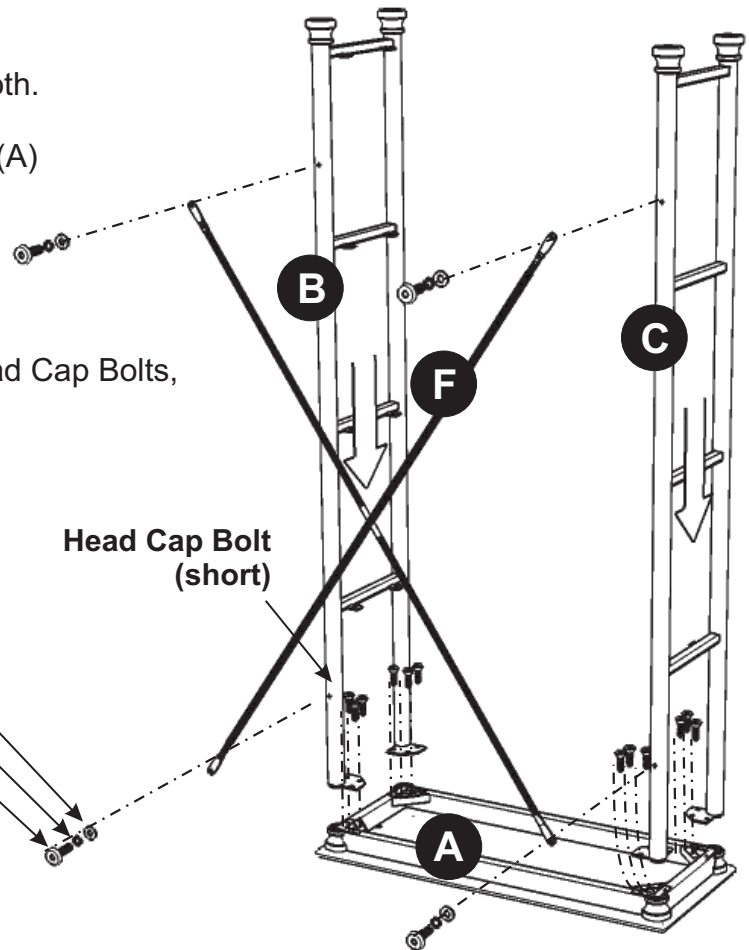

Figure 1



STEP 2

Attach Shelves (D) to unit with Flat Washers, Spring Washers and Head Cap Bolts, tightening the bolts only half way.

Tighten all Head Cap Bolts used in Steps 1 and 2.

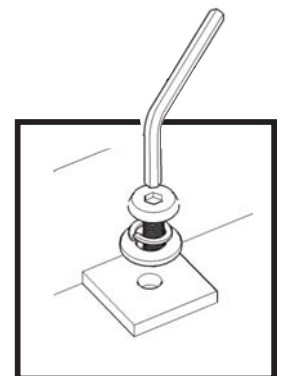
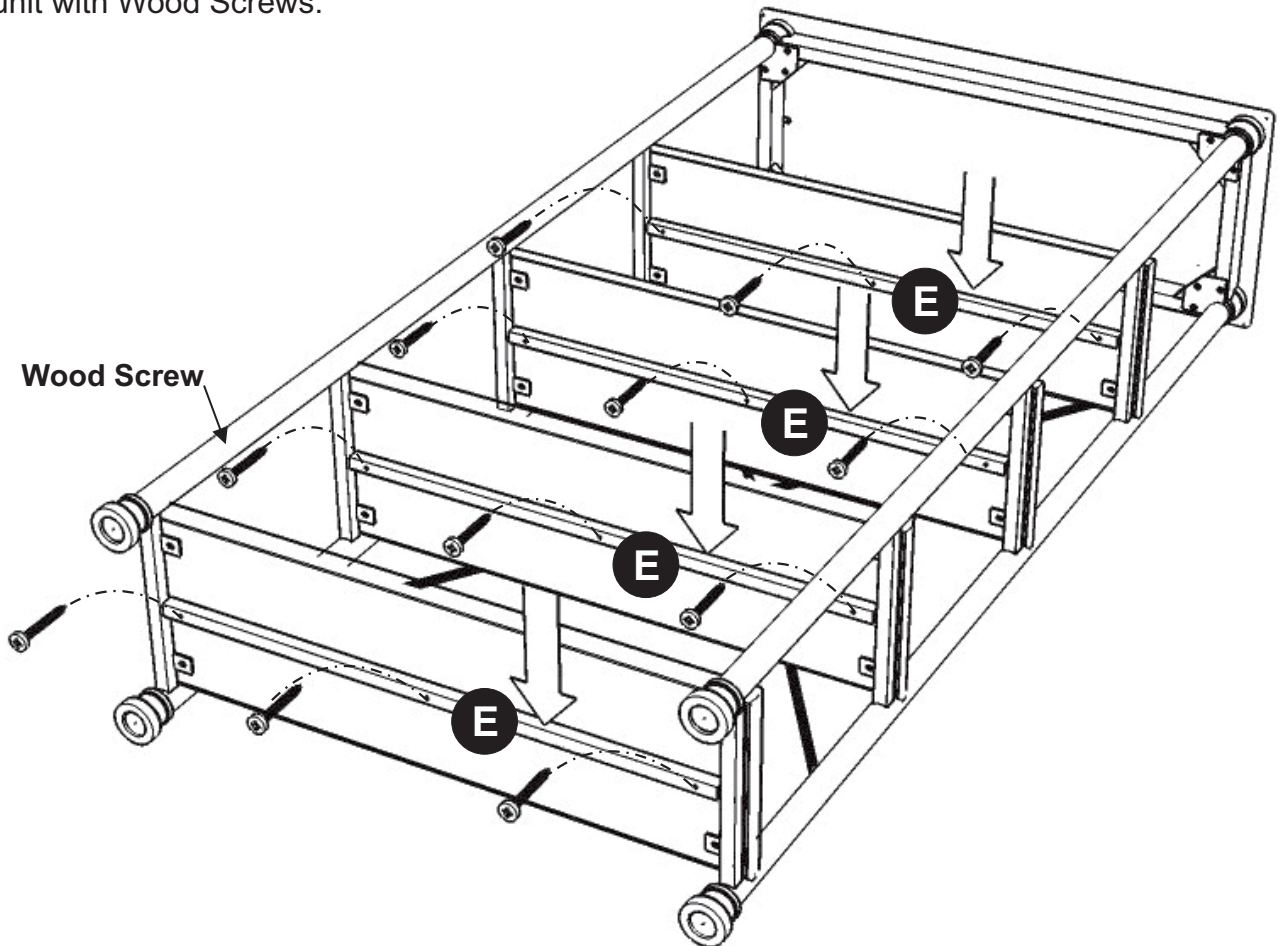

Figure 2

STEP 3

Attach Supports (E)
to unit with Wood Screws.



STEP 4

Turn the unit over to its' upright position.
To level the unit, adjust the adjustable
levelers on the bottom of unit. (See Figure 3)

Note: Unit must be level to work properly.

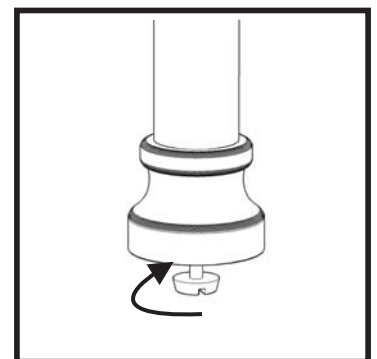

(Figure 3)

Attention!

To help reduce the risk of the unit tipping over, the Tipover Restraint must be installed following these instructions exactly!

Place unit at desired location.

Drill a 3/8" hole in wall at the appropriate location.

Insert Anchor into the wall hole and attach Bracket with Wall Screw.

Attach Bracket at pre-drilled hole at top of unit with Machine Screw.

Use Tipover Restraint to secure Bracket on unit to Bracket on wall.

(See Figure X)

Put tie end of Tipover Restraint into loop end of Tipover Restraint and pull until tight.

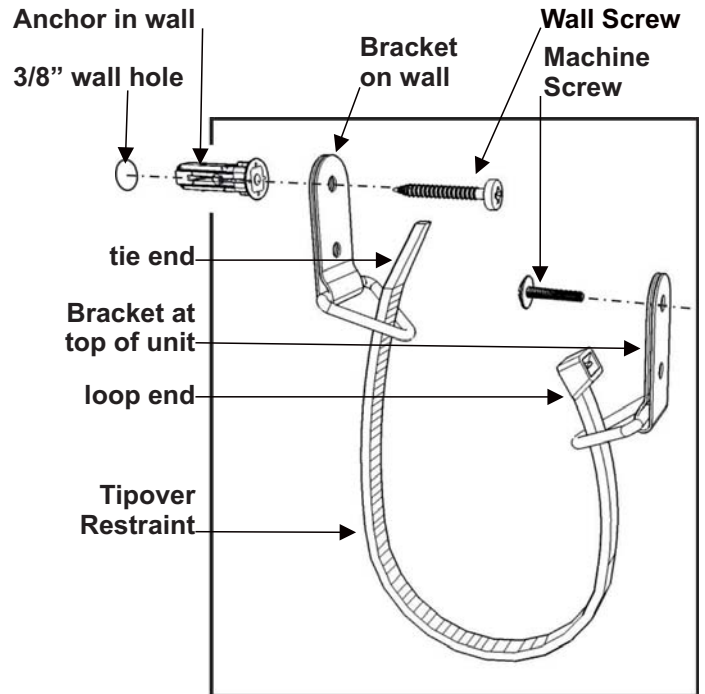
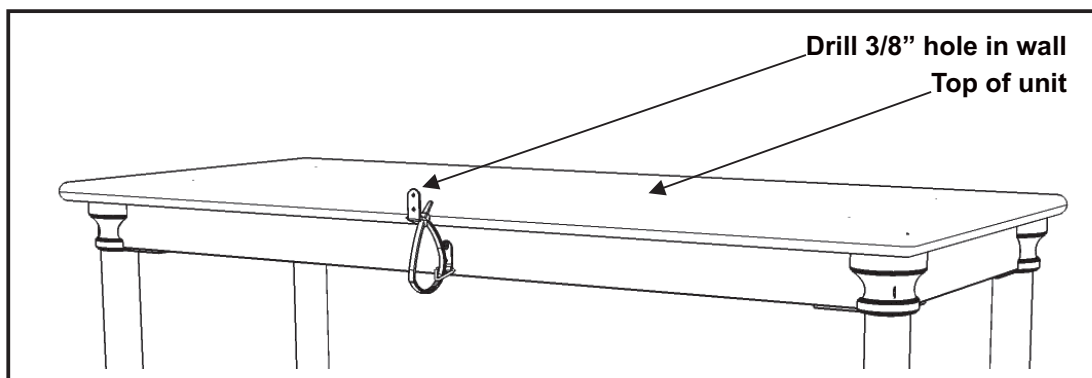
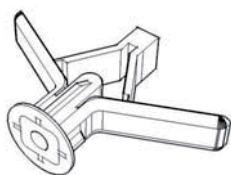

Figure X



Hardware List



Anchor
1 pc.(+1 extra)

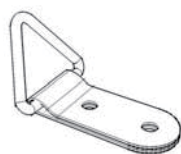

Bracket
2 pcs.(+1 extra)

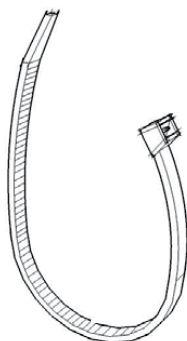

Tipover Restraint
1 pc.(+1 extra)

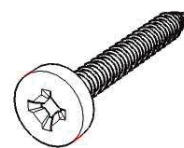

**M3.5x40
Wall Screw**
1 pc.(+1 extra)



**M4x16
Machine Screw**
1 pc.(+1 extra)