

Use and Care Guide SOLAR STEP LIGHTS

Please read and save these instructions

PACKAGE CONTENTS

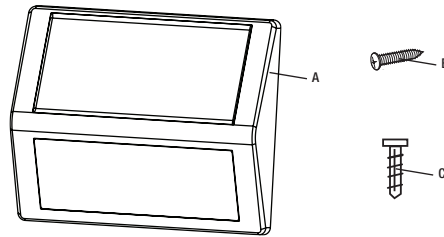

Part	Description	Quantity
A	Solar Wall Lights	4
B	Screws	8
C	Anchors	8

Assembly and Installation

NOTE: If the solar panel is covered by a protective film, remove it before using the product. Remove the pull-tab from the battery door. Place the solar light in a location where it can receive a full 8 hours of sunlight to allow the rechargeable battery/batteries to reach maximum capacity.

1 Attaching and installing the light

- Using the 2X screws and 2X anchors supplied, install the unit (A). Screws should be installed to match the 2 slots in the rear of the unit (A).

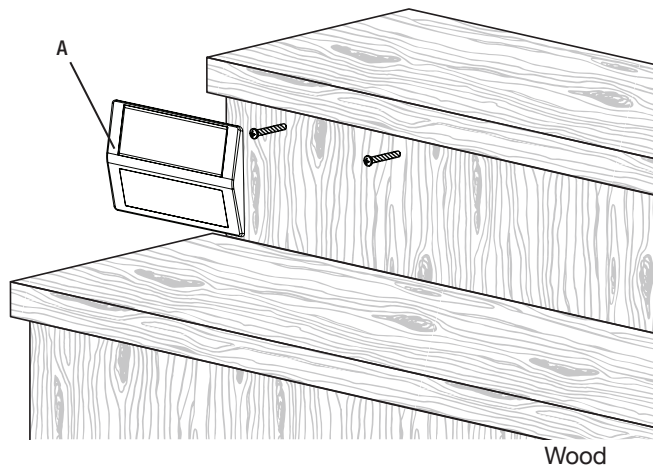

Wood

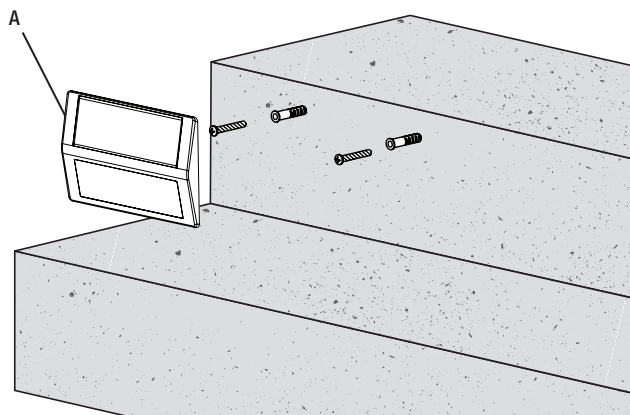

Concrete

2 Replacing the battery

NOTE: This operation should be done in the morning on a sunny day. This will allow the light to receive a full 8 hours of sunlight so that the rechargeable battery can reach maximum capacity.

- Remove the 4 battery cover screws.
- Remove the battery cover.
- Remove the old battery and replace with 1 new AA NiMh rechargeable battery of same or greater mAh. **USE RECHARGEABLE BATTERIES ONLY.**

Note: Clean the battery contacts and those of the device prior to battery installation.

- Be sure to insert the battery in proper direction.
- Replace the battery cover.
- Replace the 4 screws.

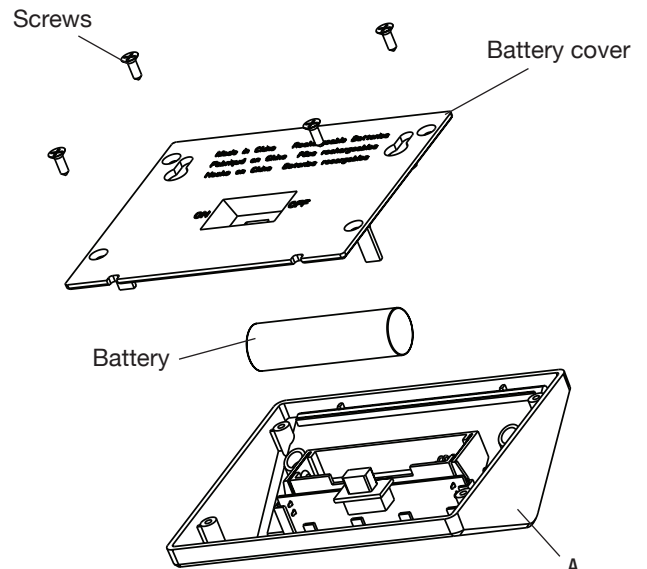

Care and Cleaning

- Clean the fixture with a soft, dry cloth.
- Do not use any cleaners with chemicals, solvents or harsh abrasives.

Troubleshooting

If the light does not turn on at dusk after 8 hours of charging :

- Ensure that the solar accent wall light is in a bright sunny location and not in a shady area during the day.
- Make sure that the light's solar panel is not near any other light sources at night.
- Ensure that the ON/OFF switch is in the ON position.
- Verify that the battery/batteries are making contact with the terminal and that they have been inserted in the correct polarity.

Warranty

WHAT IS COVERED

The manufacturer warrants this lighting fixture to be free from defects in materials and workmanship for a period of two (2) years from the date of purchase. This warranty applies only to the original consumer and only to products used in normal use and service. If this product is found to be defective, the manufacturer's only obligation, and your exclusive remedy, is the repair or replacement of the product at the manufacturer's discretion, provided that the product has not been damaged through misuse, abuse, accident, modifications, alterations, neglect or mishandling.

WHAT IS NOT COVERED

This warranty shall not apply to any product that is found to have been improperly installed, set-up, or used in any way not in accordance with the instructions supplied with the product. This warranty shall not apply to a failure of the product as a result of an accident, misuse, abuse, negligence, alteration or faulty installation, or any other failure not relating to faulty material or workmanship. This warranty shall not apply to the finish on any portion of the product, such as surface and/or weathering, as this is considered normal wear and tear.

The manufacturer does not warrant and specially disclaims any warranty, whether express or implied, of fitness for a particular purpose, other than the warranty contained herein. The manufacturer specifically disclaims any liability and shall not be liable for any consequential or incidental loss or damage, including but not limited to any labor / expense costs involved in the replacement or repair of said product.

Contact the Customer Service Team at 1-855-HD-HAMPTON or visit www.hamptonbay.com.
