

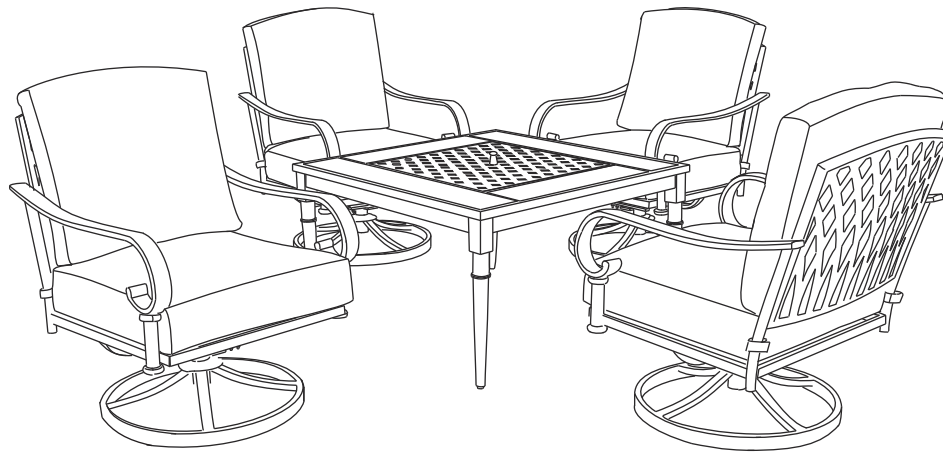

Item # 742 481
Model #176-411-5FP-V2

USE AND CARE GUIDE

OAK CLIFF 5-PIECE PATIO FIRE PIT CONVERSATION SET (Box 1 of 3: Two Chairs)



Questions, problems, missing parts? Before returning to the store,
call Hampton Bay Customer Service
8.00 a.m. - 7.00 p.m. EST, Monday - Friday,
9.00 a.m. - 6.00 p.m. EST, Saturday

1-855-HD-HAMPTON

HAMPTONBAY.COM

THANK YOU

We appreciate the trust and confidence you have placed in Hampton Bay through the purchase of this 5 piece set. We strive to continually create quality products designed to enhance your home. Visit us online to see our full line of products available for your home improvement needs. Thank you for choosing Hampton Bay!

Table of Contents

Table of Contents.....	2	Pre-Assembly.....	3
Safety Information.....	2	Planning Assembly.....	3
Warranty.....	2	Hardware Included.....	3
2 Year Frame and Fabric Limited Warranty.....	2	Package Contents.....	4
What Is Covered .. .	2	Assembly	5
What Is Not Covered .. .	2		
Care Instructions.....	2		

Safety Information



CAUTION: Please keep children out of the assembly area during assembly.



WARNING: The chair will fall if over-rocking. The chair will make noise if bolts are not fully tightened.



CAUTION: Use the chairs on flat ground only.



IMPORTANT: Please check the tightness of the bolts at least every 90 days.

Warranty

2 YEAR FRAME / 2 YEAR FABRIC LIMITED WARRANTY

WHAT IS COVERED

We warrant the frame to be free of manufacturing defects to the original purchaser for two years and the fabric for two years.

WHAT IS NOT COVERED

It remains the customer's responsibility for freight and packaging charges to and from our service center. This warranty does not cover commercial use, hardware, acts of nature, fire, freezing and abusive use. In addition, purchased parts are not covered under this warranty. We reserve the right to make substitutions with similar merchandise, if the model in question is no longer in production.

Care Instructions

Before using, wipe with a clean, dry cloth. Do not use bleach or solvents. Treat frame with one step liquid wax for maximum protection against UV light and salty, damp air. When not in use, store furniture in a cool, dry place. If your set includes cushions, they may be cleaned by hand with a mild solution of soap and water. Rinse cushion thoroughly and allow to drip dry. Do not machine wash or tumble dry, as cushions may shrink. Do not use bleach or solvents on fabrics.

You may contact our customer service department with any questions by phone at 1-855-HD-HAMPTON or visit www.hamptonbay.com.

Pre-Assembly

PLANNING ASSEMBLY

It will take two people about 20 minutes to complete the assembly process.

HARDWARE INCLUDED



NOTE: Hardware not shown to actual size.

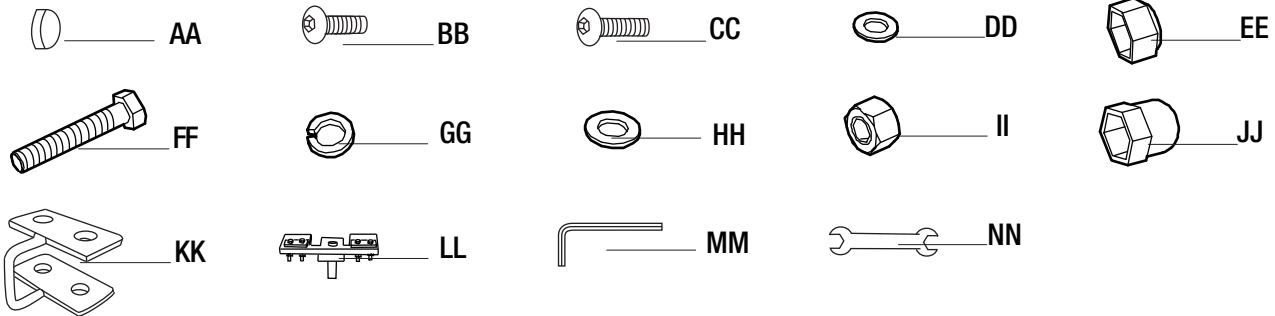

Part	Description	Quantity
AA	Bolt cap (M6)	16
BB	Bolt (M6x30)	8
CC	Bolt (M6x35)	8
DD	Washer (M6)	16
EE	Bolt cap (M8)	16
FF	Bolt (M8x40)	8
GG	Lock washer (M8)	8
HH	Washer (M8)	16
II	Nut (M8)	8

Part	Description	Quantity
JJ	Nut cap (M8)	16
KK	Washer plate	4
LL	T-rock	2
MM	Hex wrench	1
NN	Spanner	2

Pre-Assembly (continued)

PACKAGE CONTENTS

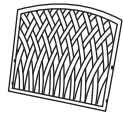

_____ A

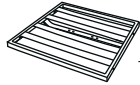

_____ B

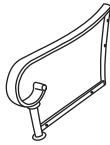

_____ C

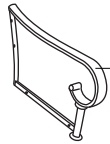

_____ D

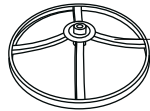

_____ E

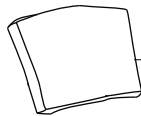

_____ F

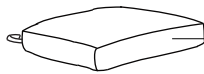

_____ G

Part	Description	Quantity
A	Back panel	2
B	Seat panel	2
C	Right armrest	2
D	Left armrest	2
E	Chair base	2
F	Back cushion	2
G	Seat cushion	2

Assembly

1 Attaching armrests to the seat panel

- Identify the front side and the rear side of the seat panel (B).
- Attach armrests (C) and (D) to the seat panel (B) with washers (DD) and bolts (BB) using hex wrench (MM). (Fig.1)



IMPORTANT: Do not fully tighten bolts until the end of Step 2.

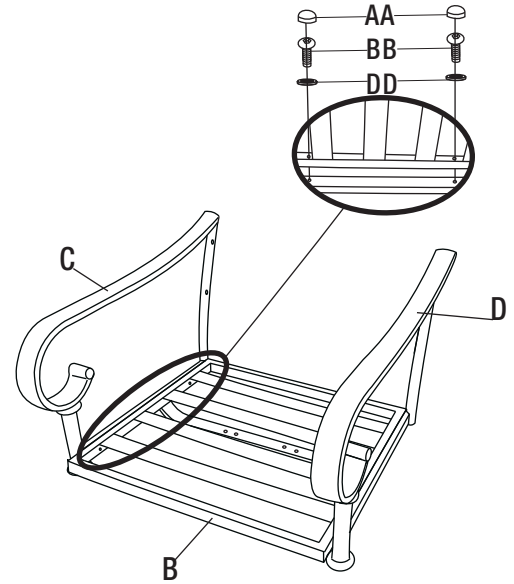
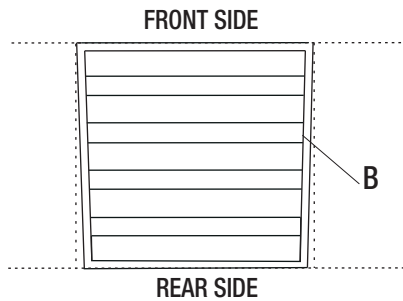

Fig. 1

2 Attaching the back panel

- Attach the back panel (A) to armrests (C) and (D) with washers (DD) and bolts (CC) using hex wrench (MM). (Fig. 2)
- Fully tighten all bolts (CC) and (BB) once all bolts are in place.
- Cover bolts (CC) and (BB) with bolt caps (AA). (Fig.1 & Fig. 2)

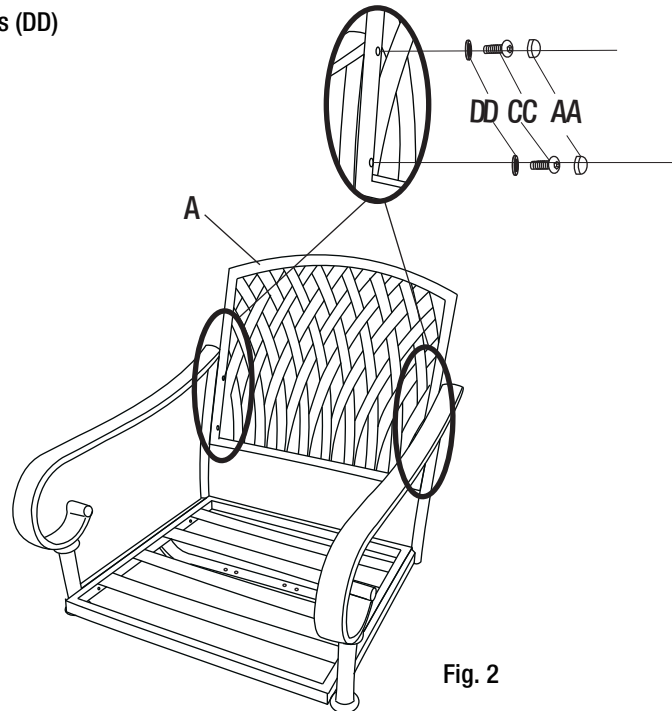
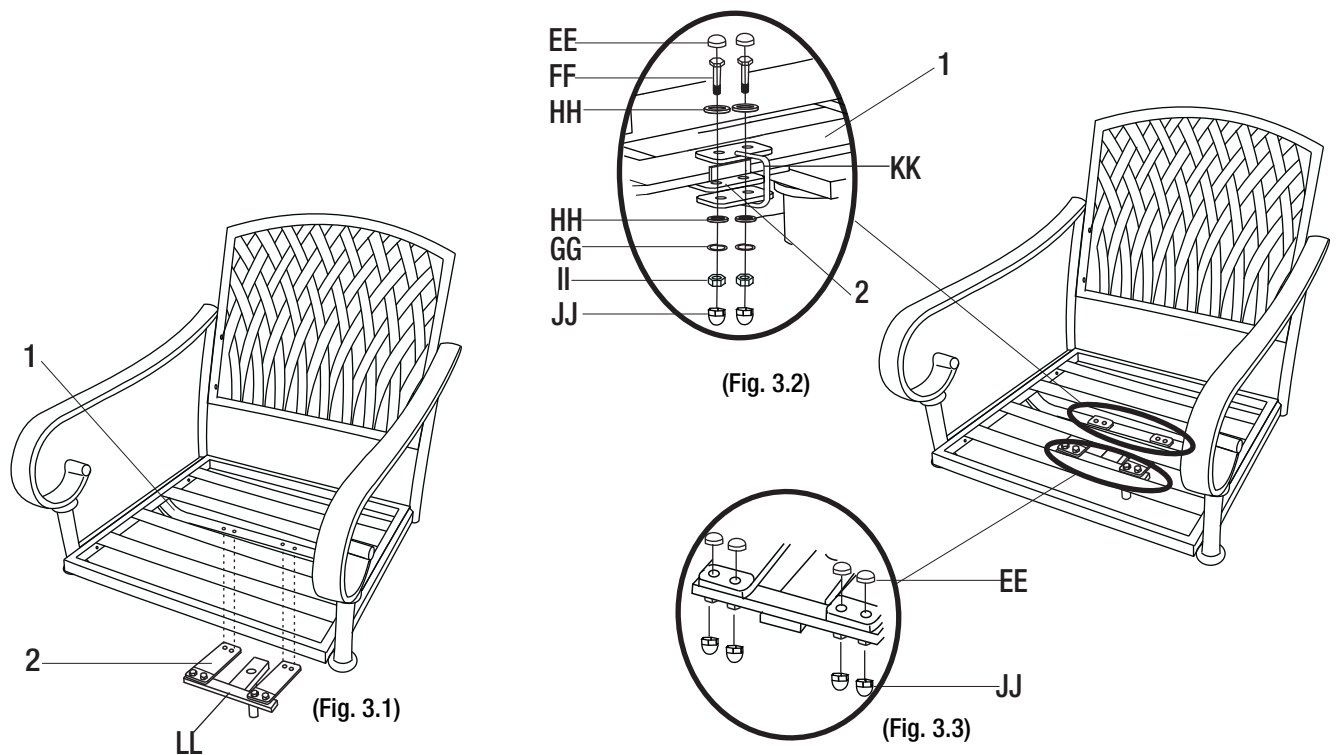

Fig. 2

Assembly (continued)

3 Attaching the T-rock to the chair seat

- Align the T-rock (LL) to the U-bar of the chair seat (A) from underneath the U-bar (1). You may need to loosen pre-installed bolts and nuts. (Fig. 3.1)
- Clamp the rocking plates (2) of the T-rock (LL) and the U-bar (1) of the chair seat (A) together with washer plates (KK). Secure the T-rock (LL), the U-bar and the washer plates (KK) with washers (HH) and bolts (FF) from above the washer plates (KK) and also with washers (HH), lock washers (GG) and nuts (II) from below the washer plates (KK) with spanners (NN). (Fig. 3.2)
- Fully tighten all bolts / pre-installed bolts and nuts / pre-installed nuts once all bolts and nuts are in place.
- Cover all bolts / pre-installed bolts with bolts caps (EE). Cover all nuts / pre-installed nuts with nut caps (JJ). (Fig. 3.2 and Fig 3.3)



4 Attaching the chair base

- Place the chair base on a flat, smooth surface.
- Insert and twist the shaft (3) of the T-rock (LL) into the chair base (E) until the shaft is completely locked into the chair base. The plastic insert in the base should lock the metal shaft and click into place.

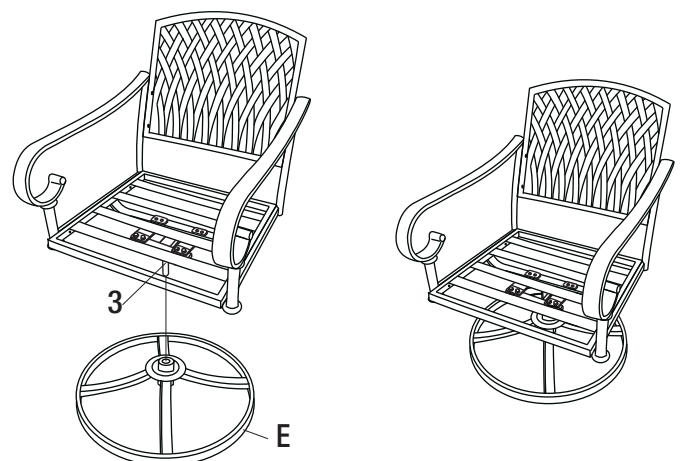

Assembly (continued)

5 Placing cushions

- Place cushions (F) and (G) on the chair.
- Secure the seat cushion (G) on the frame with hook and loop straps.
- Repeat step 1 to 5 for the other chair.

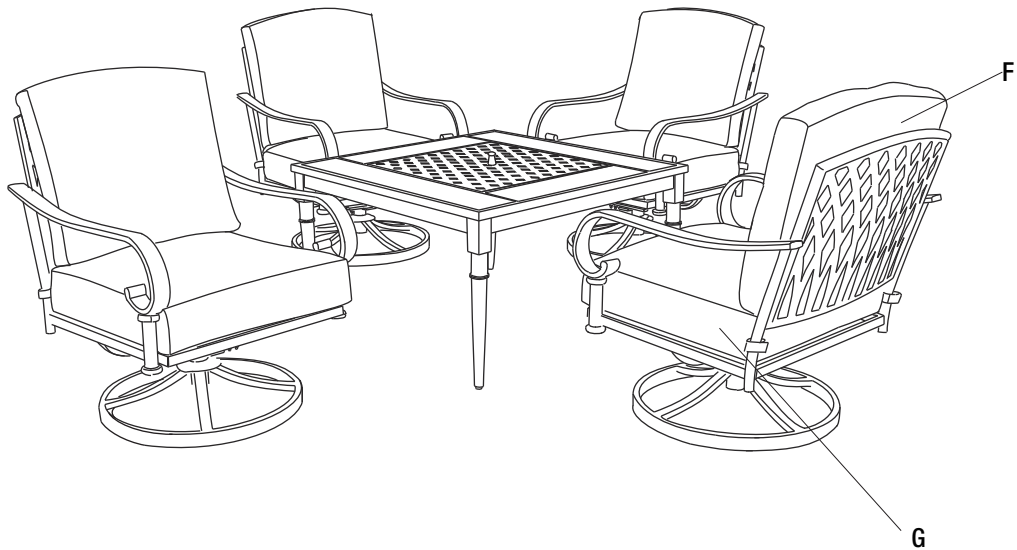



Questions, problems, missing parts? Before returning to the store,
call Hampton Bay Customer Service
8.00 a.m. - 7.00 p.m. EST, Monday - Friday,
9.00 a.m. - 6.00 p.m. EST, Saturday

1-855-HD-HAMPTON

HAMPTONBAY.COM

Retain this manual for future use.