

19962-▲SD-DST

19962-▲SD-DST with optional escutcheon

Submitted Model No.: _____

Specific Features: _____

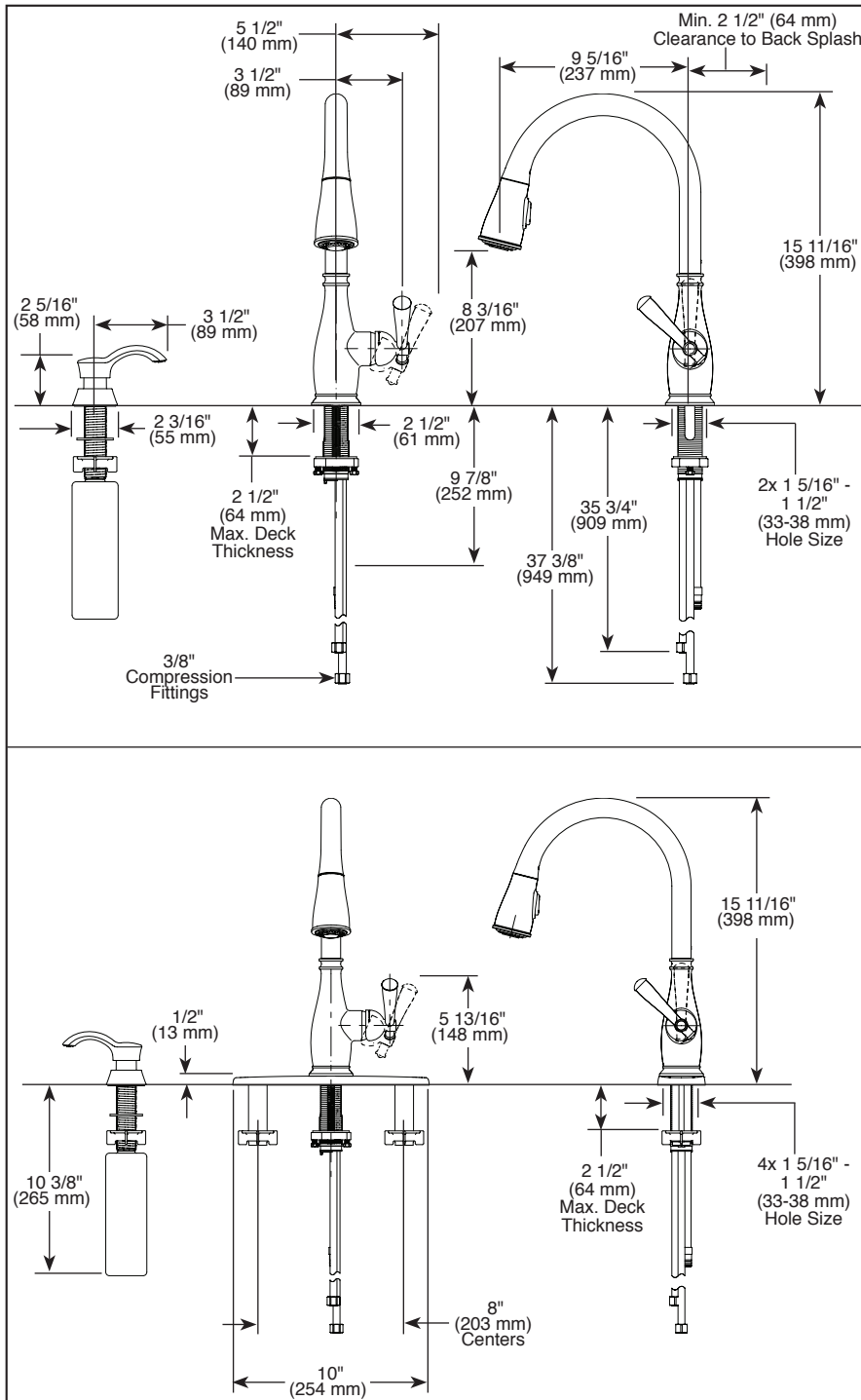

▲ Designate proper finish suffix

Delta reserves the right (1) to make changes in specifications and materials, and (2) to change or discontinue models, both without notice or obligation. Dimensions are for reference only. See current full-line price book or www.specselect.com for finish options and product availability.



KITCHEN FAUCETS

- Charmaine™ Collection
- Single Handle Pull-Down

FEATURES:

- Touch-Clean® Technology
- DIAMOND Seal® Technology
- MagnaTite® Docking System
- Quick Snap® hose installation

STANDARD SPECIFICATIONS:

- Maximum 1.80 gpm @ 60 psi, 6.8 L/Min @ 414 kPa
- One, two, three or four hole mount (escutcheon optional, included)
- Diamond coated ceramic cartridge
- 3/8" O.D. straight, staggered PEX supply lines
- Spout rotates 360°
- Hot/cold indicator markings
- Two-function wand; aerated stream or spray
- Dual integral check valves in sprayer assembly
- Soap dispenser with 8 oz reservoir (optional included)

WARRANTY

- Lifetime limited warranty on parts (other than electronic parts and batteries) and finishes; or, for commercial users, for 5 years from date of purchase.
- 5 Year limited warranty on electronic parts (other than batteries); or, for commercial users, for 1 year from the date of purchase. No warranty is provided on batteries.

COMPLIES WITH:

- ASME A112.18.1 / CSA B125.1
- ASME A112.18.6
- ICC/ANSI A117.1
- Verified compliant with .25% weighted average Pb content regulations.

