

## UP166F CHEST PRESS (FOOTING) UP166I CHEST PREEES (IN GROUND) UP166S CHEST PRESS (SURFACE)

Parts List				
DESCRIPTION	UP166F (FOOTING)	UP166I (IN-GROUND)	UP166S (SURFACE)	PART NUMBER
CHEST PRESS	1	1	1	206456
BASE COVER	1	1	1	206699
FOOTBUCK WELD ASSEMBLY	0	1	0	206467
<b>HARDWARE COMPLETE</b>	0	0	1	206517
<b>HARDWARE COMPLETE</b>	1	0	0	206518
<b>HARDWARE COMPLETE</b>	0	1	0	206519
1/2" ANCHOR ROD	0	2	0	135038*
3/4" x 2" HEX HEAD CAP SCREW	0	4	0	801533*
3/4" WEDGE ANCHOR	0	0	4	206358*
3/4" ANCHOR BOLT	4	0	0	800001*
3/4" HEX NUT	8	4	0	804058*
3/4" FLATWASHER (2" O.D.)	8	4	0	817420*
3/4" LOCKWASHER	4	4	4	817354*

*Unless Otherwise Specified, All Units of Measure are Each*

*\*Items listed below Hardware Complete line are included with Hardware Complete Number*

**Warning: During Installation, Hardware And Small Parts Are Choking Hazards For Young Children. Store Unused Parts Appropriately Until Assembly Is Completed. Once Assembly Is Completed, Remove Any Unused Parts From The Play Environment And Dispose/Save Them In A Secure Location. Any bolt end protruding more than two full threads beyond the face of the nut causes risk of clothing entanglement. Promptly cut-off flush, file smooth, and treat to prevent corrosion.**

**Note: Peen Tee-Nuts and Flatwashers to match radius of pipe after assembly is complete.**

**Note: Loctite (supplied by others) should be used on any non-patch hardware.**

**BACKREST:** The Backrest shall be constructed from injection molded Nylon W6.

**BASE COVER:** The Base Cover shall be constructed from aluminum and powder coated.

**HANDLE GRIP:** The Handle Grip shall be constructed from injection molded PVC.

**INSTRUCTIONS:** The Instructions shall be constructed from aluminum produced by silk-screen printing.

**MAIN PIPE:** The main frame shall be an all welded assembly fabricated from SPP (carbon steel pipe) and dual phase steel plate. The frame shall be powder coated.

**MODULE CASE:** The Module Case shall be constructed from stainless steel and powder coated.

**PIPE CAP:** The Pipe Cap shall be constructed from injection molded Nylon W6.

**POST CAP:** The Post Cap shall be constructed from injection molded Polyethylene.

**SADDLE:** The Saddle shall be constructed from injection molded Nylon W6.

**HARDWARE:** All nuts, bolts, screws, and lock washers used in the assembly shall be stainless steel, yellow dichromate plated steel, blue-coat plated steel, mechanically galvanized or powder coated/yellow dichromate plated steel. All primary fasteners shall be 304 alloy stainless steel. Fasteners with yellow dichromate treatment have an electro-deposited, 99.9% pure zinc substrate applied from a specially formulated solution sealed with a yellow dichromate top coat designed to work in conjunction with the zinc plating.

## UP166F CHEST PRESS (FOOTING) UP166I CHEST PRESS (IN GROUND) UP166S CHEST PRESS (SURFACE)

**NOTE:** Do not overtighten bolts. To overtighten may cause buckling or dimpling of some parts.

**NOTE:** Read installation instructions thoroughly before starting assembly. Pour concrete only after final assembly is completed. Bracing material is required during assembly.

**NOTE:** Assembly and leveling times will be greatly reduced if a transit is used to set location and depth of ground holes.

### **INSTALLATION INSTRUCTIONS FOR UP166F (FOOTING):**

1. Attach Handle Ass'y to Main Post Ass'y using Square Bar and Main Shaft Ass'y, Spacer, Square Washer, M12 Large Washer, M12 Cap Washer, M12 Washer, M12 Lock Washer, M12 Nylon Nut, M12 Nut Cap. See Handle Ass'y Detail.
2. Dig holes or drill holes according to Plan View and Elevation View. **NOTE:** Due to extremes in weather and soil conditions, hole size may have to be increased to meet local conditions.
3. Fill hole with concrete. While the concrete is still soft, yet firm enough to support the Chest Press, Place (4) Anchor Bolts of the Chest Press in position. See Footing Detail. **NOTE:** Use Chest Press as a template for Anchor Bolt location, then remove Chest Press.

**IMPORTANT:** DO NOT MOUNT THE CHEST PRESS TO THE ANCHOR BOLTS FOR AT LEAST 7 DAYS.

4. After concrete has cured and set for a minimum of 7 Days, attach Chest Press to 3/4" Anchor Bolt using 3/4" Flat Washer (2" O.D.), 3/4" Lock Washer, and 3/4" Hex Nut. See Footing Assembly Detail.
5. Attach Base Cover to Equipment Post using Base Cover Nut and Base Cover Bolt included with Base Cover. See Base Cover Detail.

### **INSTALLATION INSTRUCTIONS FOR UP166I (IN-GROUND):**

1. Attach Handle Ass'y to Main Post Ass'y using Square Bar and Main Shaft Ass'y, Spacer, Square Washer, M12 Large Washer, M12 Cap Washer, M12 Washer, M12 Lock Washer, M12 Nylon Nut, M12 Nut Cap. See Handle Ass'y Detail.
2. Dig holes or drill holes according to Plan View and Elevation View. **NOTE:** Due to extremes in weather and soil conditions, hole size may have to be increased to meet local conditions.
3. Attach the Footbuck Weld Assembly to the Chest Press using 3/4" Hex Nut, 3/4" Lockwasher, 3/4" Flatwasher (2" O.D.), 3/4" x 2" Hex Head Cap Screw. See In-Ground Assembly Detail.
4. Place Chest Press into hole making sure it rests on the brick. See In-Ground Detail.
5. Level Chest Press using sway bracing.
6. Pour concrete according to the Plan View and Elevation View. Allow concrete to cure for a minimum of 7 days.
7. Attach Base Cover to Equipment Post using Base Cover Detail. See Base Cover Detail.

---

*UP166F CHEST PRESS (FOOTING)  
UP166I CHEST PRESS (IN GROUND)  
UP166S CHEST PRESS (SURFACE)*

**INSTALLATION INSTRUCTIONS FOR UP166S (SURFACE):**

1. Attach Handle Ass'y to Main Post Ass'y using Square Bar and Main Shaft Ass'y, Spacer, Square Washer, M12 Large Washer, M12 Cap Washer, M12 Washer, M12 Lock Washer, M12 Nylon Nut, M12 Nut Cap. See Handle Ass'y Detail.
2. Mark correct location of holes for Wedge Anchor using the Base Plate as a guide.
3. Drill 3/4" x 2 1/2" hole in concrete for Wedge Anchor. See Surface Detail.
4. Insert Wedge Anchors and secure with 3/4" Flatwasher (2" O.D.), 3/4" Lockwasher, and 3/4" Hex Nut. See Surface Assembly Detail.
5. Attach Base Cover to Equipment Post using Base Cover Detail. See Base Cover Detail.

**MAINTENANCE PROCEDURE:**

Periodically check hardware for tightness, and tighten as necessary. Always check all parts for breakage or wear, and immediately put equipment out of service until any faulty parts found are repaired or replaced. Also Check all metal parts for rust, paint loss and touch-up if necessary with paint. Check for welded areas and verify integrity. Check periodically resilient surfacing for appropriate depth and remove extraneous materials that could cause injury, infection, or disease. Maintain detailed installation, inspection, maintenance, and repair records for each public-use playground equipment.

UP166F CHEST PRESS (FOOTING)  
UP166I CHEST PRESS (IN GROUND)  
UP166S CHEST PRESS (SURFACE)

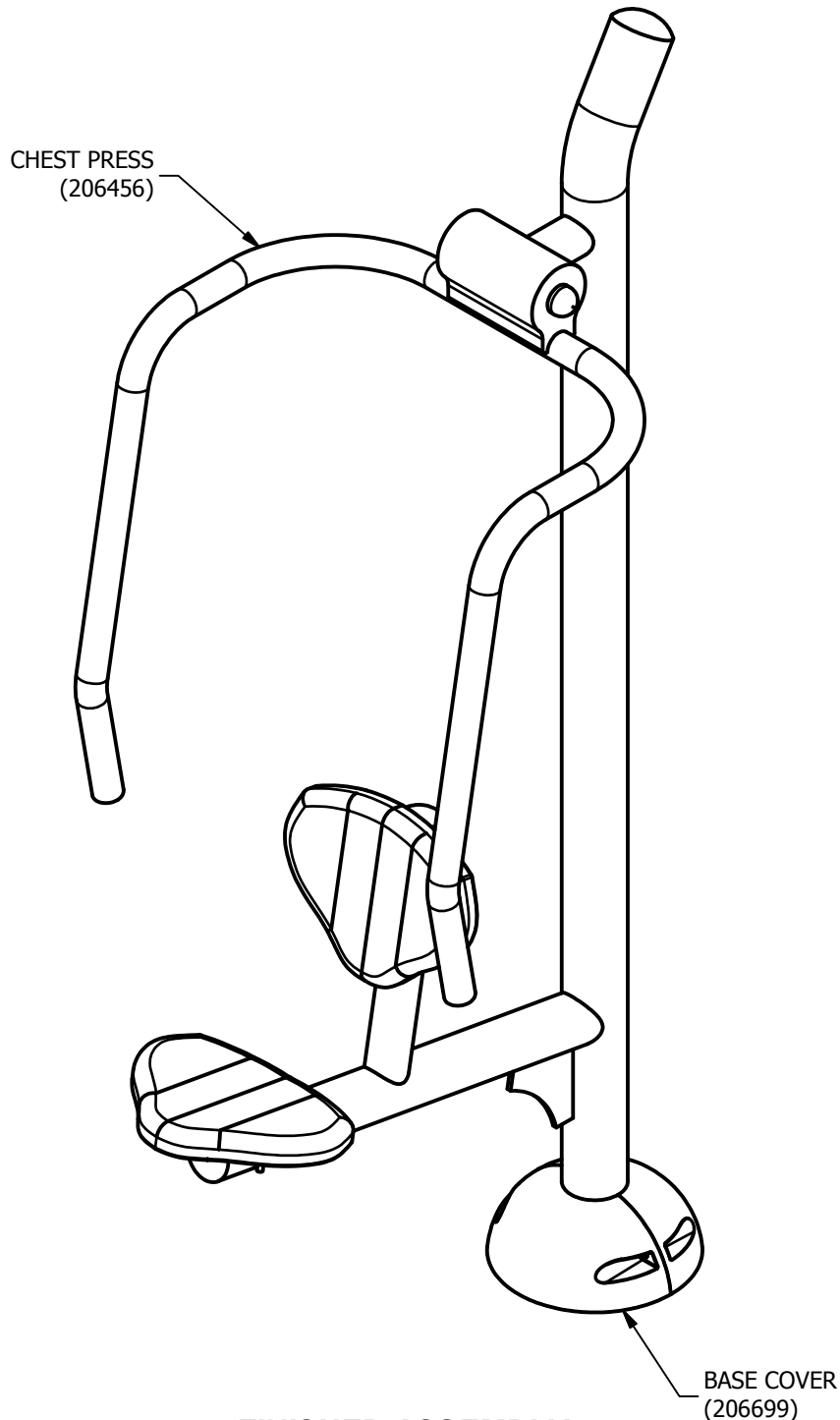

**FINISHED ASSEMBLY**

**UP166F CHEST PRESS (FOOTING)**  
**UP166I CHEST PRESS (IN GROUND)**  
**UP166S CHEST PRESS (SURFACE)**

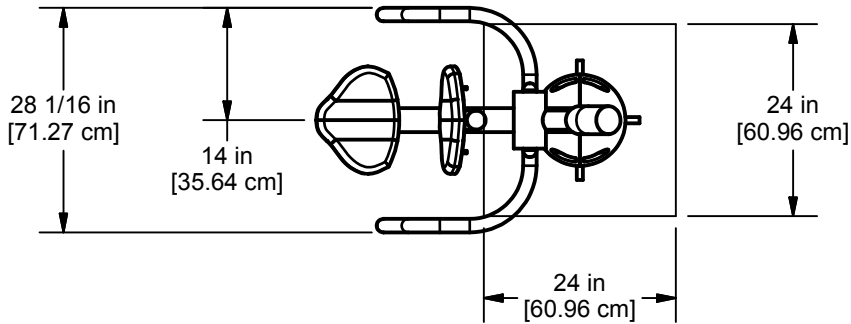

**PLAN VIEW**

**UP166F (FOOTING)**

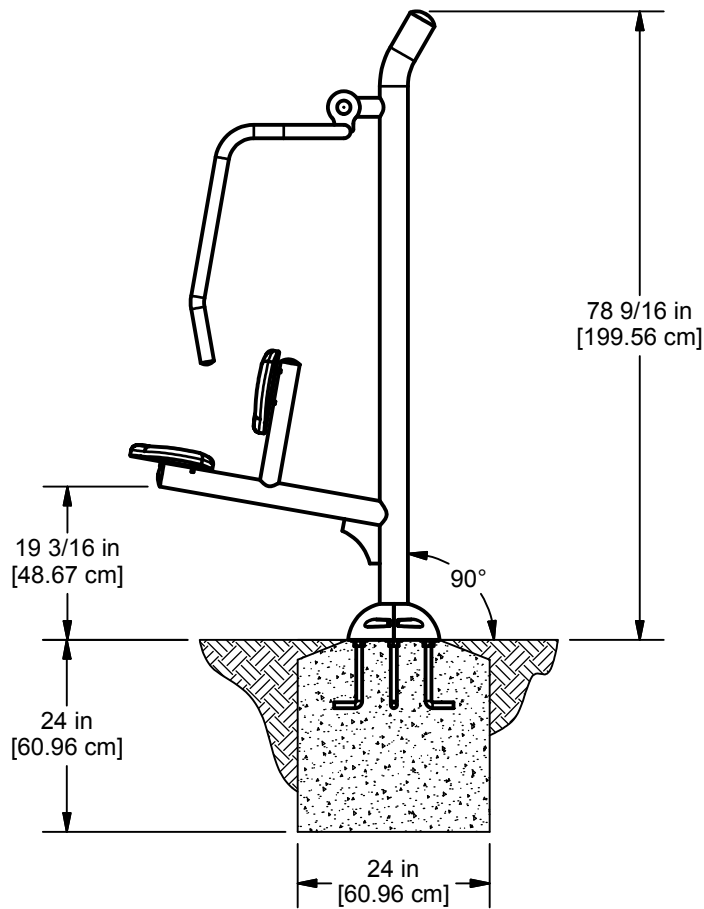

**ELEVATION VIEW**

**UP166F (FOOTING)**

Issued/Revised: 08/29/13



**UP166F CHEST PRESS (FOOTING)  
UP166I CHEST PRESS (IN GROUND)  
UP166S CHEST PRESS (SURFACE)**

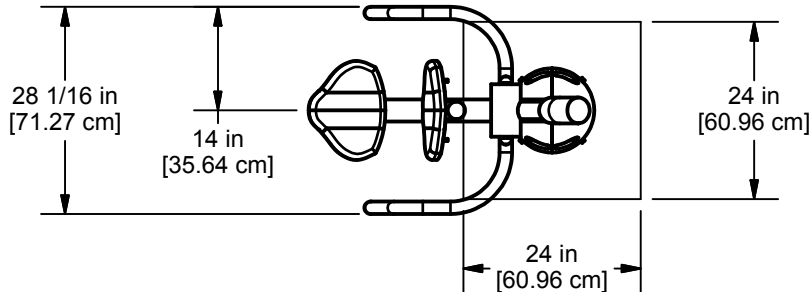

**PLAN VIEW**

**UP166I (IN GROUND)**

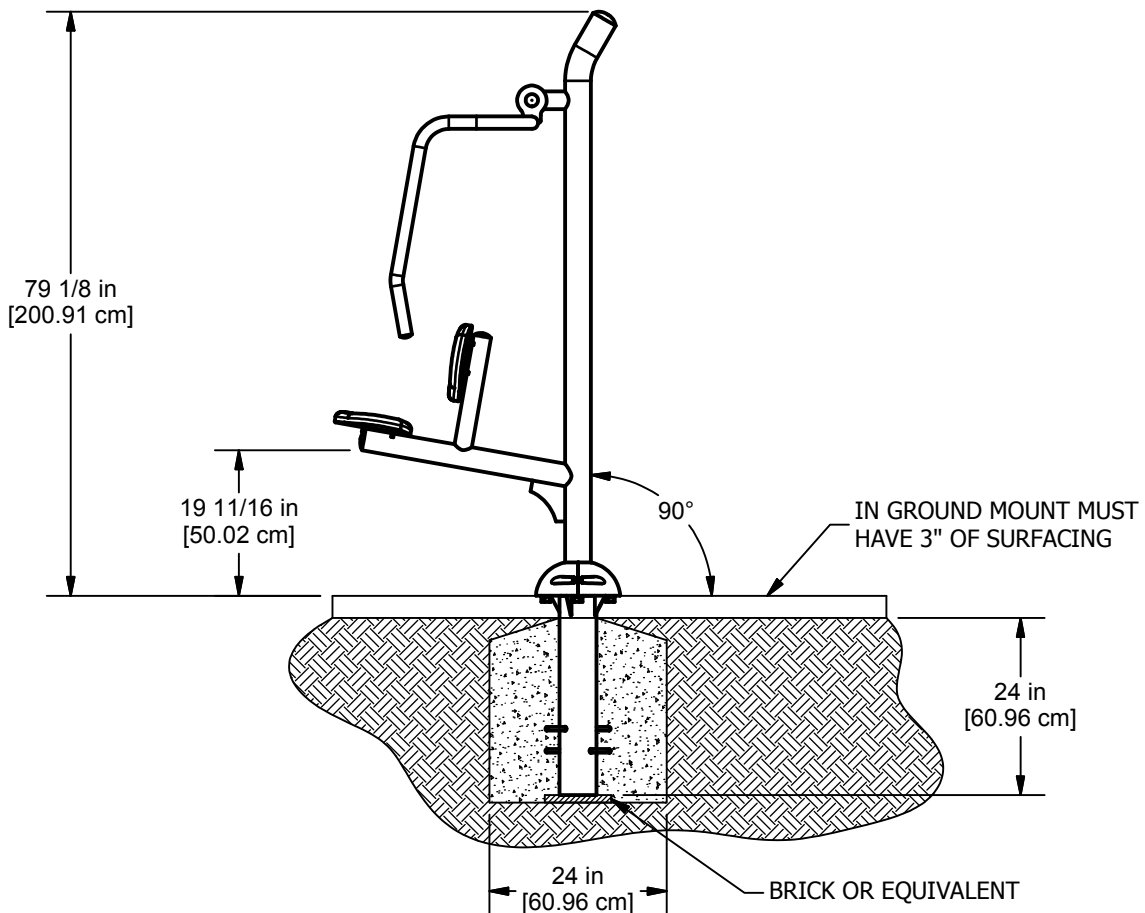

**ELEVATION VIEW**

**UP166I (IN GROUND)**

Issued/Revised: 08/29/13



A PLAYCORE Company

**UP166F CHEST PRESS (FOOTING)  
UP166I CHEST PRESS (IN GROUND)  
UP166S CHEST PRESS (SURFACE)**

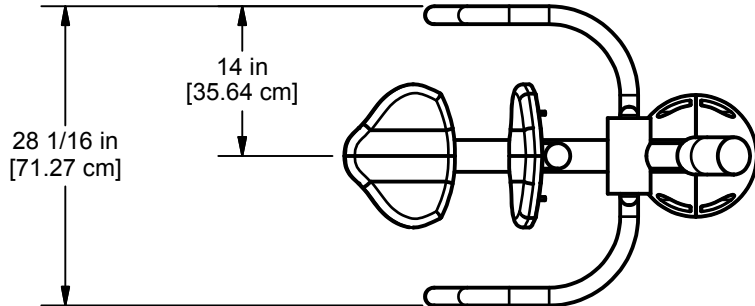

**PLAN VIEW**  
**166S (SURFACE)**

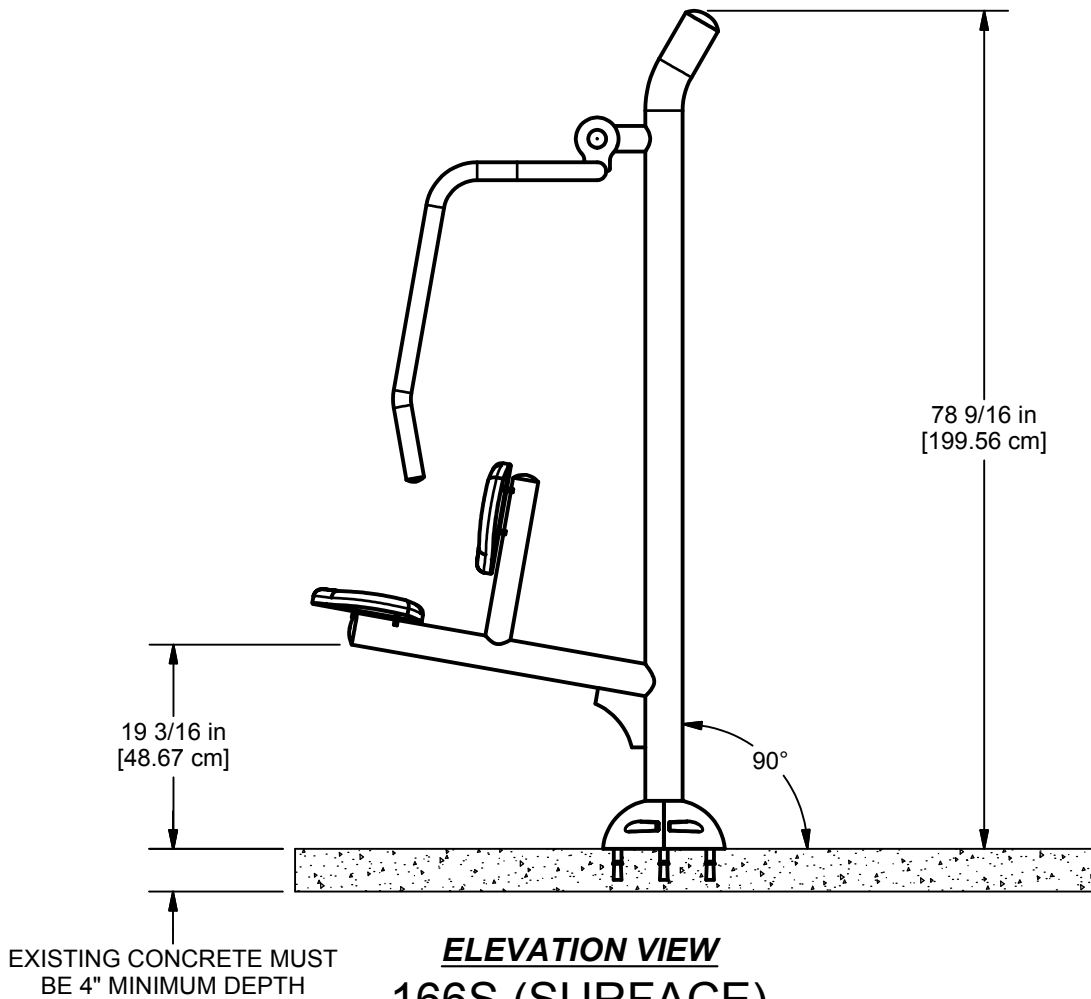

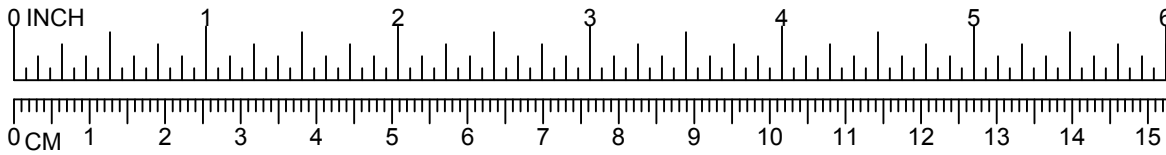

**UP166F CHEST PRESS (FOOTING)  
 UP166I CHEST PRESS (IN GROUND)  
 UP166S CHEST PRESS (SURFACE)**

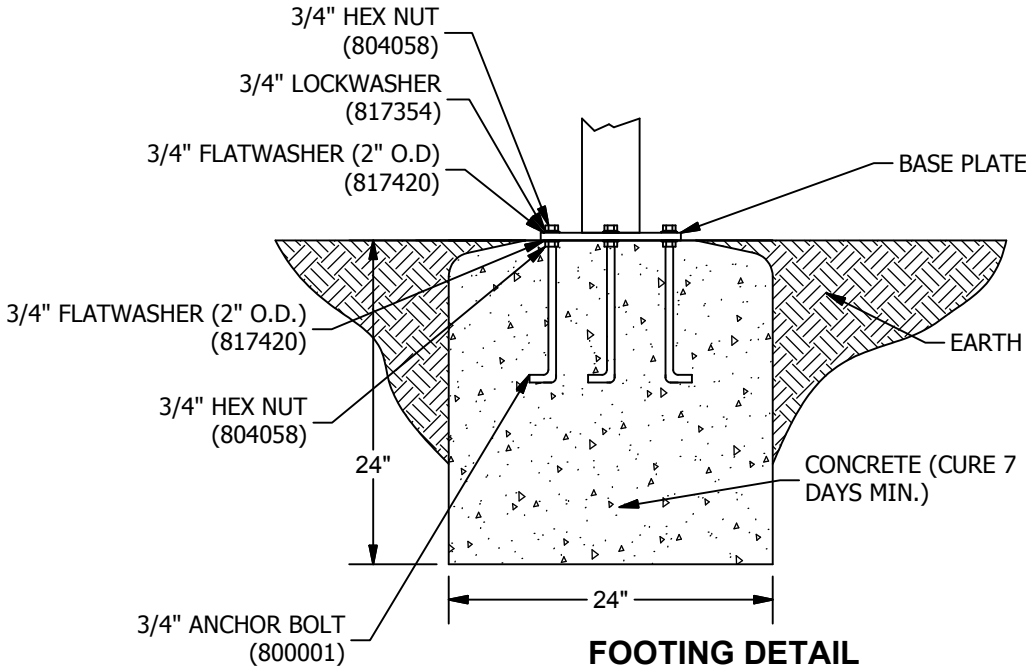

**CONCRETE REQUIRED:**  
 .23 CUBIC YARDS  
 .18 CUBIC METERS

**NOTE:**  
 -SLOPED FOOTING IS A REQUIREMENT OF EUROPEAN STANDARD EN1176-1 ONLY.  
 -SUGGESTED MINIMUM CONCRETE RATING 3000 PSI

**FOOTING DETAIL  
 UP166F (FOOTING)**

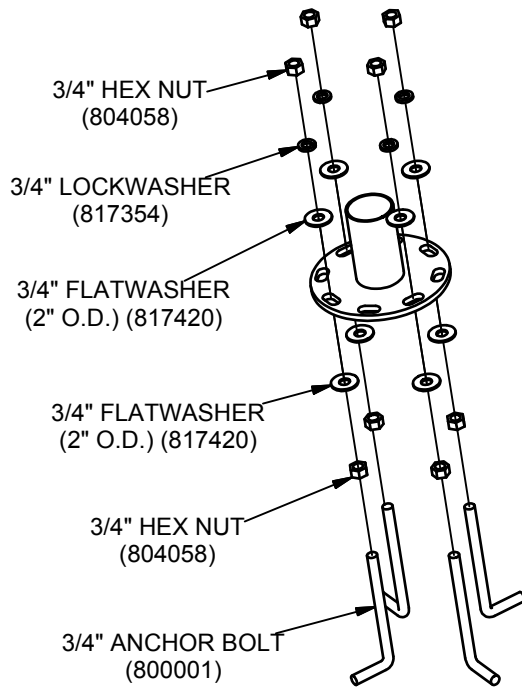

**FOOTING ASSEMBLY DETAIL  
 UP166F (FOOTING)**

Issued/Revised: 08/29/13





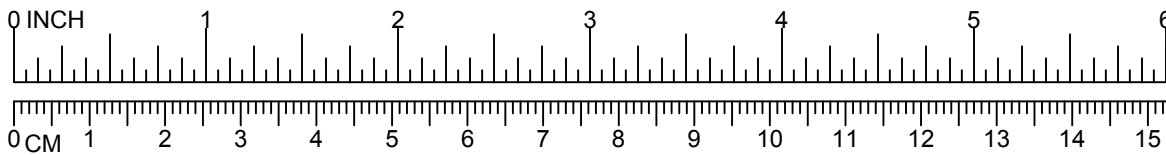

**UP166F CHEST PRESS (FOOTING)  
 UP166I CHEST PRESS (IN GROUND)  
 UP166S CHEST PRESS (SURFACE)**

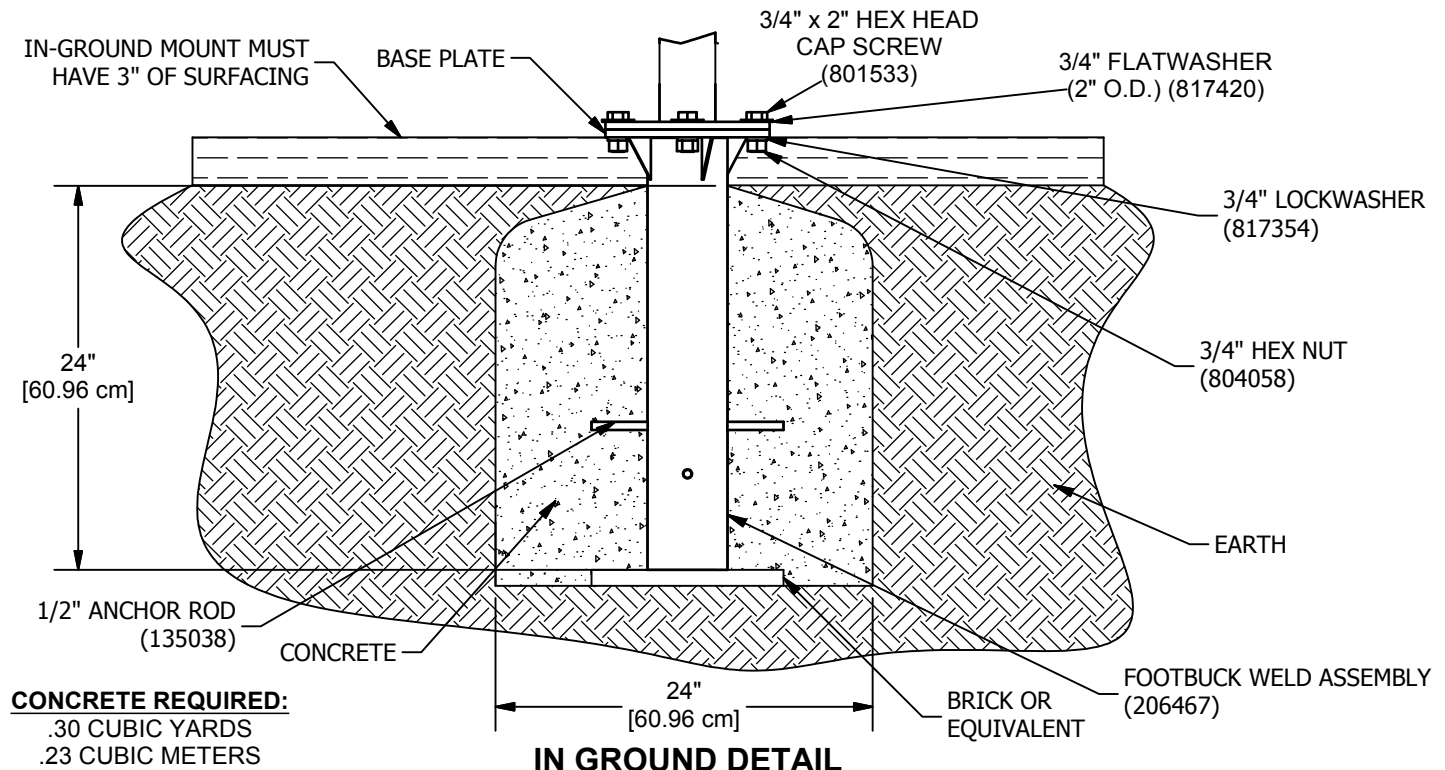

**NOTE:**  
 -SLOPED FOOTING IS A REQUIREMENT OF EUROPEAN STANDARD EN1176-1 ONLY.  
 -SUGGESTED MINIMUM CONCRETE RATING 3000 PSI.

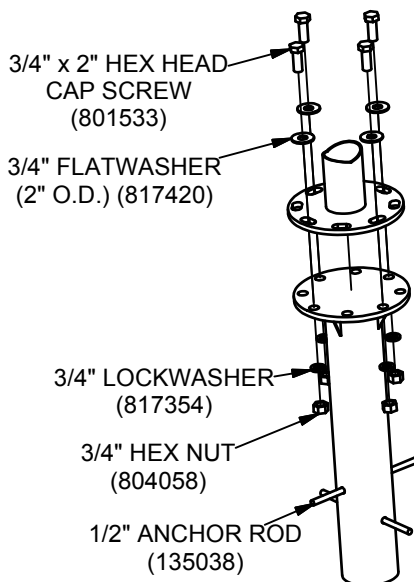

**IN GROUND ASSEMBLY DETAIL  
 UP166I (IN GROUND)**

Issued/Revised: 08/29/13



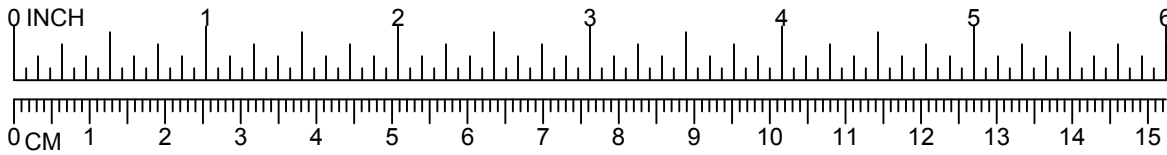

**UP166F CHEST PRESS (FOOTING)  
 UP166I CHEST PRESS (IN GROUND)  
 UP166S CHEST PRESS (SURFACE)**

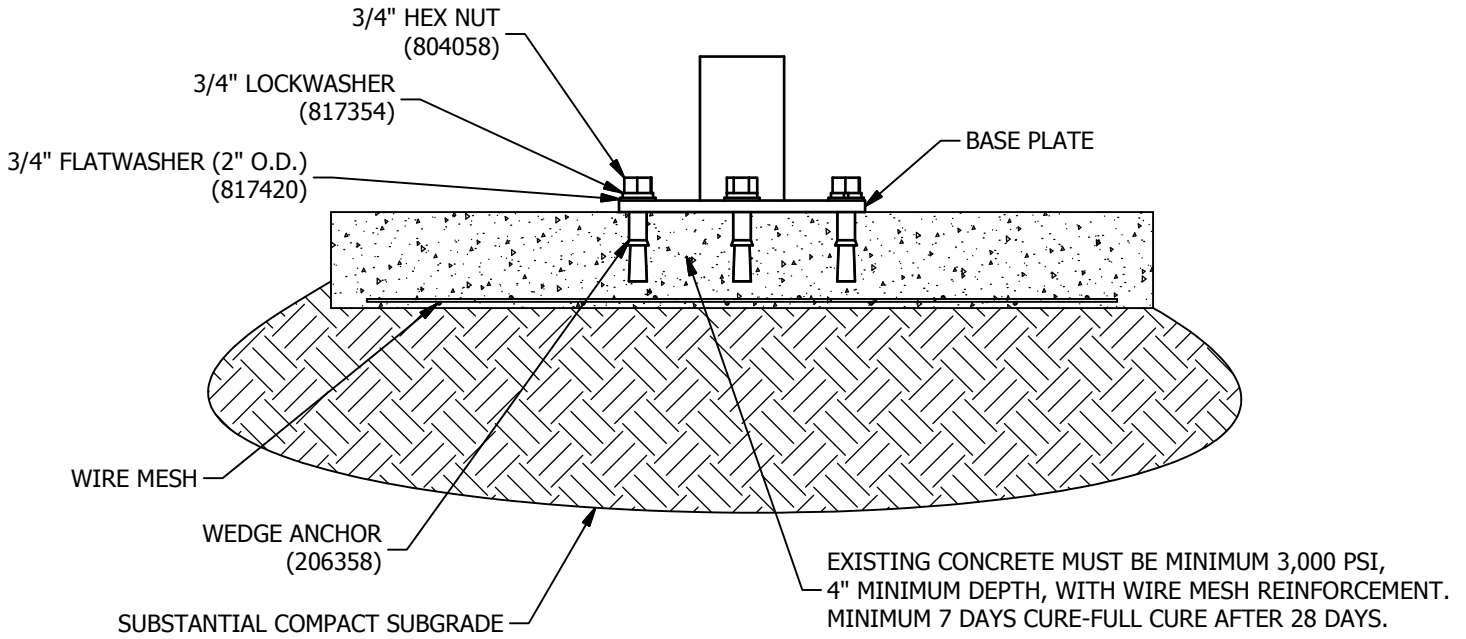

**SURFACE DETAIL**

**UP166S (SURFACE)**

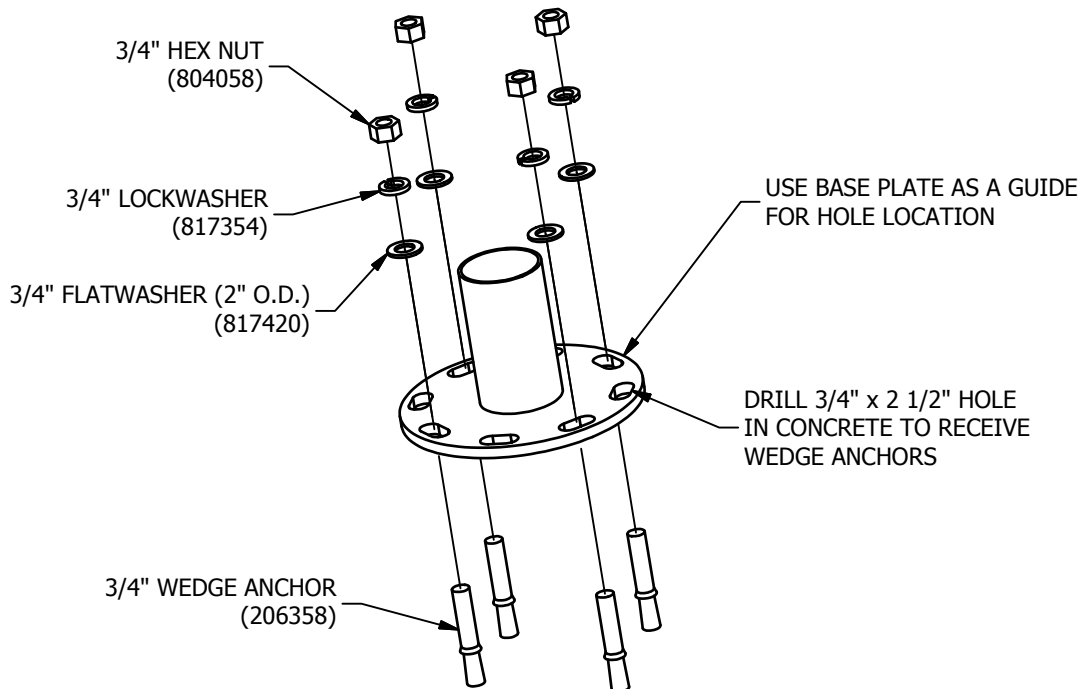

**SURFACE ASSEMBLY DETAIL**

**UP166S (SURFACE)**

Issued/Revised: 08/29/13



A PLAYCORE Company

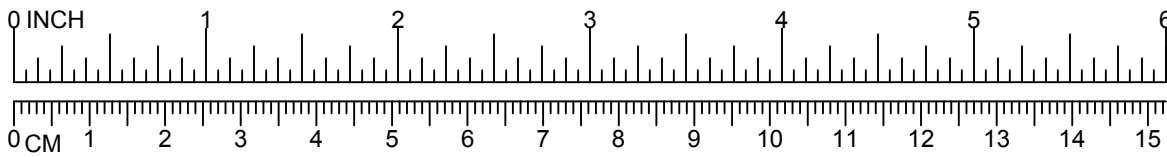

**UP166F CHEST PRESS (FOOTING)  
UP166I CHEST PRESS (IN GROUND)  
UP166S CHEST PRESS (SURFACE)**

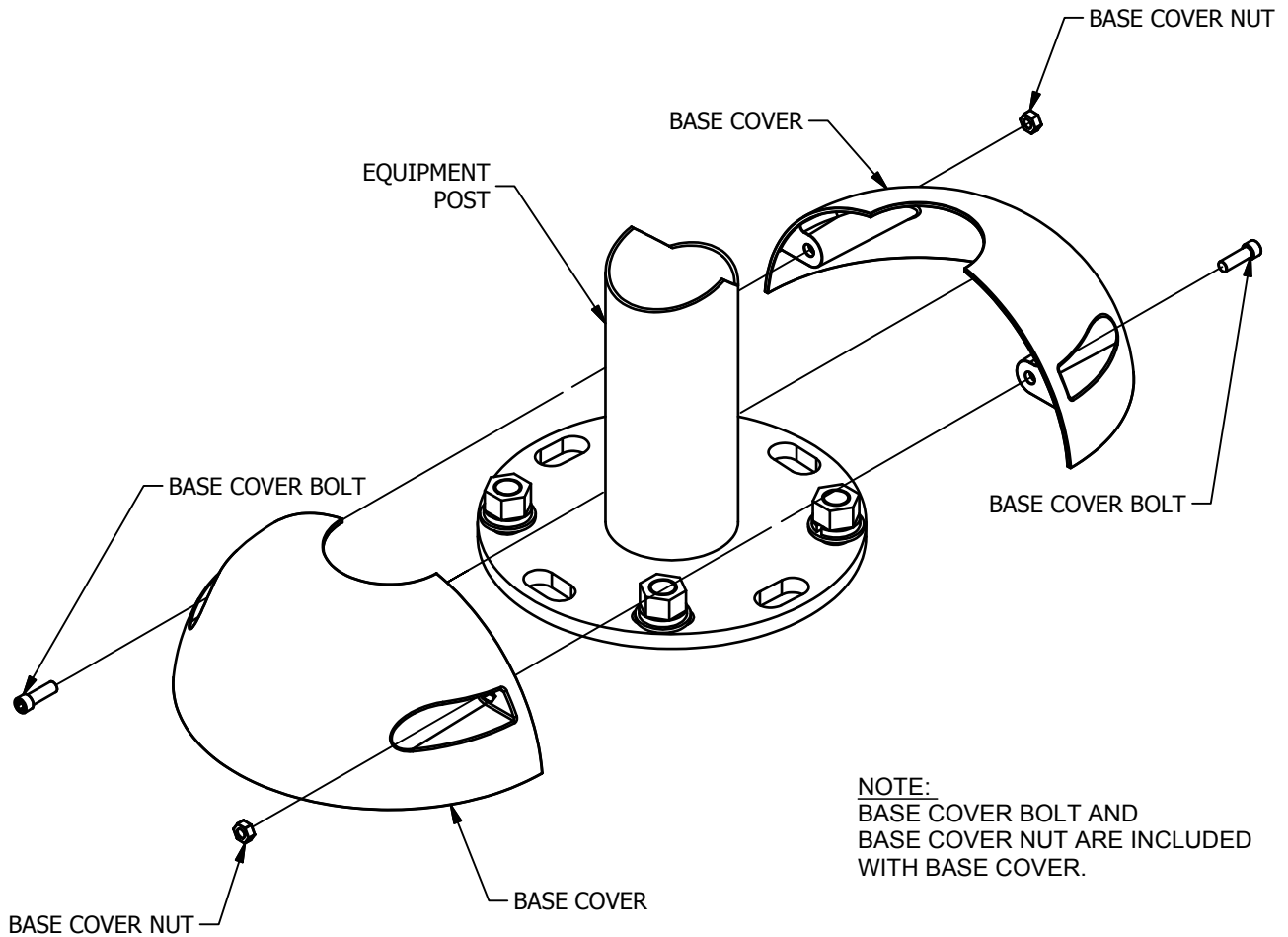

NOTE:  
BASE COVER BOLT AND  
BASE COVER NUT ARE INCLUDED  
WITH BASE COVER.

**BASE COVER DETAIL**

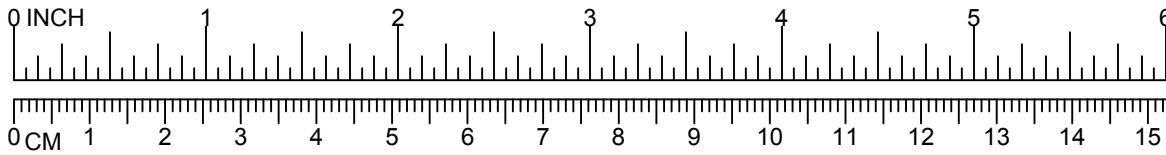

**UP166F CHEST PRESS (FOOTING)**  
**UP166I CHEST PRESS (IN GROUND)**  
**UP166S CHEST PRESS (SURFACE)**

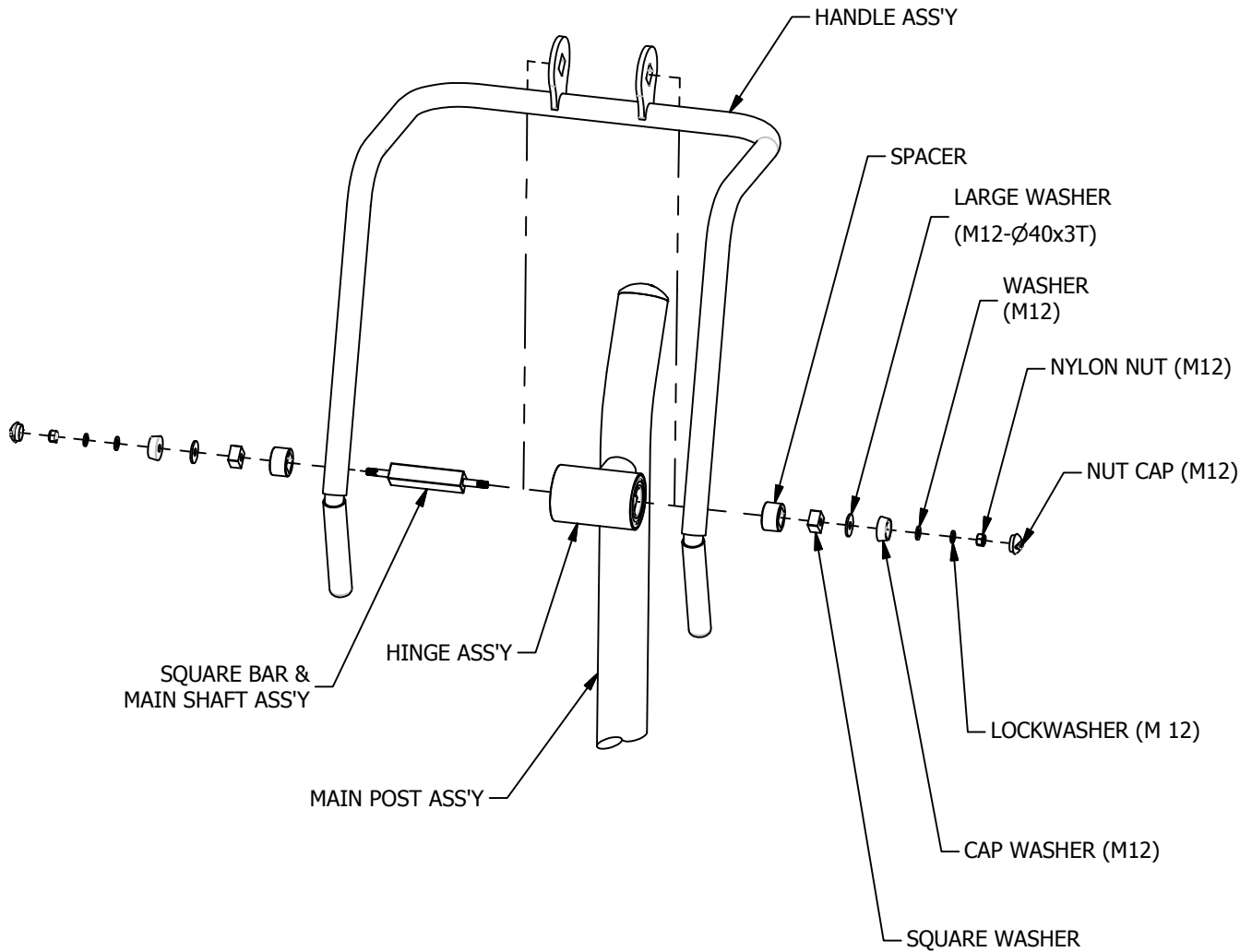

**HANDLE ASS'Y DETAIL**