



MAREY[®]

HEATER CORP.

**POWER GAS WATER HEATER
INSTRUCTION MANUAL**



GAS MODEL

Keep this manual with you after your unit has been installed,
you may need it for further technical information.





Congratulations!

You've just purchased a new Marey Power Gas tankless water heater and will soon begin to enjoy the benefits of "going tankless."

The availability of instant hot water, combined with the unit's outstanding energy efficiency and space saving design, will quickly convince you that you've made the best decision for meeting your home's hot water needs.

Take the time to thoroughly read and understand this safety and installation manual in its entirety before you attempt to install your new Power Gas tankless water heater, as it contains important safety tips and instructions.

Please carefully read all instructions and warnings. Should you have any questions, please visit www.marey.com for installation videos and FAQ. Please keep this manual for future reference.

WARNING: If you are not familiar with basic plumbing and electricity, we highly recommend that you employ the services of a professional to assist you with this installation. Under no circumstances should you attempt to install, repair, or disassemble the Marey Power Gas water heater without first shutting off any gas supplied to the unit.



INDEX

WARNING.....	05
INTRODUCTION.....	05
IMPORTANT SAFETY INSTRUCTIONS.....	06
SAFETY WARNINGS.....	06
DESCRIPTION OF OPERATION.....	08
OPERATING INSTRUCTIONS.....	09
EXTENDED SHUTDOWNS.....	15
COLD WEATHER WARNINGS.....	17
MAINTENANCE AND INSPECTION.....	19
TROUBLESHOOTING.....	22
DIAGNOSTIC CODES.....	26
INSTALLATION GUIDELINES.....	30
PACKING LIST.....	31
LOCATION AND CLEARANCE REQUIREMENTS.....	32
MOUNTING.....	33
ELECTRICAL.....	35
GAS PIPING.....	37
WATER PIPING.....	38
RELIEF VALVE.....	38
AIR INTAKE AND EXHAUST (VENT) SYSTEM.....	39
INTAKE AND VENT PIPE INSTALLATION SPECIFICATIONS.....	39
EXHAUST VENT PIPE ASSEMBLY.....	41
TERMINATION DETAILS.....	43

ACCEPTABLE VENT PRODUCTS.....	45
START UP AND TESTING.....	45
INITIAL START UP.....	46
REFERENCE.....	47
SYSTEM SPECIFICATIONS.....	50
DIMENSIONS.....	51
NAMES OF MAJOR PARTS AND COMPONENTS.....	53
TEMPERATURE INCREASE CHART.....	53
CUSTOMER SERVICE.....	54
OTHER PRODUCTS.....	55



WARNING

WARNING: If the information in these instructions is not followed exactly, a fire or explosion may result causing property damage, personal injury or death. Do not store or use gasoline or other flammable vapors and liquids in the vicinity of this or any other appliance.

WHAT TO DO IF YOU SMELL GAS:

- Do not try to light any appliance.
- Do not touch any electrical switch; do not use any phone in your building.
- Immediately call your gas supplier from a neighbor's phone.
- Follow the gas supplier's instructions.
- If you cannot reach your gas supplier, call the fire department.
- Installation and service must be performed by a qualified installer, service agency or the gas supplier.
- Water heater for other than recreational vehicle installation only.

IMPORTANT WARNING! There is water contained in the coils of your water heater at all times. If your water heater is exposed to freezing temperatures, the water in the coils could freeze, causing a break in the heat exchanger of the unit, or the supply and return lines. This kind of damage will result in water running freely into the space where the water heater is located, with can cause flooding. If your water heater is installed in a geographic location that sees very low sustained temperatures, you **MUST** install a backflow preventer on your heater's vent pipe. This will ensure that cold air cannot fall down into the water heater and cause freezing damage. **DO NOT** install this water heater where it may be subjected to a freeze. If your water heater is in an area where freezing is a possibility, you must turn off the water to the heater and drain it of any water by using the valve stem at the bottom of the unit and disconnecting the warm water line. Leave the valve stem and the warm water line disconnected until you intend to use the water heater.



INTRODUCTION

Thank you for purchasing a GA16ETL Gas Tankless Water Heater. In order to ensure proper installation, safe operation, and long life, please carefully read these instructions. Installation should only be completed by licensed professionals. The use of professionals ensures the installation is in full compliance with all required building, plumbing and electrical codes.

KEEP THIS MANUAL for future reference. This booklet includes useful information about the product, maintenance requirements and the details of your product warranty.



IMPORTANT SAFETY INSTRUCTIONS

READ AND FOLLOW ALL INSTRUCTIONS.

When using this equipment, basic precautions should always be followed.

Safety Definitions



This symbol is the safety alert symbol which is used to alert you to potential hazards that can kill or hurt you and/or others.



Indicates an imminently hazardous situation which if not avoided will result in death or serious injury.



Indicates a potentially hazardous situation which if not avoided could result in death or serious injury.



Indicates a potentially hazardous situation which if not avoided could result in minor or moderate injury. It may also be used to alert against unsafe practices.



SAFETY WARNINGS



DO NOT use a fuel gas that is not listed on the nameplate as compatible with the water heater. Abnormal combustion or a deflagration may occur which can cause a serious accident.



DO NOT use the unit if the vent piping has been damaged or altered in any way including cracking, separation, rusting, melting, etc. Improper venting may cause a buildup of Carbon Monoxide (CO) which can cause brain damage or death.

- If the water heater needs to be installed, moved, or serviced only utilize licensed professionals. The use of professionals ensures all work is in full compliance with required building, plumbing and electrical codes.

- Keep the area around the appliance clear and free of flammable materials such as cloth, wood, aerosol cans, paper, gasoline, etc.

- When using hot water for a shower or bath always check the water temperature before entry to avoid being scalded. Obey local codes for the maximum water temperature setting allowed. Water temperatures over 125°F (52°C) can cause severe burns or death from scalds. Households with small children, disabled or elderly persons may require a setting of 120°F (49°C) or lower.

- This heater is designed only for the heating of water and should not be used for other applications or used to heat any other media.

- Never use a fuel gas that is not listed on the nameplate as compatible with the water heater. Abnormal combustion or a deflagration may occur which can cause a serious accident including damage to the heater.

- Do not use this appliance if any part has been under water. Consult a qualified service technician to inspect the appliance and make any required repairs prior to installation and operation.

- This water heater is designed for indoor mounting. Never mount it outdoors.

- This equipment should be installed in an area where water leakage from the unit or connections will not result in damage. The manufacturer is not responsible for any damages resulting from leaks.

- Only connect gas and water as instructed. Incorrect or reversed connections will cause equipment damage.

- Do not over tighten connections or equipment may be damaged.

- Do not install in areas that are subject to vibration.

- This equipment may not be operated without the vent pipe properly connected. The exhaust pipe must not terminate in an area where the exhausting vapor or collecting condensate could create a hazardous situation or cause property damage. Exhaust gases must be vented out of the building in compliance with all building codes.

- The exhaust piping is very hot during and for a period after use. Do not touch the pipe.

- Ensure that snow, ice or other debris does not block the inlet or exhaust pipes.

- Regular housekeeping should be done in areas around the heaters to prevent insect intrusion and possible equipment malfunction.

- The unit should be serviced on a routine basis to ensure optimum performance. Service needs will vary based on local water conditions including acidity, alkalinity, hardness, etc.

- Freezing temperatures will cause damage to the heater. Install in locations where freezing temperatures are not reached and follow procedures to drain the unit if it will be out of service for a period of time.

- A 120 V / 60 Hz power source should be used. Fire, electrical shock or damage to the water heater may occur if an incorrect power supply is used.

- This appliance is equipped with a three-prong grounded plug for increased protection against electrical shock. Ensure the plug is properly inserted into a clean, dry outlet that complies with all electrical codes. Only insert and remove the plug using the plug head and never use a wet hand to plug or unplug the power plug.

- Any alterations to the appliance will void the warranty.



DESCRIPTION OF OPERATION

- GA16ETL gas tankless water heaters provide an efficient reliable supply of hot water.

- The temperature can be adjusted between 95°F and 149°F (35°C - 65°C).

- Only a small amount of water and a low water pressure (15psi) are required for the unit. Unit requires 0.67 gpm (2.5 l/min) to enable the unit. Unit stays in operation until the flow drops below 0.53 gpm (2 l/min).

- The burner ignition is electronic. The unit has no pilot light and consumes no gas when the heater is not being used.

- Air is brought into the unit from outside, efficiently burned with the appropriate source of fuel and then exhausted externally.

- The unit's integrated control system constantly monitors the temperature of the water being produced and adjusts the burner accordingly to deliver a stable supply of hot water.

- The unit is highly flexible and provides hot water over a wide range of flow rates and incoming water temperatures across the capacity range of the unit.

- GA16ETL heaters include a digital functionality that allows owners to control hot water consumption and conserve water.

- Multiple protective functions are included such as no-load heating prevention, automatic shutdown in case of accidental flame out, automatic pressure relief, etc. to make the appliance both safe and reliable

- In the event of a disruption in operation, a failure code is displayed and an alarm sounds an alert.



OPERATING INSTRUCTIONS

Normal Operation

This section of the manual instructs an owner on routine operating procedures and assumes that the water heater has already been installed, tested, and approved for operation. Initial start up requirements is detailed in the "Installation" section of this manual.

Routine Start Up

Follow this procedure for a heater that has been out of service.

1. Ensure all drain plugs are installed in unit.
2. Ensure all hot water use points (faucets, etc) are closed.
3. Open the water inlet valve.
4. Open a hot water faucet to confirm water flow and then close the faucet.
5. Open the fuel gas valve.
6. Plug in the unit, The message "CL" will be displayed indicating "Cold" state.
7. Press the "ON/OFF" key to turn on the unit.
8. Set temperature (see "Temperature Control" section of this manual).

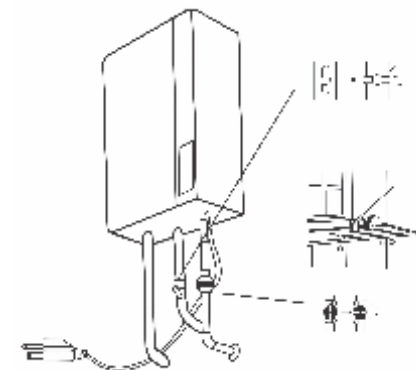

Control Panel

The Control Panel and display are used to adjust the operational settings of the unit as well as give information about the current state of operation. The following illustration shows all possible symbols and signs that may appear in various states of operation. In operation only the symbol or sign corresponding to the actual state will appear on the control panel display. The water heater is in an operating state when the hot water temperature is shown.

When the water temperature is above 95° F (35° C) the lamps are lit one by one from bottom to top.

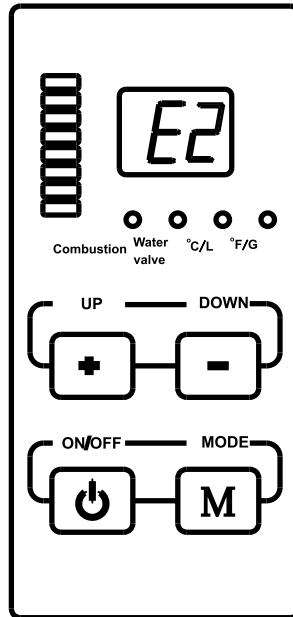

Failure mode displays when a failure occurs, temperature display mode is switched to failure display mode.

Switch between metric and English units: Press and hold the “+” and “-” keys at the same time for about 3 seconds.

Description of the mode key F3 current water quantity F4 preset water quantity

CONTROL PANEL INDICATIONS

LED display

1. Indicates the “Temperature Set Point” when blinking. Displays the “Actual Temperature” when the display remains lit.
2. It displays both the “Preset Water Quantity” and the “Actual Water Quantity”.

“**Combustion**” - When lit indicates that the water heater is operating and burning gas.

“Water valve” - Indicates one of the following three states:

1. No light indicates water heater is operating normally.
2. Blinking: Indicates there is no water flow through the water heater or the water flow is less than 0.66 gallons per minute (2.5 liters per minute)
3. When on and remaining lit, the firepower of the water heater is operating at either the minimum or maximum operating point. The actual water temperature may not reach the preset temperature. The water flow rate needs to be adjusted so the unit is operating within its capacity range. This will allow the desired temperature to be reached.

“°C/L” - Indicates metric units are being displayed (degrees Celsius, liters)

“°F/G” - Indicates English units are being displayed (degrees Fahrenheit, gallons)

“**Up + / Down**” keys - Used for setting the water temperature and water quantity.

“**Mode**” key - Used to Set (F4) the water quantity or Display (F3) the water volume already delivered.

“**ON /OFF**” key: This button enables or disables the water heater. In the “ON” mode, the temperature set point is displayed. The factory default temperature setting is 107°F (42°C). In the “OFF” mode, “CL” (Cold) is displayed.

TEMPERATURE CONTROL

Set the Desired Temperature

1. The temperature adjustment range is 95°F - 149°F (35°C – 65°C).
2. Press the “ON/ OFF” key. The temperature display unit lights up and displays the current temperature set point. The factory default set point is 107°F (42°C).
3. Press the “UP” or “DOWN” key to set any desired temperature between 95°F (35°C) and 122°F (50°C). The temperature set point goes up or down by one degree with each press.
4. To set a temperature above 122°F (50°C): Press and hold the “UP” key continuously for about 4 seconds until 131°F (55°C) is displayed.
5. **Note:** When the temperature is above 122°F (50°C), each press of the “UP (DOWN)” key causes the temperature to go up (down) by 9°F (5°C).

6. When the desired temperature is set above 122°F (50°C), the temperature display blinks for approximately 4 seconds before the display switches to show actual water temperature.

7. Along the left side of the temperature display, a series of bars indicates the level of the temperature set point. At each 9°F (5°C) increment, an additional bar lights. When the set point is above 122°F (50°C), the first red bar appears indicating the set point is in a zone where a scalding hazard exists.

8. The heater will retain the temperature set point unless there is a loss of power.

9. After the temperature is set, open the water valve and observe. The “Combustion” indicator should light indicating the unit is operating normally.

⚠ DANGER

SCALD PREVENTION

- Water temperatures over 125°F will scald and can instantly cause severe burns or death!

- Children, disabled and elderly are at highest risk of being scalded

- Always test the water temperature by feeling the water prior to entering a shower, bath, etc.

- Obey all codes regarding temperature set point. Contact a licensed plumber or local plumbing authority for clarification or additional information.



Set a Desired Volume

1. The volume display range is 0-250 gallons when system is set to use English units or 0-950 liters when in metric mode.

2. Press the “MODE” key briefly to display the message “F4”, then press the “UP” (or “DOWN”) key. The mode will switch from temperature display mode to water quantity display mode.

3. Displayed volume: Please note that the readout indicates the water quantity divided by ten (10). Example – if the display shows “10”, this correlates to a volume of 10x10 = 100 gallons (English unit mode) or 100 liters (metric unit mode).

4. Adjust the “Volume Set Point” by pressing the “UP” or “DOWN” key briefly. Each press corresponds to a change of 10 gallons of volume (English unit mode) or a change of 50 liter (metric mode).

Example 1: English unit mode: The digit 7 is currently being displayed. This indicates a set point of 70 gallons. Pressing the “UP” key once changes the set point to “8” indicating a water quantity of 8x10 = 80 gallons as the new set point.

Example 2: Metric unit mode: The digit 25 is displayed. This indicates a set point of 250 liters. Pressing the “UP” key once changes the display to “30” indicating a water quantity of 30x10 = 300 liters as the new set point.

5. When the water heater is discharging water to the bathtub and the volume set point is reached, the alarm on the remote controller will sound an alert for about 10 seconds.

Note: The output of hot water will not stop automatically.

⚠ CAUTION IMPORTANT! The volume measurement only keeps track of the water volume that passes through the water heater. For example, if hot water going to a tub is combined with cold water, the volume computed would not be representative of the total amount that may have filled the tub. This could lead to an overflow or damage!

Monitoring the Volume Delivered

Press the “MODE” key. The message “F3” will be displayed. Press the “UP” (or DOWN) key briefly. The mode will switch from temperature display mode to water quantity display mode. The water volume already delivered is displayed. Example: “5” = 5x10 (50L or 50G).

Power Outage

In the event of a power outage or if the unit is unplugged, settings are restored to their factory default values.

OPTIONAL WIRED REMOTE CONTROL PANEL (GA16ETL)

The heater may be controlled by a wired remote control (optional). The controller can be located near a bath, shower or other location. Figure - Wired Remote Control Panel

Remote Control Panel Indications

“Combustion” - When lit indicates that the water heater is operating and burning gas.

“Override” - When this indicator light is on. The wired control panel can change the temperature set point.



“°C/L” - Indicates metric units are being displayed (degrees Celsius, liters).

“°F/G” - Indicates English units are being displayed (degrees Fahrenheit, gallons)

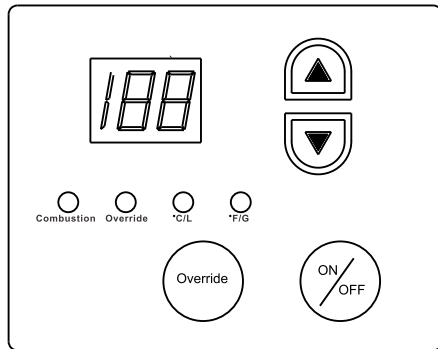
Remote Control Panel Functions (GASET)



- Remote shut down: If the water heater needs to be stopped when it is operating, press the “ON/ OFF” key. The displayed hot water temperature disappears. The water heater has stopped operating. The “Combustion” indicating light will go out. The water flow is not controlled by the remote. The water flow will continue until the faucet or shower is turned off.

Switch between metric and English units: Press and hold the  and  keys at the same time for about three seconds.

- Override (Priority) Control: Up to three remote control panels may be connected

to the system. At any given time, one of the control panels can become the “priority” controller. The priority controller becomes the master temperature control device for the system. To set priority:

Method A:

1. Turn off the override if it is set on another controller. Press the “Override” key to release priority. The Override indicator light will go out.
2. Select the new controller to take control. Press the “Override” key on the wired operation panel which should have priority. The “Override” indicator will turn on and the temperature set point may be adjusted from this controller.

Method B:

Another way to gain priority is to press the “ON/OFF” key twice on the units operation panel. The first press will shut the unit off, which will invalidate the Override ownership of the remote, and the second press will reactivate the unit which will reinstall factory defaults and set the unit’s panel the Override position, the “Override” indicator will turn on. When unit is in standby, the first wired controller to activate the unit will have priority and the Override indicator will turn on.

- Change the Temperature Set Point: First, enable “Override” or priority control for this remote control. Adjust the temperature using the “Up” and “Down” arrows.

- The temperature may be adjusted in one degree increments between 95°F (35°C) and 122°F (50°C).

EXTENDED SHUTDOWN

Extended Outage Procedure

If a heater will be out of service for an extended amount of time, use the following procedure to protect the unit.

NOTES

- Cold air may enter the unit through the air intake or the exhaust system. Take precaution for extended shutdowns even if unit is installed indoors in an area that does not allow direct exposure to freezing temperatures.

- Temperatures at or below 32°F (0°C) can cause permanent damage the unit and/or the piping system due to freezing.

- After a power outage, all settings return to their factory default values.

CAUTION

The heater and water within the unit may be very hot. Allow time for the system to cool and use caution when draining to minimize risk of injury.

1. Shut down the water heater by pressing the “ON/OFF” button. “CL” will appear indicating “Cold” state.

2. Close the fuel gas valve (1).

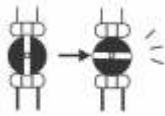

3. Unplug the power cord (3). Use dry hands. Exercise caution and only unplug by grasping the plug head and pulling. Note, all factory settings will be restored next time unit is re-powered.

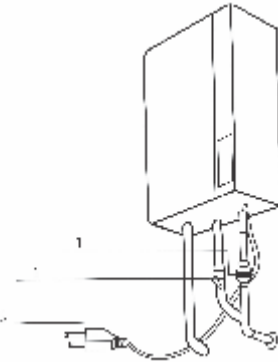

4. Close the water inlet valve. (4)

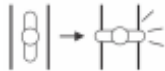

5. Open all hot water faucets.

6. Obtain an appropriate container to collect the residual water from the system.

WARNING

Prevent water from being discharged on the floor to avoid damage. Prevent water contact with any electrical source in the vicinity

7. Open the drain valve plugs and completely drain the water heater.

8. Continue draining to empty the whole hot water system.

Note: Freezing temperatures below 32°F (0°C) can cause permanent damage to the heater and/or the piping system.

9. Reinstall the drain valve plugs and close the hot water faucets.

10. To return a unit to operation, please refer to “Routine Start Up” found in the Operating Instructions section of this manual.

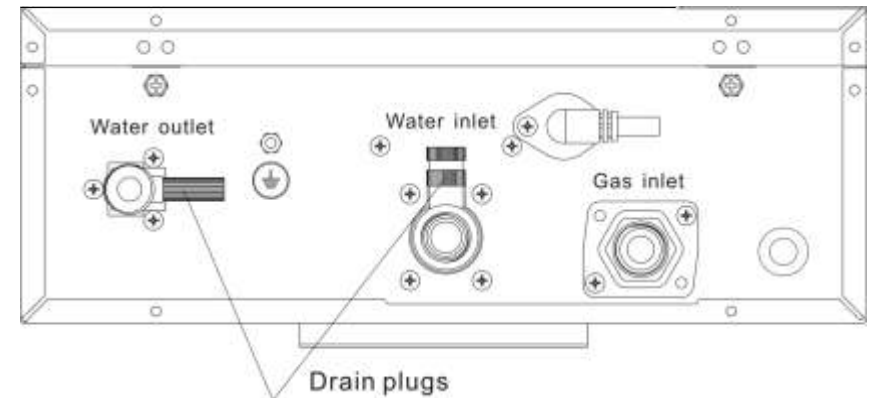

COLD WEATHER WARNINGS

Freezing Damage Potential and Precautions

Freezing temperatures can damage the water heater and/or water piping. Freezing water expands rapidly and can create tremendous mechanical forces. Mechanical damage and pipe ruptures can result from only brief exposure to freezing temperatures.

For best results, completely shut down the system by following the Extended Outage Procedure section of this manual.

In cold regions, insulating material or heat tracing can be used to protect pipes and fittings. Please consult your dealer if necessary.



Cold Weather with Potential Freezing Temperatures

Keep water flowing through the system to guard against freezing.

Follow these steps:

1. Close the fuel gas valve.
2. Turn off the power by pressing the “ON/OFF” button. “CL” will be displayed when off.
3. Open the hot water faucet at one or more points of use (sink, upstairs bathtub, etc.) Maintain a constant trickle. Monitor the stream of water to ensure it is still flowing.

No Flow Due to Expected Frozen Heater

1. Close both the fuel gas valve and the water inlet valve.
2. Turn off the power switch.
3. Open a hot water faucet.
4. Open the water inlet valve now and then to check for a water flow.
5. If no flow, attempt to thaw heater by using a portable heat source such as a hair dryer or portable electric heater.
6. Check occasionally to see if water flow has started.
7. When water flow resumes, carefully check for any signs of water leakage.
8. Resume normal operation.



WARNING To prevent damage, NEVER force a heater to operate while in a frozen state. NEVER bypass any safety feature.

Warranty

Damage caused by freezing is NOT covered by Warranty.

Routine Inspection



The heater and exhaust piping will be hot during and shortly after use. Use caution when working in the area around the heater.

To keep your water heater operating optimally please refer to the below recommended inspection and maintenance checklists. We recommend a periodic inspection performed by a qualified service technician. An annual inspection is normally sufficient. Frequent visual inspections by the owner are also recommended. Any repairs should be performed by a qualified service technician using only factory authorized components. Contact qualified technician for assistance.

Routine Inspection Checklist

- Any flammable materials in the vicinity of the water heater or exhaust piping?
- Any unusual noises coming from the heater while in operation?
- Are the air intake and exhaust free from any blockage or foreign objects?
- Any signs of water leaking near heater or pipes?
- Any abnormal appearance to unit casing?
- Any Discharge from Relief Valve?

Maintenance Checklist

- Clean outside of unit and control panel.
 - Use a wet cloth to remove any surface dirt. Use a dry cloth to wipe it dry.
 - A very mild detergent may be used if unit is very dirty.
 - Never use any petroleum based cleaners or solvents. These solvents can damage the panel.
- Check and clear Air Intake of any debris that might impede air flow.
- Clean inlet water screen.

- Examine venting system to insure system is clear of blockages, debris, and damage.
- Clean inside of unit by vacuuming or blowing out dust that collects in the unit. The burner and heat exchange are sealed units and should not be opened.
- Visual flame inspection
- Lime scale cleaning (if required), see procedure in Maintenance Procedures that follow.

MAINTENANCE PROCEDURES

BURNER INSPECTION AND CLEANING

1. The burner must flame evenly over the entire surface of the burner head when operating correctly.
2. The flame should burn with a clear, blue, stable flame.
3. Presence of a yellow flame or of black deposits on the burner head indicates cleaning and/or burner replacement should occur. THIS MUST BE DONE BY A TRAINED SERVICE PROFESSIONAL ONLY.

BLOWER MOTOR MAINTENANCE

1. The Blower Motor is permanently lubricated and does not need periodic lubrication.
2. If Blower Motor fails it should only be replaced by trained service professionals only.

RELIEF VALVE DISCHARGE

If a relief valve discharges periodically, this may be due to thermal expansion in a closed water supply system. Contact the water supplier or local plumbing inspector on how to correct this situation. Do not plug the relief valve.

LIME SCALE CLEANING PROCEDURE

Materials required:

- Five gallon container .

- Four gallons of virgin food grade white vinegar or virgin food grade citric acid.
- Small inline recirculation pump capable of circulating 2 - 4 gpm (8 – 16 l/m).
- Set of hoses for connecting recirculation pump to and from the pump and the five gallon container.

Refer to the figure on following page while performing this procedure.

1. Disconnect electrical power to the water heater.
2. Close the shutoff valves V3 and V4 on both the hot water and cold water lines.
3. Connect a hose H1 from the pump outlet to the cold water line V2 into the heater.
4. Connect drain hose H2 from the hot water outlet line V1 and route into five gallon recirculation container.
5. Pour approx. four (4) gallons of virgin, food grade, white vinegar or citric acid into pail.
6. Place the pump suction hose H2 into the cleaning solution

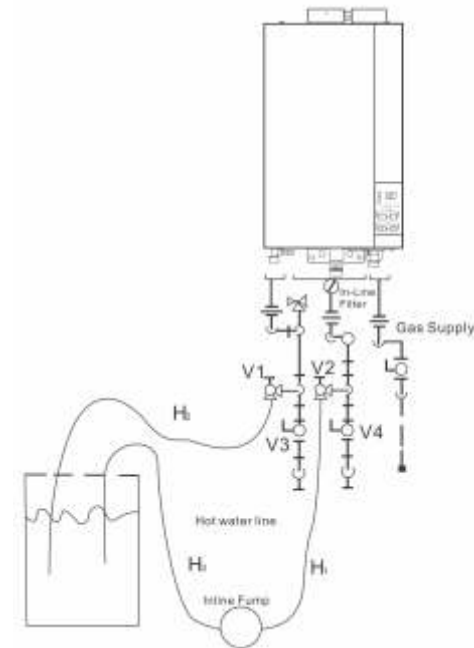

7. Open valves V1 and V2 into the water heater.

8. Operate the pump. Circulate the cleaning solution through the water heater for at least 45 minutes.

9. Turn off the pump.

10. Rinse the cleaning solution from the water heater by closing valve V2 and opening valve V4, flow water through the heater and into a container or drain for at least five minutes.

11. Close Valve V1 and Open Valve V3 this places the house back online.

12. Disconnect all hoses.

13. It is also wise to clean the water inlet screen at this time. Close Valve V3 and V4 to do so. Clean the water inlet screen and remove any debris.

14. Replace the screen and open valves V3 and V4 once more. Checks for leaks.

15. Return heater to operation by following start up instructions.

ELECTRICAL MAINTENANCE WARNINGS



Label all wires prior to disconnection when serving controls. Wiring errors can cause improper and dangerous operation. Always verify proper operation after servicing.



TROUBLESHOOTING

For operating difficulties with your unit, please consult the following table for guidance. If you need further assistance, call qualified technician. Please have product information ready when you call including serial number, date of purchase and error code if shown on the control panel.

Note: Please check water heater for an error code and respond according to recommendations found in "Error Codes" portion of this manual.

Trouble	Possible Cause	Remedy
No "CL" displaying.	Power outage.	Unit requires 120V power. Use unit when power is restored. Check circuit breaker and reset if needed. Check ground fault circuit interrupter (GFCI) if circuit includes one and reset if necessary.
	Unit is unplugged.	Check power plug and ensure properly plugged. Plug the power plug properly.
There is no hot water flow when a hot water faucet is opened.	No/empty fuel source.	Fuel gas valve needs to be open.
	Water valve closed.	Refill source tank (if applicable). Open the water inlet valve.
	Power outage.	Unit requires 120V power to operate.
	Flow is too low or became too low. (less than 0.66 gallons per minute (gpm) or 2.5 liters per minute (l/m)).	Flow is below the lower limit necessary for stable burner operation and proper temperature control. Increase the hot water flow to enable system.
	Freezing temperatures may have frozen water in the heater or hot water system.	See "No Flow Due to Expected Frozen Heater" section of this manual for procedure to thaw unit.
	Fuel gas meter special control restrictions.	Some fuel gas valves may have special restrictions or digital controls that use. Consult your gas supplier and/or a service professional for assistance.
	Distance from heater to source is long.	Allow time for hot water to travel through system to reach the point of use.

Trouble	Possible Cause	Remedy
Hot water is not the right temperature (too hot or too cold).	Temperature set point was reset due to power outage.	Power outage restores default settings and custom set points must be re-entered to unit
	Temperature set point incorrect.	A remote wired controller is controlling temperature set point. Release override control of this remote (see “ Remote Control Panel Functions ”) or change set point to desired temperature with that remote.
	Flow is beyond capacity.	Desired water flow is above maximum capacity of unit. Reduce user flows to re-establish control of temperature
Incoming water is too warm.	Incoming water is too warm.	If incoming water to unit is very warm and the flow is just above minimum requirements, the heat generated by the burner while operating at minimum capacity can make the water hotter than desired. Increase the hot water user flow so that the burner system can control the temperature.
	Hot water flow produced is lower than expected.	Water source is restricted. Check and fully open water inlet valve(s) Check and clean inlet water filter
Hot water flow produced is lower than expected.	Heat exchanger in unit is scaled.	Clean heat exchanger by flushing per maintenance procedure.
	Incoming water temperature is colder than expected.	Colder than normal incoming supply water will reduce the amount of hot water than can be produced.

Trouble	Possible Cause	Remedy
		Although the amount of heat output from the unit is still at full capacity, you must reduce the user flow and operate within the capacity range of the heater.
The hot water coming appears white and turbid.	Small bubbles may appear when water is heated. Air dissolved in water may evolve when water is heated.	None. Normal operation.
Vent system trouble.	Vent system is restricted in some manner.	Check air intake and exhaust ducts to ensure they are not damaged, corroded, blocked, etc.
“Smoke” observed coming from exhaust system during cold temperatures.	Water vapor produced during combustion is condensed in the exhaust as the hot gas is cooled by the outside air.	None. Normal operation.
Water leaking from safety valve outlet.	Water system is operating above design pressure.	Consult professional for system review.
	Safety valve is damaged.	Replace safety valve. Consult professional as required.
Blower fan noise can be heard for some time after operation stops.	The blower is designed to run for 30 seconds after burner shuts off.	None. Normal operation.

Trouble	Possible Cause	Remedy
The volume alarm does not sound even though the volume appears to be adequate.	Units incorrect during input Measuring flow of only hot water instead of hot water and cold water combined	Refer to “ Set a Desired Volume ” section to ensure units (metric vs. English) and volume (displayed volume number represents 1/10th of the actual total flow) is correctly set. The volume measurement only keeps track of the water volume that passes through the water heater. If hot water going to a tub is combined with cold water, the volume computed would not be representative of the total amount that may have been dispensed.
Unresolved problem.	Other assistance required.	Consult qualified technician or contact an authorized service professional.



DIAGNOSTIC CODES

Whenever a failure occurs, an alert sounds and a diagnostic code is displayed to indicate the failure mode at the time of occurrence.

The following table includes a list of diagnostic codes that can be displayed as well as recommended remedies to address the problem.

Control Panel Example - Displaying Error Code E2

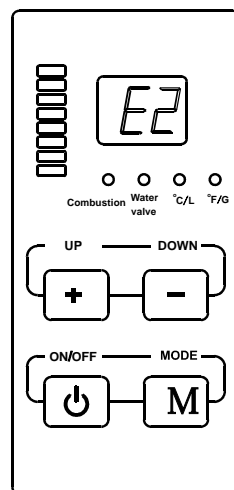

Code	Indication	Remedy
E0	Blower system problem occurred. 1. The blower jammed or stopped operating because of a foreign object. 2. The blower fan suffered a mechanical breakdown. 3. The fan power control module has broken down. 4. Wiring harness or wiring connection somewhere in fan connection has come loose.	1. Check to see if fan turns freely. Remove any foreign objects jamming the fan. 2. Replace the blower fan. 3. Replace the control module. 4. Reconnect as required.
E1	Outlet water temperature sensor error. 1. The sensor plug has come loose or failed to connect properly to the circuit board. 2. The sensor broke down (A short circuit, open circuit, or accidental contact with the casing occurred.) 3. The circuit board of the controller malfunctioned. 4. Sensor is scaled	1. Plug in the element properly. 2. Replace the temperature sensor. 3. Replace the controller 4. Clean sensor
E2	Flame detection error. 1. The detection circuitry for ignition and flame detection has come loose or failed to connect.	1. Connect the relevant circuit properly and eliminate the bad connection. Replace any failed circuit elements.

Code	Indication	Remedy
	<p>2. Ignition sequence was unsuccessful.</p> <p>3. An accidental flameout occurred.</p> <p>4. The ignition and flame detection circuitry malfunctioned or broke down. Igniter is not activating.</p> <p>5. Wrong gas type is used.</p>	<p>2. Check fuel gas supply (especially when first installed as air pockets might exist in the gas line. Retry the ignition process several times).</p> <p>3. Check if the fuel gas pressure is too high or too low</p> <p>4. Replace or repair igniter or flame detection system.</p> <p>5. Check the gas type, if the gas type that the building is supplied with is not the one indicated in rating plate on unit, contact the dealer for the proper unit to match the gas type</p>
E3	<p>Inlet water temperature sensor problem.</p> <p>Same possible causes described in Section E1.</p>	<p>Same troubleshooting methods described in E1.</p>
E4	<p>High temperature automatic shutdown.</p> <p>For ten (10) seconds a water temperature above 185°F (85°C) was detected. The controller has automatically closed the electromagnetic valve and unit shut down.</p>	<p>Normal safety precaution to protect against a rare occurrence in which unit is enabled and then the water flow is dramatically reduced causing a small slug of very hot water.</p>
E5	<p>Overheating occurred</p> <p>1. Overheating occurred. Possible causes include operating at a very high load for a long period and then there is a</p>	<p>1. Normal system function. This should be a very infrequent event. Correct gas or water supply issues if there are frequent reoccurrence.</p>

Code	Indication	Remedy
	<p>sudden event such as excessively low pressure in water supply or excessively high gas supply pressure.</p> <p>2. The temperature controller or the high temperature fusible protection wire has separated.</p>	<p>2. Replace the fusible protection wire.</p>
E6	<p>Solenoid valve error.</p> <p>1. The wiring is loose or a bad connection occurred.</p> <p>2. The solenoid valve is faulty.</p> <p>3. Controller has failed.</p>	<p>1. Mount plug-in wiring properly and replace bad elements.</p> <p>2. Replace solenoid valve.</p> <p>3. Repair or replace the controller.</p>
E8	<p>Exhaust system error.</p> <p>1. Wiring harness or wiring connection somewhere in air pressure switch connection has come loose.</p> <p>2. Exhaust (air intake) ducts is jammed.</p> <p>3. The pressure vent is jammed.</p> <p>4. The wind pressure switch is damaged.</p> <p>5. Too many elbows or too long vent pipes caused excessive exhausting resistance.</p>	<p>1. Plug the plug-in element in place, or replace the bad element.</p> <p>2. Replace and/or clean Exhaust (air intake) ducts.</p> <p>3. Replace and/or clean the vent.</p> <p>4. Replace the wind pressure switch.</p> <p>5. Choose proper location for terminal installation, and follow the instruction about Max Vent length to choose right number of elbows and length of total vent pipes.</p>



INSTALLATION GUIDELINES

Only properly qualified personnel should install this equipment. Improper installation or installation by a non-qualified installer may void warranty. Failure to comply with state and local codes pertaining to water heater installations may void also warranty.

GA16ETL water heaters are suitable for installation as a single standalone unit or in installations involving combinations of multiple units (i.e. parallel or series). These guidelines are for the installation of a single unit. Please contact authorized service center for multiple device connection assistance.

This appliance shall NOT be installed outdoors.

A qualified installer or service technician should inspect and leak test system before use.

The installation must comply with local codes. In the absence of local codes the National Fuel Gas Code, ANSI Z223.1/NFPA 54, or the Natural Gas and Propane Installation Code, CSAB149.1 shall prevail.

The appliance must be electrically grounded in accordance with local codes. In the event there are no local codes, the National Electrical Code, ANSI/NFPA 70, or the Canadian Electrical Code, CSA C22.1 shall prevail.

Maximum inlet gas pressure must not exceed the value specified by the manufacturer and that the minimum value listed is for purposes of input adjustment.

Disconnect the heater and the heater main gas valve from the gas supply piping system during any pressure testing. Isolate the heater from the gas supply piping system by closing the inlet manual shutoff valve. The gas pressure will be between these values 3.5 in W.C. (870 Pa) 10.5 in W.C. (2610 Pa) for Natural Gas and 8.0 in W.C. (1990 Pa) 13.0 in W.C. (3230 Pa) for Liquid Propane.

The appliance should be located in an area where water leakage of the unit or connections will not result in damage. Take precaution by properly installing a drain pan under the heater if required to protect area where leakage would travel.

Do not obstruct the combustion air intake or heater exhaust and ensure air intake is not near an area that will allow chemical fumes to enter the combustion air system.

Do not use to heat pools or spas (hot tubs) that uses chemically treated water.

If a water heater is installed in a closed water supply system, special precautions are required such as installation of a backflow preventer and allowance for thermal expansion. Consult an authorized professional for proper installation requirements.



PACKING LIST

The following contents are included. If any items are missing contact authorized after sales service.

Item	Item #	Quantity
Water Heater	A	1
Installation and Operation Manual	B	1
Expansion Bolts	C	5
Seal Ring	D	5
Self-tapping Screw	E	4
Expansion Anchors	F	4
Vent Adaptor (AL-0303A)	G	1
Vent Adaptor (AL-0303B)	H	2



A. Water Heater



B. Installation and Operation Manual



C. Expansion Bolts



D. Seal Ring



E. Self-tapping Screw



F. Expansion Anchors



G. Vent Adaptor (AL-0303A)



H. Vent Adaptor (AL-0303B)



LOCATION AND CLEARANCE REQUIREMENTS

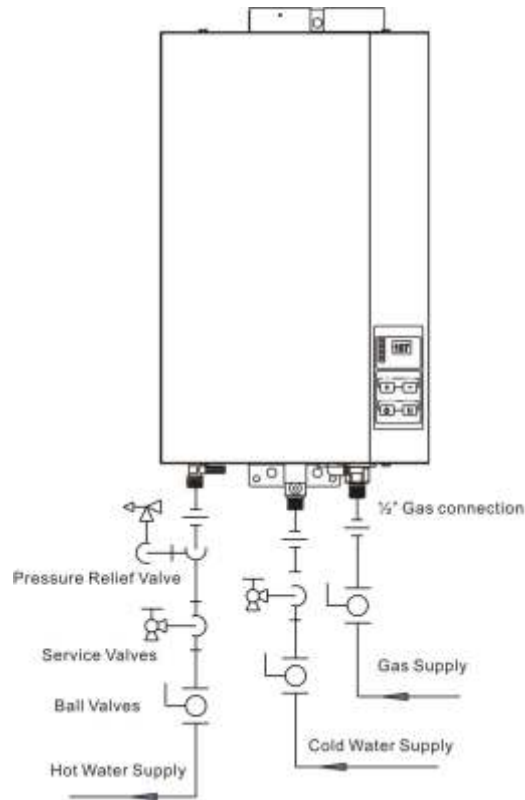

LOCATION

Choose a location for unit installation taking into account the following guidelines.

- Unit must be installed indoors. Installation is not recommended in bathrooms, bedrooms or occupied rooms that are normally kept closed.
- Unit should have proper clearance as indicated below including ample clearance in front of unit for proper service access.

Installation is recommended to be at a height that will allow easy viewing and operation of the control panel.

- Heater requires a standard three prong, 120 V /60 Hz grounded AC power outlet within 5 feet (1.6 meters) of installation location.
- Heater requires a 1/2" gas supply line (12mm).

- Ventilation requirements must be considered when choosing installation location.
- Minimizing vent piping will reduce installation costs and maximize efficiency. We recommend that a service valve kit be used for the installation as it will reduce installation costs and make servicing the water heater easier. The Webstone 44043PR or similar service valve kit. These kits include the Service Valves, Unions, Ball Valves and Temperature / Pressure relief valves specified in the Typical Installation Figure above in one convenient easy to install kit.

CLEARANCE REQUIREMENTS

ADJACENT MATERIAL COMPOSITION

NON-COMBUSTIBLE	COMBUSTIBLE
SIDE: 2 inches (50 mm)	2 inches (50 mm)
TOP: 2 inches (50 mm)	6 inches (300 mm)
FLOOR: 12 inches (300 mm)	12 inches (300 mm)
FRONT: 24 inches (600 mm)	24 inches (600 mm)
BACK: zero (zero)	1 inch (25 mm) fireproof

Insulating panel required.

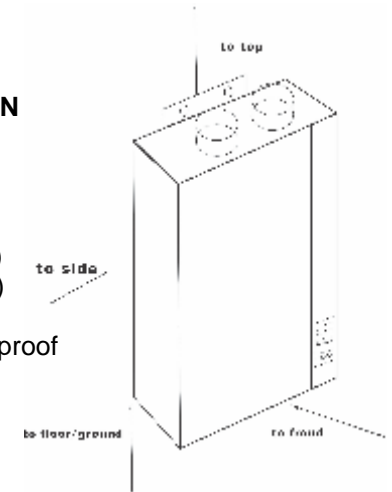

MOUNTING



The heater **MUST** be installed in a vertical position with fuel gas inlet at the bottom and exhaust vent positioned at the top. Installation in any other orientation will result in damage and will void warranty.

1. Identify a suitable location per the "Location and Clearance Guidelines". Ensure that the heater will be attached in a manner that is sufficient to support the weight of the heater in operation.
2. The system should only be mounted on a fire rated wall or piece of fire rated board that is mounted with spacers 1/3in (10mm) off the wall and protrudes at least 4in (100mm) beyond the sides of the water heater will have to be mounted. (Check with local codes).

3. Measure and mark the center locations for three (3) holes according to the installation measurements below.

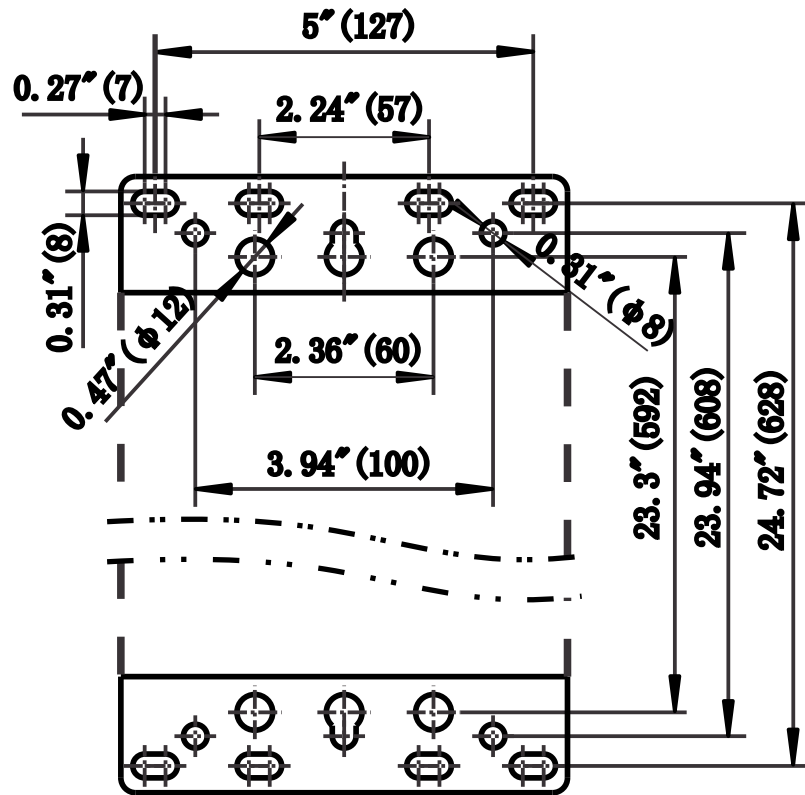

4. (For installation on Concrete or Block) Drill three each 5/16" (or 8 mm) holes at the marked locations. Insert the supplied 1/4" (6 mm) Steel expansion bolts into the holes.

5. (For wall installation) Locate a stud and use supplied mounting screws or hollow Wall Anchors. To use the hollow wall anchors, drill 5/16" holes at marked locations and insert the anchors into the hole. A combination of mounting screws and anchors is acceptable.

6. Remove the cover of water heater from carton.

7. Position the water heater into place. Fasten to the wall.



ELECTRICAL

WARNING

Ensure compliance with applicable electrical codes during installation including the U.S. National Electric Code (NFPA 70) or the Canadian Electrical Code – Part 1 (CGAS C22.1) depending on location.

1. Ensure that a properly grounded 120 V/60 Hz three prong outlet is available.

DO NOT PLUG IN THE UNIT UNTIL INSTALLATION IS COMPLETE, TESTED, AND READY FOR INITIAL START UP.

Optional WIRED REMOTE CONTROL

Choose a location for the optional wired controller to be installed per the following specifications and in compliance with all local code requirements.

1. The controller should be located out of the reach of small children.

2. Avoid installing in an area where set point can be adjusted by non-authorized personnel.

3. Avoid locations where the controller can become wet or be splashed.

4. The cable for the temperature controller shall be 18/2 Thermostat Wire. The maximum recommended cable length is 328' (100 m).

5. Pull wire from remote location to water heater location.

6. **ENSURE POWER TO WATER HEATER IS DISCONNECTED!** Remove cover from unit.

7. Terminate wires at the Remote Control Terminals as shown threading the wire through wire guides.



8. Attach the wires to the terminal connectors using Y shaped crimp connections or wrap the thermostat wires around the screws then fasten the screws to secure the terminal connectors. Inspect and insure that the Y connectors or the thermostat wires are not touching each other.

9. Mount controller to wall by drilling 2) 6mm holes 92mm (4") apart at installation location, and insert the Expansion Anchors supplied.

10. Remove the panel cover from the remote base, secure remote base to wall with (provided) screws.



11. Replace front cover.

12. Attach remote wires to the UNIT as follows:

1. Remove the front cover of unit.
2. Thread the cable through the access hole and wire bushing at bottom cover of unit and reinsert the wire bushing into the hole.
3. Remove the PCB and lift out of unit slightly to access wire terminal screws.
4. Insert the wire into terminals on PCB controller and tighten using a screw driver. If using Thermostat Wire proceed to step 5a.

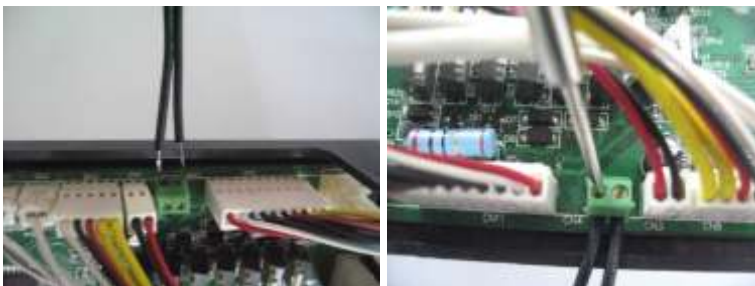

5. Reinstall the PCB controller and replace the front cover of unit.



GAS PIPING



WARNING Gas piping should be sized, installed, and tested only by a licensed professional! Improper installation can result in improper equipment performance or a hazardous situation.

1. Check the fuel gas type before installation. DO NOT connect a unit if the gas type is not compatible. Contact your dealer for the proper unit to match the gas type.
2. Check the gas inlet pressure immediately upstream at a location provided by the gas company. Ensure the gas pressure is within the limits shown in the Specifications section.
3. Review the installation location taking into account all gas users on site. Calculate the gas piping that will be required to service the installation. The gas supply line shall be sized and installed to provide a supply of gas sufficient to meet the maximum demand of the heater and all other gas consuming appliances at the location.

Note: Reference the National Fuel Gas Code, NFPA 54, for proper line sizing.

4. Ensure any compound used on the threaded joints of the gas piping is compatible with LPG/Propane or Natural Gas.
5. Use only approved materials to connect the unit to the gas line.
6. Install a manual gas valve in the gas supply line to the water heater. For best performance the water heater should be the first user downstream from the gas supply meter. A union can be used on the heater sized of the valve to allow for future servicing or disconnection of the unit.
7. Manufacturer recommends installation of gas pressure regulator (ex. Maxitrol 325-5A or equivalent) on gas line to ensure gas pressure is at optimum level for proper unit operation.
8. Purge the gas line of any debris and liquid before connection to the water heater.
9. Connect to the water heater.
10. Leak check all joints including the heater for gas tightness. Use a leak detection solution, soap and water, or an equivalent nonflammable solution, as applicable.

Ensure any leak check solution is non-corrosive and is completely rinsed from the piping after leak check is complete. Corrosion of the gas piping and subsequent leaks could occur. Never use flammable solutions or an open flame to test for gas leaks!

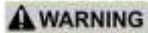

WATER PIPING

1. All piping, including soldering material, and components connected to this heater shall be approved for use in potable water systems.
2. If the heater has ever been previously used for heating non-potable water, never install the heater later into a potable water system.
3. The installation of manual shutoff valves, drain valves and unions are recommended. A professional should review each installation and ensure adequate ability to isolate, drain, and disconnect heater for service needs.
4. Connect suitable piping from water supply to the water heater. Note, water heater connections are ½” NPT.
5. Purge the water line to remove debris and air. Debris can plug and damage the heater.
6. Test water connections for leaks. Turn on water and purge water through the water heater and system. Flow for 1-2 minutes. Ensure all air is eliminated.
7. After filling and flushing the system, check the inlet water filter for debris and clean as required.
8. Consider insulation on hot water piping for energy conservation and personal protection. Do not insulate the pressure relief valve!



RELIEF VALVE

This unit requires an approved temperature and pressure relief valve. For protection against excessive temperatures and pressure, install temperature and pressure protective equipment required by local codes. The relief valve must be installed near the hot water outlet and must comply with Standard for Relief Valves for Hot Water Supply Systems, ANSI Z21.22 CSA 4.4.



Install proper drainage for discharge of temperature and pressure relief valves per local code when relief occurs and do not reduce or restrict line. Discharge line shall be installed to allow complete drainage of both valve and line. See the page for relief valve discharge.

Do not place a valve between the combination temperature and pressure relief valve and the water heater.



AIR INTAKE AND EXHAUST (VENT) SYSTEM



Improper venting of a water heater can result in excessive levels of Carbon Monoxide which can result in severe injury or death!

This water heater must be vented in accordance with the “Venting of Equipment” section of ANSI Z223.1 / NFPA 54 National Fuel Gas Code – latest versions, or in Canada, the most recent version of CAN/CGA B149.1 Natural Gas and Propane Installation Code. In addition, all installations must completely comply with all applicable local building codes. Failure to comply can result in equipment failure, fire, personal injury or death!



Use only stainless steel vent materials with this model! Plastic vent systems are not compatible and the failure of the vent system could result in damage, equipment failure, personal injury or death.



INTAKE AND VENT PIPE INSTALLATION SPECIFICATIONS

- For best results always minimize the length of the vent system. Keep the vent pipe routing as short and straight as possible.
- The water heater vent must not be combined with the vent from any other gas appliance or vent stack.
- The water heater vent must not be connected to a chimney.
- You must use vent components that are certified for use with this water heater as indicated within this manual. Do not combine components from multiple manufacturers.

- Air intake pipe may be ABS, PVC, galvanized steel, corrugated aluminum or other materials acceptable to local codes.

- The heater requires a direct vent. Exhaust vent must be of AL 29-4C® Stainless Steel vent directly to the outside of the building.

- The exhaust vent will have been tested to meet Underwriters Laboratories, Inc. to UL 1738 and ULC-S636.

- The system must use outside air for combustion. Ensure the incoming air is not contaminated by any potential source of fumes or chemicals.

- Avoid any dips or sags in horizontal pipe runs.

- Ensure vent piping is supported every four (4) feet (horizontal runs) or six (6) feet (vertical runs) or in accordance with local code requirements.

- Do not reduce the diameter of the vent piping.

- Ensure all vent connections are installed, properly connected, and sealed air tight per manufacturer's instructions.

- Any vent pipe seams should be installed so they are oriented on the top of horizontal pipe runs.

- Slope exhaust piping towards the exhaust terminal with a 2% slope (1/4 inch per foot; 19 mm/ m) to ensure rain or any accumulating condensate near termination are drained.

- A condensate collector is required for this system when there is a vertical vent configuration. A condensate collection point should be installed on the vertical run of piping just prior to the heater to ensure proper condensate drainage. Check with local codes for proper disposition and handling of condensate water, an air gaped drain is usually required and in some cases a condensate neutralization system is also required.

- Do not store hazardous or combustible materials near the vent piping

- Ensure the air intake and vent termination points are at least 12" (300 mm) above any possible snow accumulation level. The flows must not be impeded by snow or debris.

- Ensure the air intake and vent termination points are at least 24" (600 mm) from any obstruction or other objects.

The exhaust pipe must maintain adequate clearances and be insulated with a fireproof material if it passes through walls made of flammable materials. Consult local codes and vent pipe manufacture documentation for proper material selection and installation requirements.

CAUTION

If the heater will be installed in a building that has a system that maintains a negative pressure, it is possible for a back-draft to allow outside air to be pulled into the heater while not in operation. This can create a situation where freezing might occur within the heater. Please consult a professional for a properly designed venting solution or contact qualified technician for guidance.

AIR INTAKE PIPE ASSEMBLY

1. Drill 2 small holes at the end of the air intake pipe.
2. Slide the pipe over the air intake terminal.
3. Using a level, ensure the pipe is straight up and down.
4. With self tapping screws, attach the pipe to the air intake terminal.
5. Apply a bead of silicone around the pipe and air intake terminal, ensuring an air tight connection.

EXHAUST VENT PIPE ASSEMBLY

1. Use manufactures universal Adapter to connect the vent pipe to the unit.
2. Then follow the Manufactures vent pipe assembly guidelines and standard vent pipe location selection diagram below.

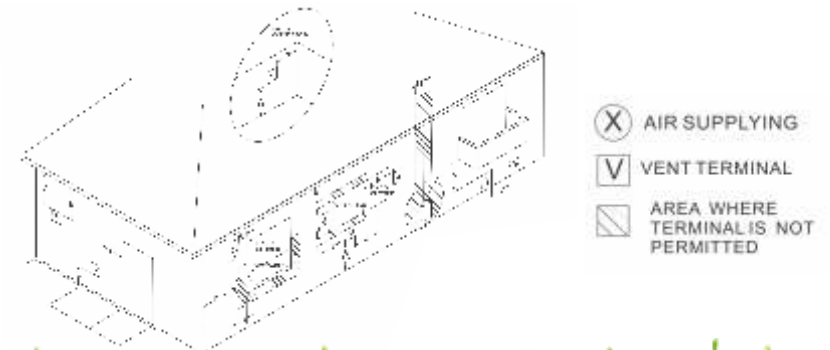

Ref.	Clearance Description	US Install	Canada Install
A	Above grade, veranda, porch, deck, or balcony.	12 inches (300 mm)	12 inches (300 mm)
B	To window or door that may be opened.	12 inches (300 mm)	36 (910 mm)
C	Permanently closed window.	*	*
D	Vertical to ventilated soffit, located above the terminal within a horizontal distance of 2 feet (61 cm) from the center line of the terminal.	*	*
E	To unventilated soffit.	*	*
F	To outside corner.	*	*
G	To inside corner.	*	*
H	To each side of center line extended above meter regulator assembly.	*	3 feet (910 mm) within a height 15 feet (4.5 m) above the meter/regulator assembly
I	To service regulator vent outlet.	*	36 inches (910 mm)
J	To non-mechanical air supply inlet to building or the combustion air inlet to any other appliance.	12 inches (300 mm)	36 inches (910 mm)
K	To a mechanical air supply inlet.	3 feet (91cm) above if within 10 feet (3000 mm) horizontally	6 feet (1.83 m)
L	Above paved sidewalk or paved driveway located on public property.	*	7 feet (2.13 m) **
M	Under veranda, porch, deck, or balcony.	*	12 inches (300 mm)

THIS TABLE IS PROVIDED FOR REFERENCE ONLY.

Please consult latest version of these standards to ensure installation is in compliance with current guidelines.

* For clearances not specified in ANS Z223.1/NFPA 54 or CSA B149.1, clearances are in accordance with local installation codes and the requirements of the gas supplier.

** A vent shall not terminate directly above a sidewalk or paved driveway that is located between two single family dwellings and serves both dwellings.

*** Permitted only if veranda, porch, deck, or balcony is fully open on a minimum of two sides beneath the floor.

Maximum Vent length

1. Determine the number of 90 degree elbows in the vent system (Two 45 degree elbows count as one 90 degree elbow).

2. Refer to below table to find the maximum vent length based on the number of elbows

Example: If you have one elbow, then your maximum vent length is 35ft (10.7m)

Number of 900 elbows						
0	1	2	3	4	5	6
41 feet (12.5m)	35 feet (10.7m)	29 feet (8.8m)	23 feet (7.0m)	17 feet (5.2m)	11 feet (3.4m)	5 feet (1.5m)



TERMINATION DETAILS

Vertical Terminations

The air intake requires a return bend or two 90° elbows to prevent entry of rain.

The vent termination and air intake must be in the same pressure zone.

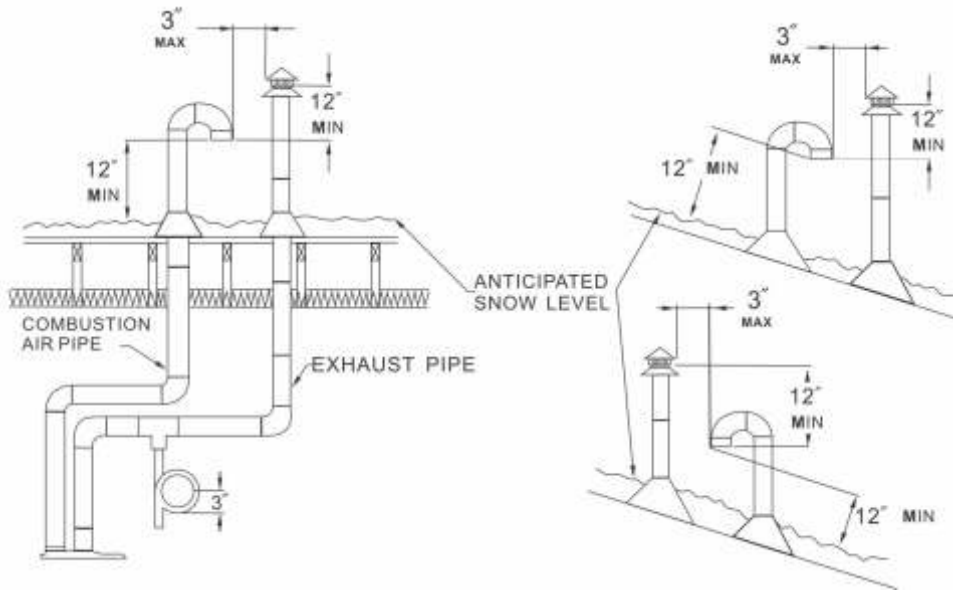

Horizontal Terminations

The air intake must be located in relation to the exhaust as shown below.

The air intake must 1/4 inch per foot to the termination to prevent entry of rain.

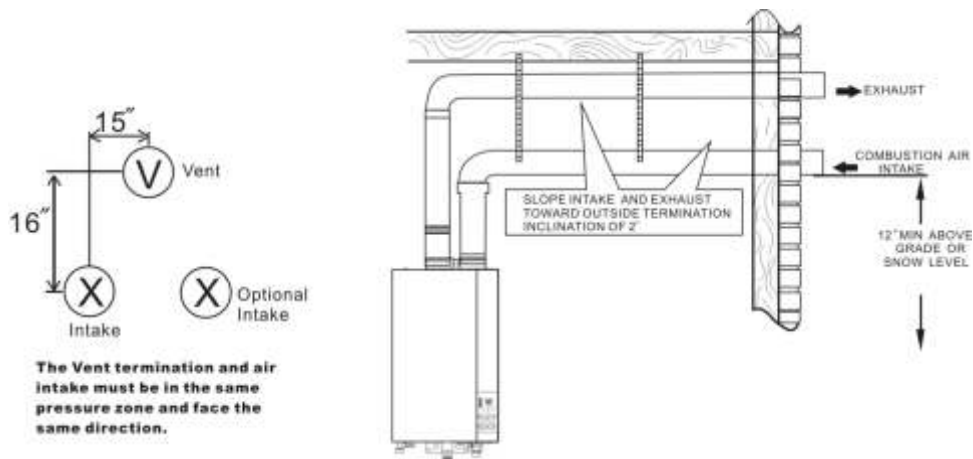

ACCEPTABLE VENT PRODUCTS

Manufacture	Product	Appliance Adapter	Horizontal Termination	Vertical Termination	Horizontal Concentric Termination	Vertical Concentric Termination
Z-Flex	Z-Vent	2SVSNA03.5 with AL-V0303B above and expander 2SVSIO304 Use another AL-V303B for PVC air intake	2SVSTPX04	2SVSRCF04	2SVSHTC43	NA
Hart & Cooley	Model SW	3SUTI with AL-V0304A above and expander 3SI4 Alternately use 3SANID with expander 3SI4 for intake air use AL-V303B for PVC air intake	4STWP	4SRC	4STM, 4CHT, 4C12, 4CTAI	4STM, 4CVT, 4CF(A,B,C), 7SSC, 4C36, 4CRC
Centrotherm Eco System	InnoFlue SW Vent System	For Air intake only this 3 inch system pipe can be used.				



START UP AND TESTING

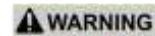

WARNING If the information in these instructions is not followed exactly, a fire or explosion may result causing property damage, personal injury or death.



Do not store or use gasoline or other flammable vapors and liquids in the vicinity of this or any other appliance.

WHAT TO DO IF YOU SMELL GAS:

- Do not try to light any appliance.
- Do not touch any electrical switch; do not use any phone in your building.
- Immediately call your gas supplier from a neighbor's phone.
- Follow the gas supplier's instructions.
- If you cannot reach your gas supplier, call the fire department.
- This appliance does not have a pilot. A built in ignition device will automatically light the burner. Do not try to light the burner by hand.
- Use only your hand to push in or turn the gas control knob. Never use tools. If the knob will not push in or turn by hand, do not try to repair it, call a qualified service technician. Force or attempted repair may result in a fire or explosion.
- Do not use this appliance if any part has been under water. Immediately call a qualified service technician to inspect the appliance and to replace any part of the control system and any gas control that has been under water.



INITIAL START UP

1. STOP! Read the safety information from the previous page.
2. Ensure unit is unplugged and all electric power to the appliance is off.
3. Locate the manual gas valve to the heater. Open the manual gas valve for 15-30 seconds.
4. Turn the manual valve clockwise to the full OFF position.
5. Carefully check for any sign or smell of gas. If gas is detected, wait five (5) minutes for it to clear. STOP and go no further until gas leak point is detected.
6. If no gas is detected, open the manual gas valve for five (5) minutes and again check area for any signs of gas. At any sign of gas, STOP and go no further. Follow the safety precautions from the previous page.

7. If no gas is detected, proceed.
8. Open the water supply valve to the unit. Inspect for any leaks.
9. Visually inspect air intake inlet and exhaust piping to ensure they are not obstructed.
10. Plug in the unit. "CL" is displayed indicated "cold".
11. Press the "ON" button to turn on the unit.
12. Adjust the temperature set point per "Temperature Control" Section of this manual.
13. This appliance is equipped with an ignition device that automatically lights the burner. Do not try to light the burner by hand.
14. Open a hot water tap to a flow above the minimum flow point (0.66 gpm/ 2.5 l/min).
15. The burner control system will fire the igniter, the burner will light, and hot water will be produced.
16. If the heater will not operate, follow the shut down instructions. Wait 5 minutes and attempt to repeat this start up procedure.
17. If system does not operate, begin troubleshooting per "Trouble Shooting" section of this manual. Contact qualified technician for assistance.



REFERENCE

WIRING DIAGRAMS

GASETL wiring diagram (without wired remote)

GASETL wiring diagram (with wired remote)

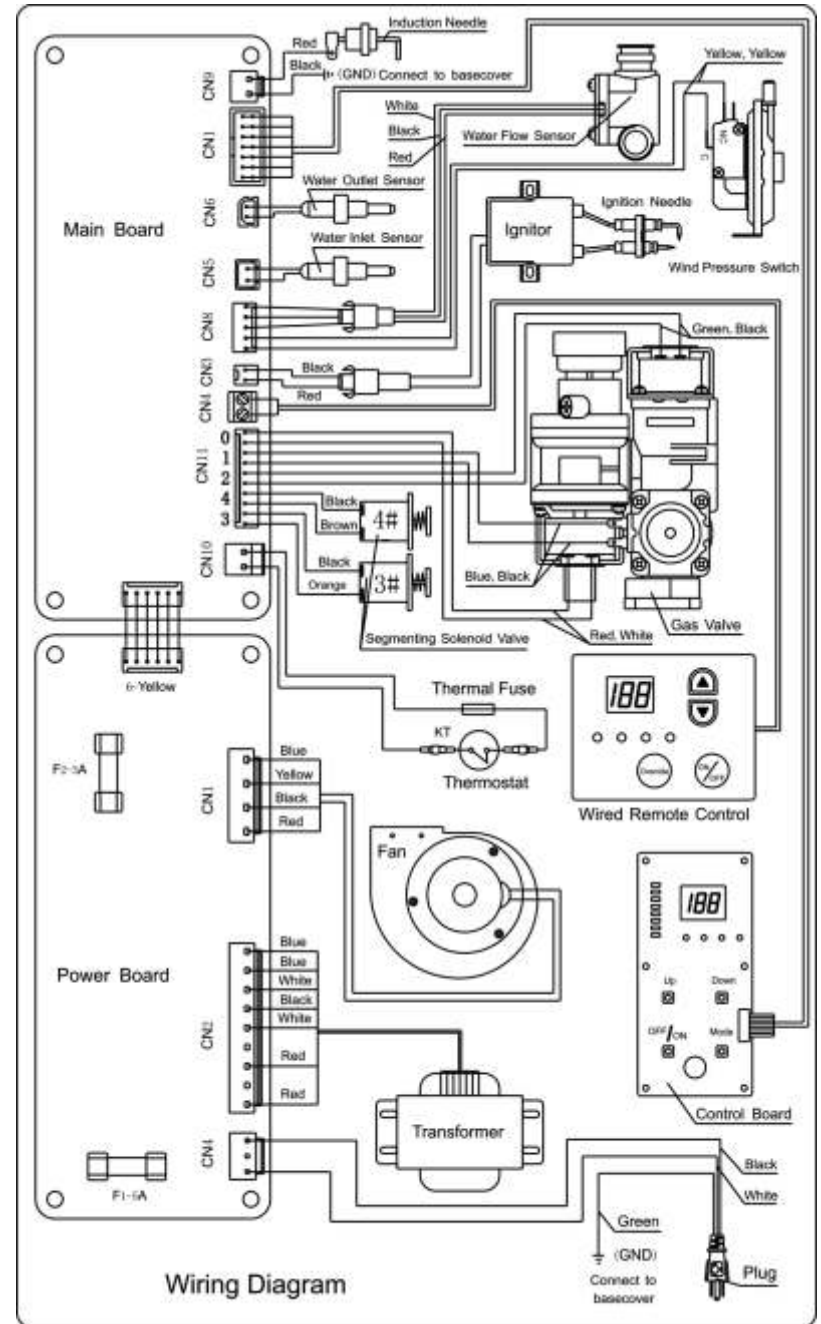
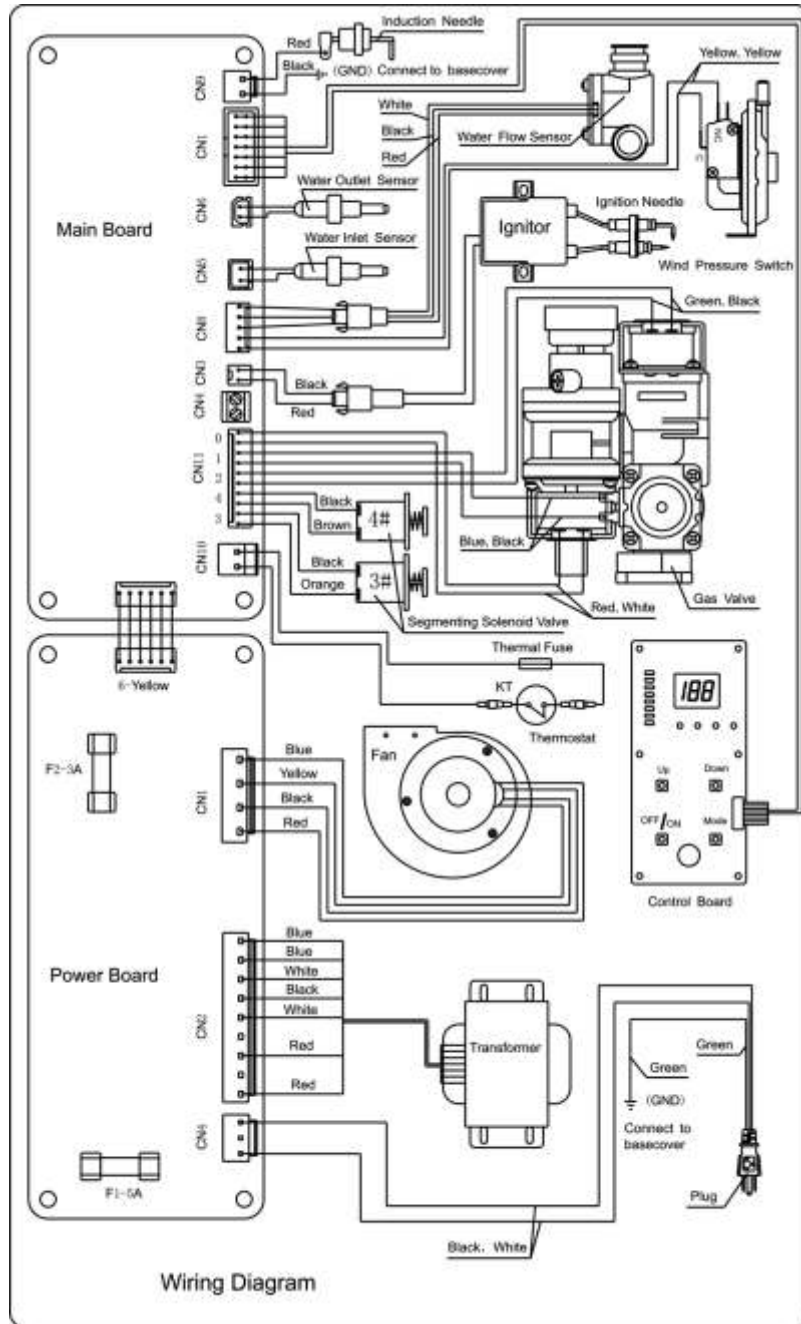



SYSTEM SPECIFICATIONS

TECHNICAL SPECIFICATIONS		GA16ETL
Type of Appliance		Temp. controlled continuous Flow Gas Hot Water Unit
Operation		With/without remote controls, mounted in kitchen, bathroom, etc
Flue System		Room Sealed-Forced Draught Flue
Available default Temperatures		Factory setting 107°F
Rated gas pressure	Natural Gas	7 inch W.C.(1 740Pa)
	Propane (LPG)	11 inch W.C.(2 740Pa)
Temperature Range		Within 95°F ~149°F (35°C ~65°C)
Width x Height x Depth		14" x 22" x 6" (353mm x 568mm x 142mm)
Weight		35lbs (16kg)
Connections	Gas	½ in.NPT
	Cold Water Supply	½ in.NPT
	Hot Water Supply	½ in.NPT
Ignition System		Direct Electronic Ignition
Max./Min. Gas Consumption	Natural Gas	110,000 Btu/h-20,000 Btu/h
	Propane Gas	107,000 Btu/h-20,000 Btu/h
Hot Water Delivery Capacity Max		4.2 GPM (45°F rise) 5.4 GPM (35°F rise)
Noise level		70 dB(A)
Thermal efficiency		0.82
NOXaf		40 ppm Max
Minimum Operating Water Flow		0.66 GPM (2.5 L/min)
Minimum Operating Pressure		1.45 PSI (0.1 bar)
Power Supply		120 Volts ~ 60Hz
Water temperature control		Input and output water temperature signals
Water flow control		Electronic Water flow sensor
Safety Device	Flame Failure	Flame rod
	Boil dry	Water flow sensor /194°F thermistor
	Over temperature	185°F (Integrated circuit system)
	Fusible link	320°F Thermal Fuse
	Pressure relief valve	Opens 145 PSI
	Combustion fan rpm check	Integrated circuit system
	Over current	Glass fuse (5 Amp/3Amp)
Remote Control Cable Optional	Bathroom, Second Bathroom, Kitchen, (universal / Up to 3 Controllers)	Kitchen/Bathroom/Second Bathroom (universal / Up to 3 Controllers)
Electrical Consumption(Normal)		55W



DIMENSIONS

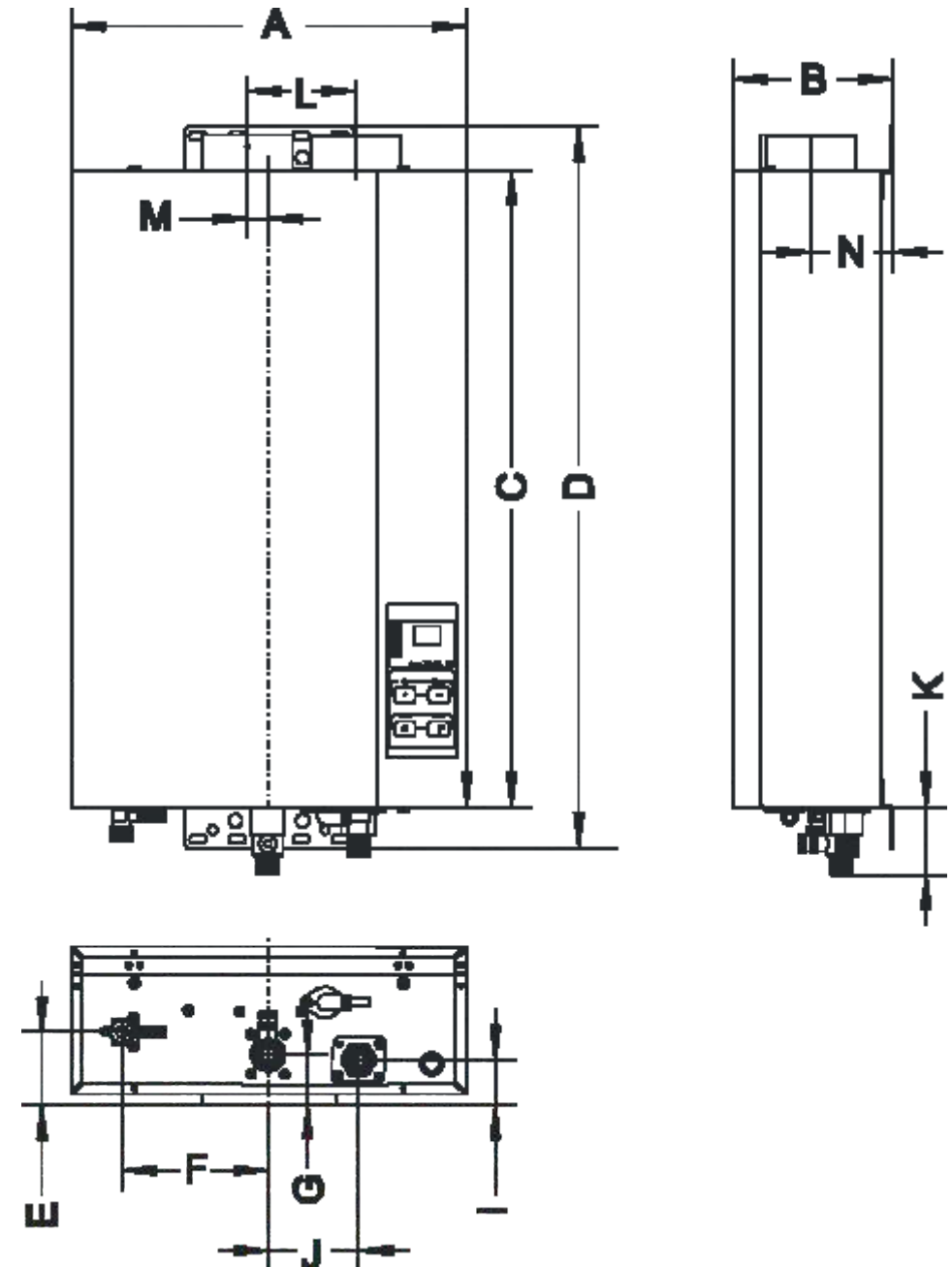

DIM	DESCRIPTION	Inches (mm)
A	Width	13.90 (353)
B	Depth	5.59 (142)
C	Height-Unit	22.37 (568.2)
D	Height-with brackets	25.43 (646)
E	Hot Water Outlet-from wall	2.59 (65.8)
F	Hot Water Outlet-from center	5.16 (131)
G	Cold Water Inlet-from wall	1.80 (45.8)
(H)	Cold Water Inlet-from center	0.04 (1)
I	Gas Connection-from wall	1.57 (39.8)
J	Gas Connection -from center	3.15 (80)
K	From base to gas valve connection	1.78 (45.2)
	From base to cold water inlet connection	2.38 (60.4)
	From base to hot water outlet connection	1.24 (31.4)
L	Air intake center to gas exhaust center	3.82 (97)
M	Gas exhaust center to unit center	0.75 (19)
N	Air intake center to wall	2.82 (72)
	Gas exhaust center to wall	3.04 (77.3)



NAMES OF MAJOR PARTS AND COMPONENTS

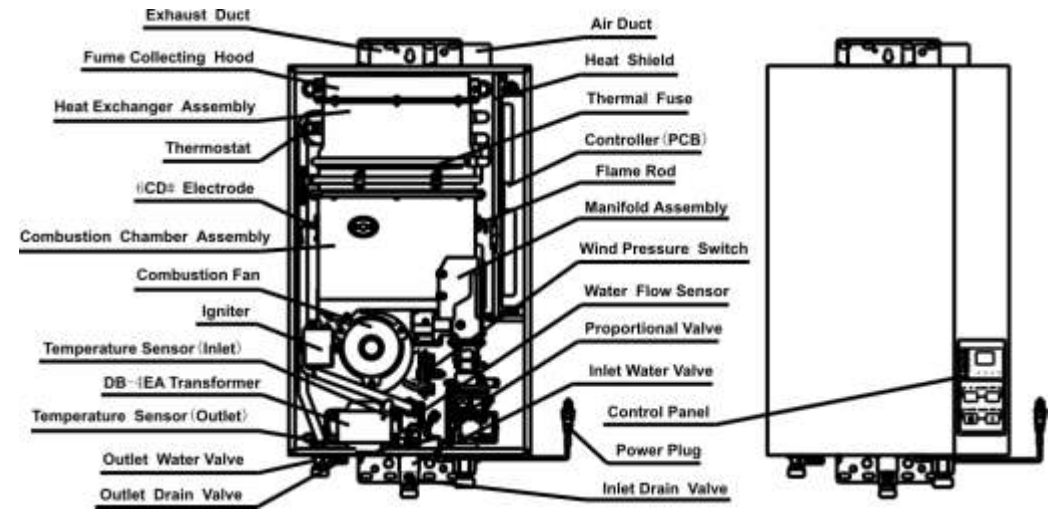

TEMPERATURE INCREASE CHART

	Points of Use	Temp. Increase at Typical per Faucet Flow Rate (Hot Side)*	Temp. Increase at Max Possible Flow Rate	Max Possible Flow Rate per Faucet
For incoming water temperatures below 68°F	1	100 (1 GPM Typical)**	72	2.25 GPM
	2	90 (.75 GPM Typical)	72	1.15 GPM
	3	85 (.6 GPM Typical)	72	.75 GPM
	4	80 (.5 GPM Typical)	72	.6 GPM
	5	72 (.45 GPM Typical)	72	.45 GPM
For incoming water temperatures above 68°F	1	100 (1 GPM Typical)**	72	4 GPM
	2	90 (1 GPM Typical)	72	2 GPM
	3	85 (1 GPM Typical)	72	1.3 GPM
	4	80 (.75 GPM Typical)	72	1 GPM
	5	72 (.65 GPM Typical)	72	.8 GPM

*Typical flow rates are based on 40 PSI to the home and faucets with standard flow restrictors. Higher PSI and unrestricted faucets may result in higher flow rates, which may result in a maximum temperature increase of 72°F.

**Incoming flow rates lower than 1 GPM through the water heater, or incoming water temperatures higher than 80°F, may result in water heating to higher than its set point. Avoid scalds!! Always test the water with your hand before using it to be sure that cold water doesn't need to be mixed in first.



CUSTOMER SERVICE

At Marey, we pride ourselves on the excellence of our customer service and support team.

Please feel free to contact us if you have any questions about our products, warranty service, or if you need assistance installing a unit. We also strive for continuous improvement, so we welcome your comments, feedback and suggestions.



1-855-MAREY-55
customerservice@marey.com



OTHER PRODUCTS

Marey proudly manufactures water heaters and accessories for use in almost any application. Please visit our website to learn more about other Marey products.



GAS PORTABLE



POWER PAK



SANTON



AQUAMATIC



ECO180



POWER GAS



Delbrey Street, 211
San Juan, Puerto Rico
00912
Tel: 1-512-332-2229
Toll Free: 1-855-627-3955
1-855-MAREY-55

www.marey.com