

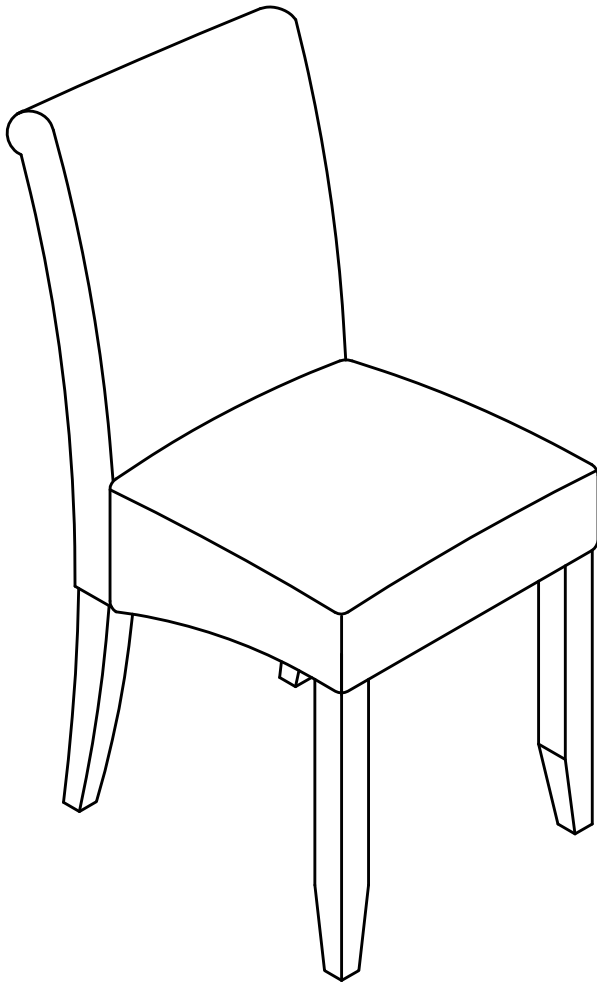

MET86

ECO LEATHER PARSONS CHAIR

OPERATING INSTRUCTIONS



WARNING

1. Do not use this product unless all screws and bolts are securely tightened.
2. Check that all screws and bolts are tight every three months or as needed.
3. Dispose of packing material properly. Do not use plastic cover as head covering. It may cause suffocation.
4. Do not use this product as a stepladder.
5. Use this product for its intended purpose only.
6. **Intended for residential use only.**

LIMITED WARRANTY

OSP Designs Warrants, to the original purchaser its products to be free from defects in material and workmanship for a period of 90 days. Defects and damage from misuse, abuse, negligence, alteration, accident, vandalism, rusting, acts of nature or any other event beyond the control of OSP Designs is not covered. The warranty does not cover cosmetic damage that may result from normal use. Liability for incidental or consequential damages is excluded. The user assumes all risk of injury resulting from use of this product. This warranty gives you specific legal rights, and you may also have other rights which vary from state to state.

To make a warranty claim, contact Customer Service, provide model number, sales receipt and description of the problem. It is the customer's responsibility to prepay freight on any components returned to the factory. OSP Designs will pay return freight on components covered under terms of warranty.

Our quality standards are among the highest in the industry. Sometimes, no matter how hard we try, there are times when hardware is missing. Our Parts Department will do everything possible to promptly remedy the problem. Contact us via email parts@officestar.net, by Fax 1-909-930-5629, or toll free parts number 1-800-950-7262, Monday through Friday 8:00 a.m. - 5:00 p.m. Pacific Time. OSP Designs P.O. Box 3520 Ontario, California 91761 USA

MET86

ECO LEATHER PARSONS CHAIR

ASSEMBLY INSTRUCTIONS

IMPORTANT NOTE:

1. Use hand tools only for assembly as power tools may cause damage
2. Carefully remove any staples used for packaging.

PART	QTY
1. Chair Back	1
2. Seat Frame	1
3. Right Front Leg	1
4. Left Front Leg	1
5. Flat Washer	9
6. Lock Washer	9
7. Short Screw	5
8. Long Screw	4
9. Dust Barrier	1
10. Allen Wrench	1

STEP 1

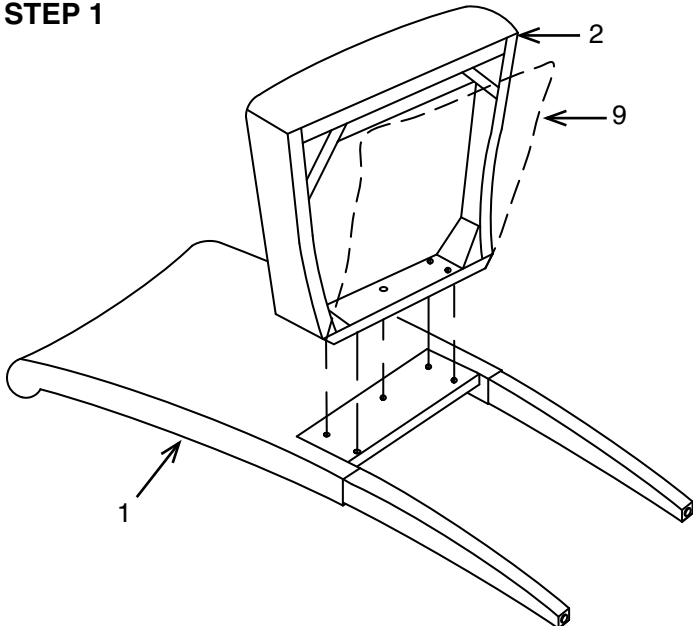

STEP 2

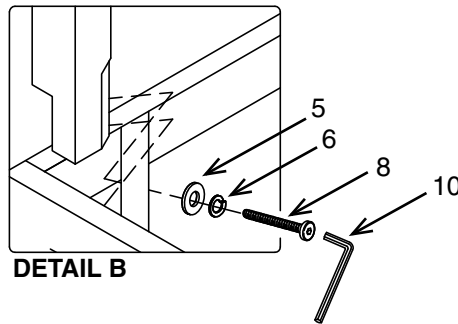
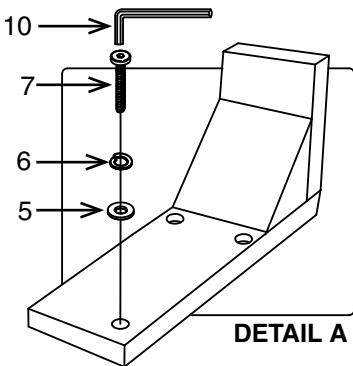
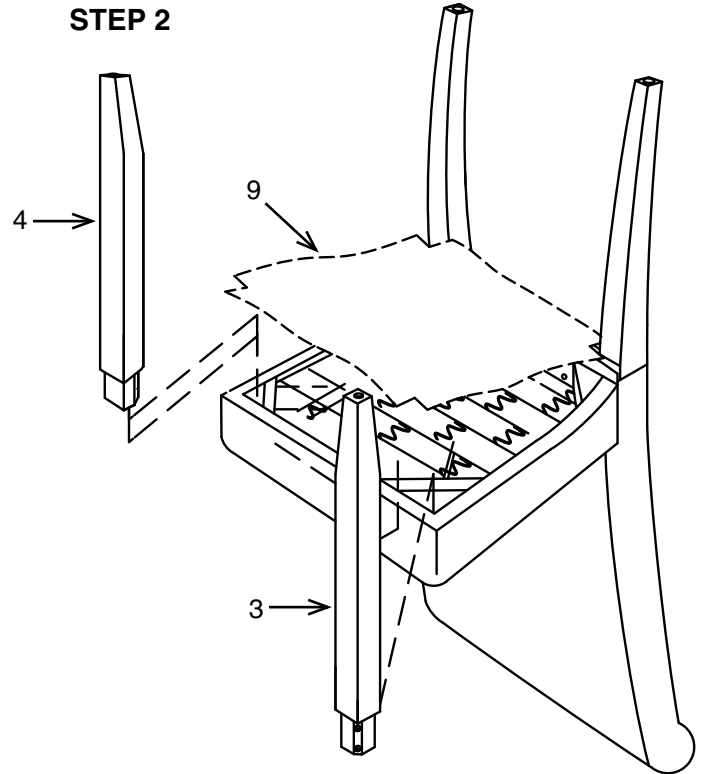

Remove all parts from carton, separate by part numbers indicated on parts list, and verify part quantities.

STEP 1 Place Chair Back (1) on a soft surface. Align the holes on the Chair Back (1) with the holes on the Seat Frame (2). Secure the Seat Frame (2) to the Chair Back (1) using five Flat Washers (5), five Lock Washers (6) and five Short Screws (7),

AS SHOWN IN DETAIL A. TIGHTEN ALL SCREWS USING ALLEN WRENCH (10).

STEP 2 Attach Right Front Leg (3) and Left Front Leg (4) to Seat Frame (2) using two Flat Washers (5), two Lock Washers (6) and using two Long Screws (8) for each leg. **SEE DETAIL B. DO NOT FULLY TIGHTEN SCREWS.** Turn chair to the upright position, apply firm pressure to align and **FULLY TIGHTEN ALL SCREWS USING ALLEN WRENCH (10)**, Secure Dust Barrier (9) to bottom of Seat Frame (2) using pre-installed hook and loop material.

ATTENTION: MAKE SURE ALL SCREWS ARE FULLY TIGHTENED BEFORE USING CHAIR.