

AUTOMATIC ICE MAKER INSTALLATION INSTRUCTIONS

An authorized service technician is recommended to install the ice maker kit.



WARNING

- To avoid electric shock, which can cause death or severe personal injury, disconnect the refrigerator from electrical power before connecting a water supply line to the refrigerator.
- Connect the ice maker to a potable water supply only.



NOTE

Check with your local building authority for recommendations on water lines and associated materials prior to installing your new refrigerator. For household water line hookup from the home water supply system to the unit, Frigidaire recommends for homes with existing valves its **Smart Choice**® water line kit 5304437642 (with a 6 ft. Stainless Steel Water Line) and for homes without an existing valve, Frigidaire recommends its **Smart Choice**® water line kit 5304493869 (with a 6' Polyline Waterline). Please refer to www.frigidaire.com/Filters--Accessories/Refrigerator-Accessories for more information.

Tools Needed:

- | | |
|--------------------------|------------------------------|
| • Flat head screw driver | • Phillips or Quadrex driver |
| • ¼" Hex driver | • Gloves |
| • Drill | • Needle nose pliers |

Ice Maker (IM117000) Kit Components

Parts needed for install inside the unit



Parts needed for install on back side of the unit

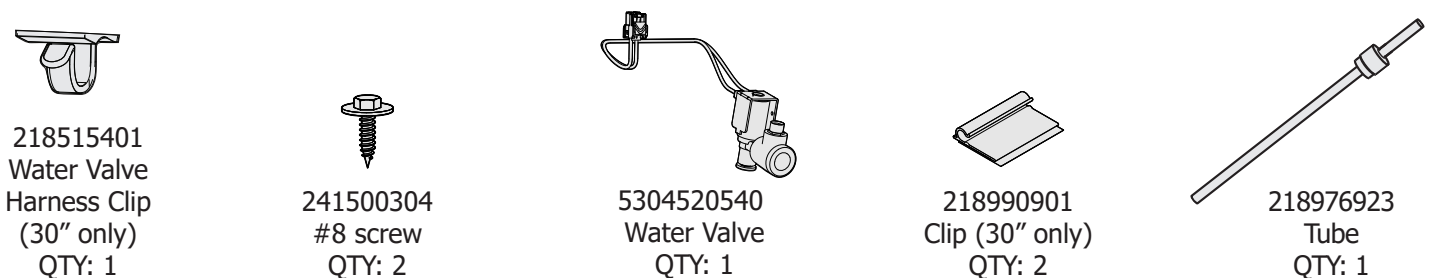

Ice Maker Installation Instructions

1. Unplug refrigerator from electrical outlet.
2. Lift the freezer shelf up and out. Set aside.

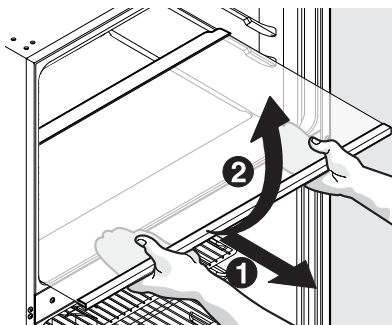

3. Remove water inlet and electrical cover, located on the inside of the unit, by inserting a flathead screwdriver into the left side of the opening in the small cover. Push to the right to disengage the snap.

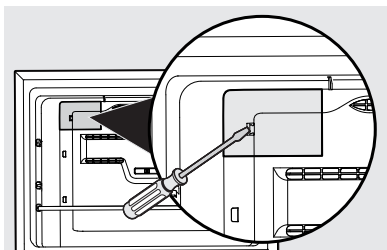

4. Locate dimples in the liner for screw placement (a flashlight may help). Insert 5 shoulder screws in the freezer: 2 screws on the left side wall, and 3 on the top of the liner. Screw until shoulder screws are flush with the liner.

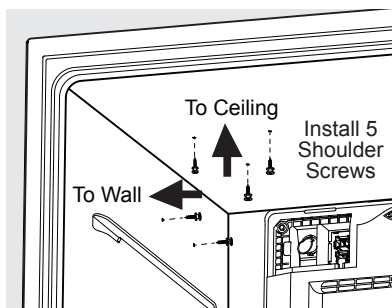

5. For **30" wide refrigerator** install bracket onto ice maker. Ice maker will slide onto mounting features on bracket and snap into place. The locking feature is located on the rear of the ice maker.

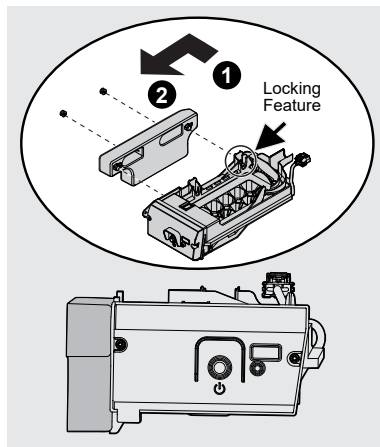

30" wide refrigerator

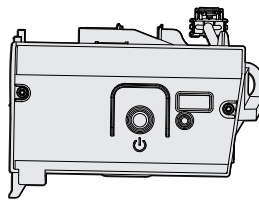

28" wide refrigerator
Use the ice maker only

6. Plug the ice maker in the electrical connector on the back wall.

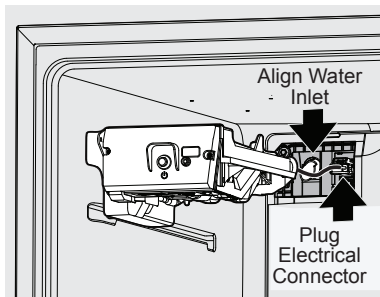

Make sure the ice maker water channel is under the water fill tube, and then slide the ice maker on the 2 side wall shoulder screws. The ice maker will snap into place.

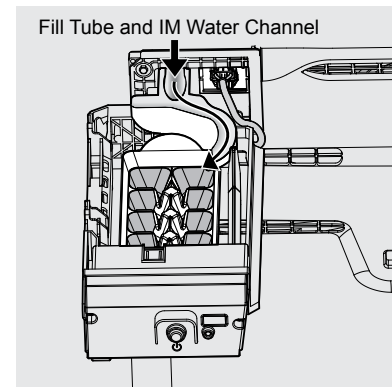

Ice Maker Installation Instructions

7. Install ice maker housing onto shoulder screws on the top of the unit until it locks into place with a snap.

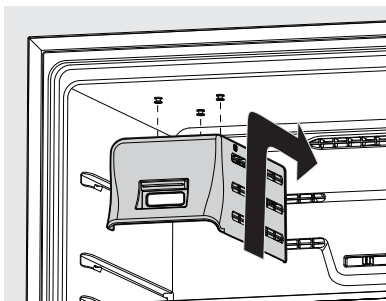

8. To install the ice bucket, the freezer shelf needs to be in the lowest position. Slide the ice bucket between the side wall and the right side of the ice maker housing positioned on the shelf.

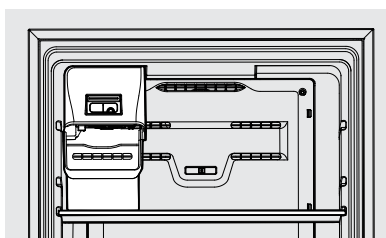

9. Locate the Ice maker installation label on the rear outside right top corner of the refrigerator. Cut the label on the dashed lines, and push flaps inward until they stick to the unit.

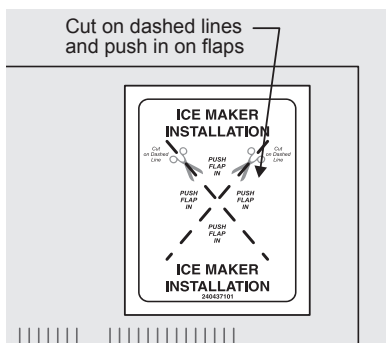

10. Install the water line by screwing the nut on the end of the tube onto the water inlet. Tighten the nut with needle nose pliers to a snug +1/4 turn.

11. Install the 2 water line clips on the unit evenly spaced inside the depressed area located under the water inlet. Insert the water line tube into the clips.

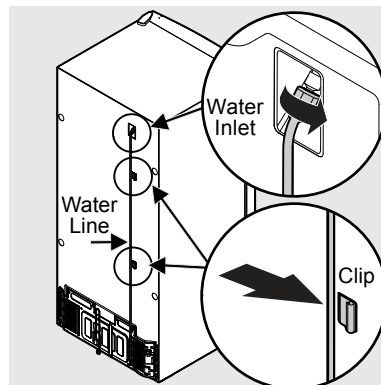

***If you have a unit with an access cover, continue to page 4 for additional installation instructions. For a unit without an access cover, continue to page 5.**

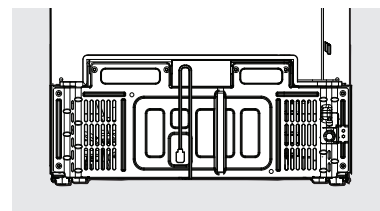

Units with access cover

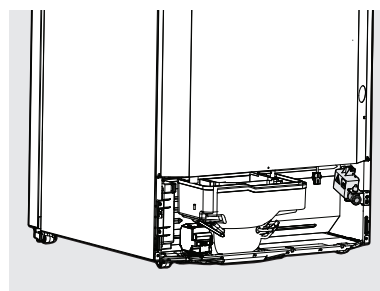

Units without access cover

Ice Maker Installation Instructions (with access cover)

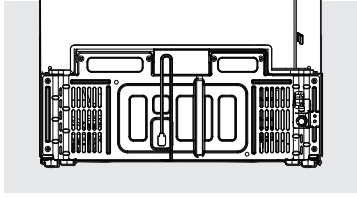

CAUTION

Wear gloves and use extreme CAUTION when handling the access cover.

12. Remove 8 screws from access cover located at the bottom rear outside of the unit. Set aside.

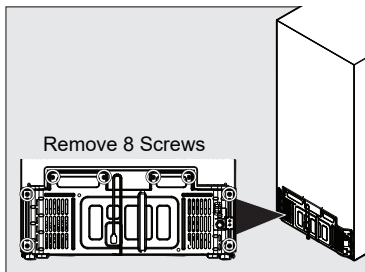

13. Place the water tube into the bottom outlet of the water valve. The tube should be pushed into the valve up to the black line marked on the tube. Check to make sure the tube is installed correctly.

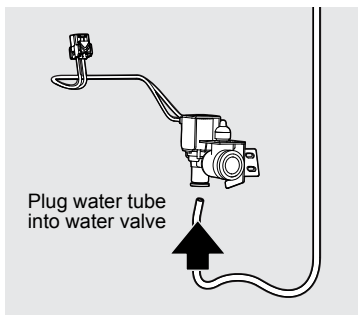

14. The water valve location has pre-drilled holes on the right rear of the unit. The water line should be oriented down when valve is installed. Install the water valve using a 1/4" hex head driver, install the 2 hex head screws. Tighten screws to a snug +1/4" turn.

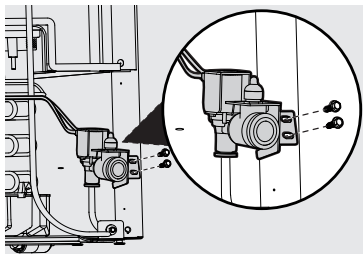

15. Plug connector on water valve wire harness into the connector at top of appliance compartment. Install the water valve clip at the bottom right side of the unit, and route and attach the water valve harness into the clip.

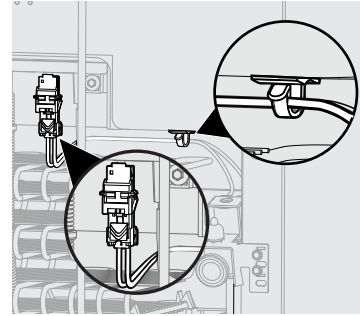

16. Remove water valve punch out in access cover with pliers.

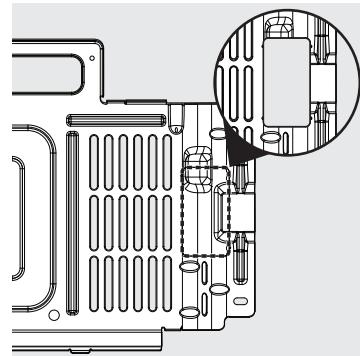

17. Reinstall the access cover by hooking cover onto the bottom flange of the cabinet, then lift up to align with the screw locations on the cabinet. Install the screws starting with the 2 on the left side, then the right side, finish with the center screws.

NOTE

Ensure power cord is aligned with the notch at the bottom of the access cover and the water line is located on the notch at the top right of the cover.

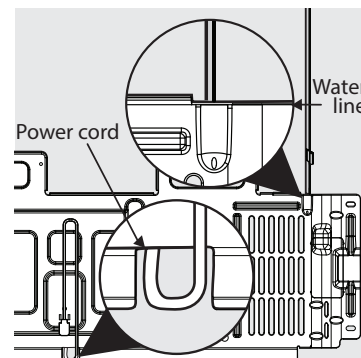

18. Connect the household water line to the water valve. Follow instructions on page 7.

Ice Maker Installation Instructions (without access cover)

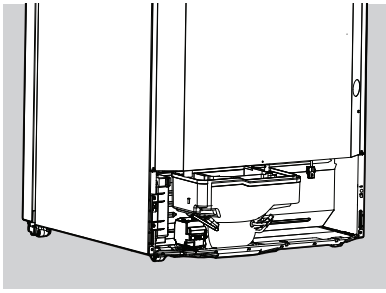

19. Remove the connector box from the unit with a Philips screwdriver.

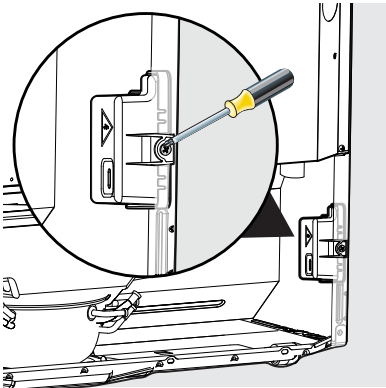

20. Open the connector box using a flat head screwdriver. Insert at the notched point and turn. Insert the water valve in the hole in the box.

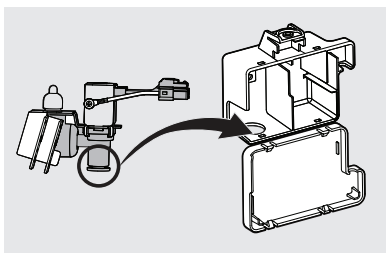
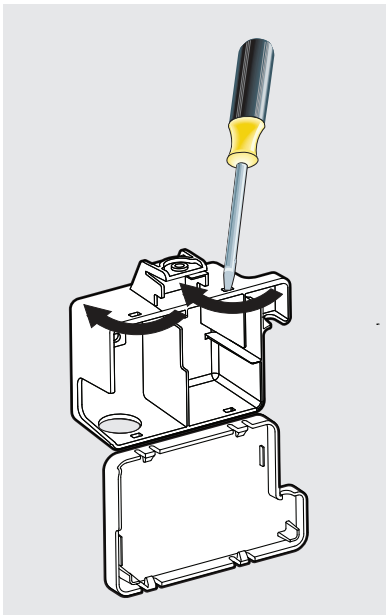

21. Connect the valve wire harness with the AC connector. Insert the wiring in the box as shown. Close the box cover completely, ensuring all wiring is inside.

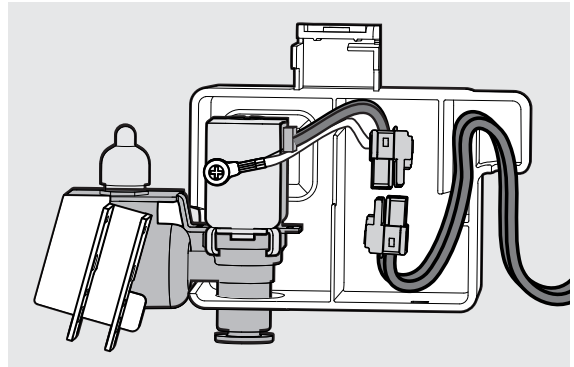

22. Plug the water tube from the unit into the bottom outlet of the water valve. The tube should be pushed into the valve up to the black line marked in the tube.

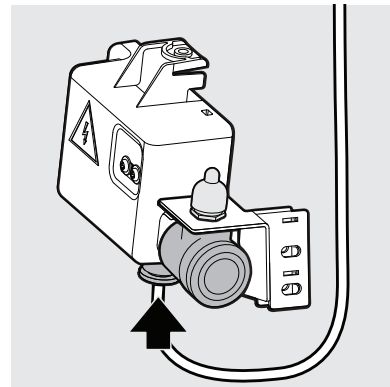

23. Attach the water valve bracket to the unit at the 2 pre-drilled holes using the 2 screws included in the kit.

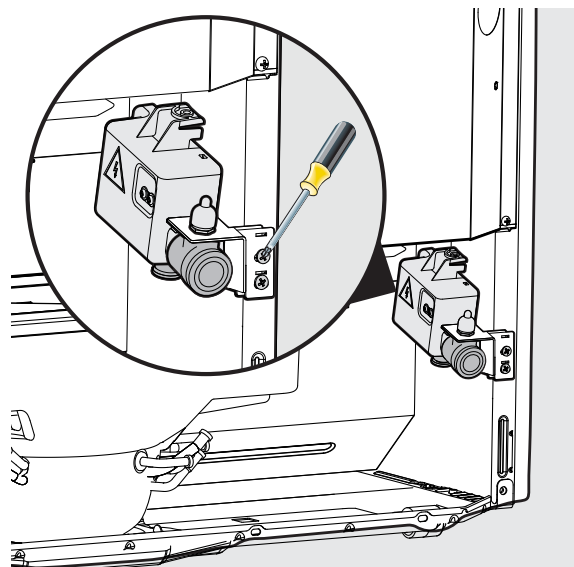

24. Connect the household water line to the water valve. Follow instructions on page 7.

Connecting Ice Maker to Water Supply

WARNING

To avoid electric shock, which can cause death or severe personal injury, disconnect the refrigerator from electrical power before connecting a water supply line to the refrigerator.

CAUTION

To Avoid Property Damage:

- Stainless Steel braided tubing is recommended for the water supply line. Water supply tubing made of ¼ in. plastic is not recommended to be used. Plastic tubing greatly increases the potential for water leaks, and the manufacturer will not be responsible for any damage if plastic tubing is used for the supply line.
- DO NOT install water supply tubing in areas where temperatures fall below freezing.
- Chemicals from a malfunctioning softener can damage the ice maker. If the ice maker is connected to soft water, ensure that the softener is maintained and working properly.

IMPORTANT

Ensure that your water supply line connections comply with all local plumbing codes.

Before Installing The Water Supply Line, You Will Need:

- Basic Tools: adjustable wrench, flat-blade screwdriver, and Phillips screwdriver
- Access to a household cold water line with water pressure between 30 and 100 psi.
- A water supply line made of ¼ in. (6.4 mm) OD, stainless steel tubing. To determine the length of tubing needed, measure the distance from the ice maker inlet valve at the back of the refrigerator to your cold water pipe. Then add approximately 7 ft. (2.1 m.), so the refrigerator can be moved out for cleaning.
- A shutoff valve to connect the water supply line to your household water system. DO NOT use a self-piercing type shutoff valve.
- Do not reuse compression fitting or use thread seal tape.
- A compression nut and ferrule (sleeve) for connecting a copper water supply line to the ice maker inlet valve.

NOTE

Check with your local building authority for recommendations on water lines and associated materials prior to installing your new refrigerator. Depending on your local/state building codes, Frigidaire recommends for homes with existing valves its **Smart Choice**® water line kit 5304437642 (with a 6 ft. Stainless Steel Water Line) and for homes without an existing valve, Frigidaire recommends its **Smart Choice**® water line kit 5304493869 (with a 6' Polyline Waterline). Please refer to www.frigidaire.com/Filters--Accessories/Refrigerator-Accessories for more information.

Connecting Ice Maker to Water Supply

To Connect Water Supply Line To Ice Maker Inlet Valve

1. Disconnect refrigerator from electric power source.
2. Place end of water supply line into sink or bucket. Turn ON water supply and flush supply line until water is clear. Turn OFF water supply at shutoff valve.
3. Remove plastic cap from water valve inlet and discard cap.
4. **If you use copper tubing**, slide brass compression nut, and then ferrule (sleeve) onto water supply line. Push water supply line into water valve inlet as far as it will go ($\frac{1}{4}$ in. / 6.4 mm). Slide ferrule (sleeve) into valve inlet and finger tighten compression nut onto valve. Tighten another $\frac{1}{2}$ turn with a wrench; **DO NOT** overtighten. See below.

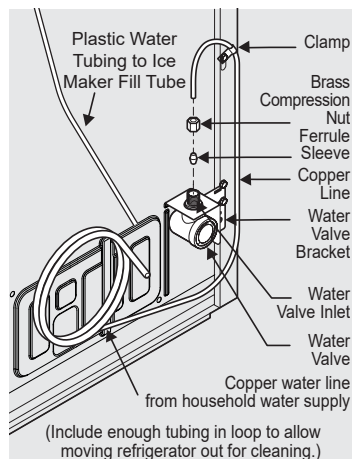

Units with access cover

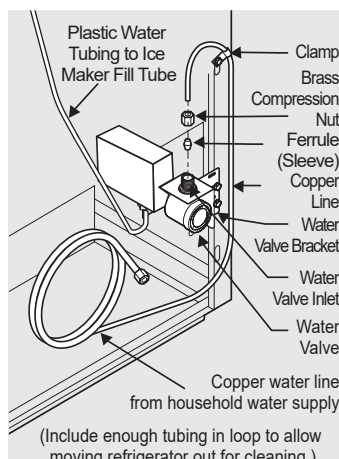

Units without access cover

If you use braided flexible stainless steel tubing, the nut is already assembled on the tubing. Slide nut onto valve inlet and finger tighten nut onto valve. Tighten another $\frac{1}{2}$ turn with a wrench; **DO NOT** overtighten. See below.

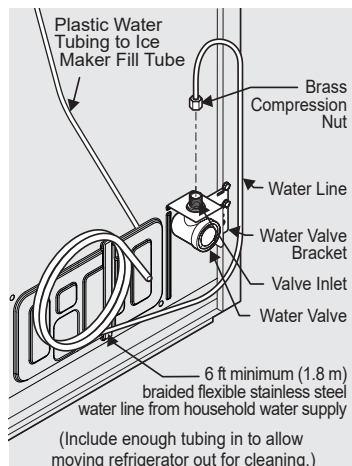

Units with access cover

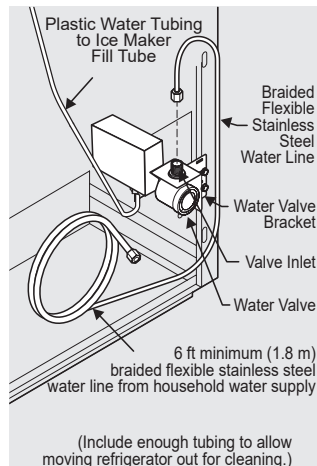

Units without access cover

5. With steel clamp and screw, secure water supply line (copper tubing only) to rear panel of refrigerator as shown.
6. Coil excess water supply line (copper tubing only), about $2\frac{1}{2}$ turns, behind refrigerator as shown and arrange coils so they do not vibrate or wear against any other surface.
7. To turn ice maker on, press the ice maker's On/Off power switch so the LED is steadily illuminated.

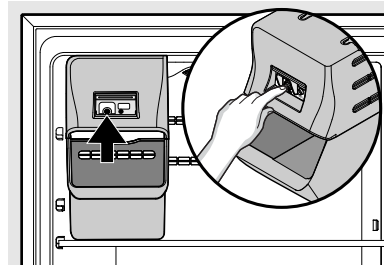

8. Turn ON water supply at shutoff valve and tighten any connections that leak.
9. Reconnect refrigerator to electrical power source.

Ice Service

If your refrigerator has an automatic ice maker, minimal ice will be produced during the first 24 hours of operation. Air in new plumbing lines may cause the ice maker to cycle 2 or 3 times before making a full tray of ice. With no usage, it will take approximately 1 to 2 days to fill the ice container.

New plumbing connections may cause the first production of ice cubes to be discolored or have an odd flavor. Discard ice made during the first 24 hours.

Turning Your Ice Maker On

After the plumbing connections have been completed, the water supply valve must be opened. Place the ice container under the ice maker, pushing it as far back as possible. Press the ice maker's On/Off  button.

Turning Your Ice Maker Off

To stop the ice maker, press the ice maker's On/Off  button. The ice maker also turns off automatically when the ice container is full.

IMPORTANT

To ensure proper function for your ice maker, hook up water supply immediately or turn ice maker OFF. If the ice maker is on and the water supply is not connected, the water valve will make a loud chattering noise.

Ice Production: What To Expect

The ice maker will produce 2 to 2.5 pounds of ice every 24 hours depending on usage conditions. Ice is produced at a rate of 10 cubes every 100 to 160 minutes.

CAUTION

Do Not place the ice container in your dishwasher.

Ice Maker Tips

Remember that water quality determines your ice quality. If the water source uses a water softener, ensure that the softener is maintained and working properly. Chemicals from a malfunctioning softener can damage the ice maker.



CAUTION

Do Not place the ice container in your dishwasher.

- Wash ice container in warm water with mild detergent. Rinse well and dry.
- Stop the ice maker when cleaning the freezer or for short vacations.
- If the ice maker will be turned off for a long period of time, turn the water supply valve to the closed position.