

MODEL: 32204

PACKING DIAGRAM

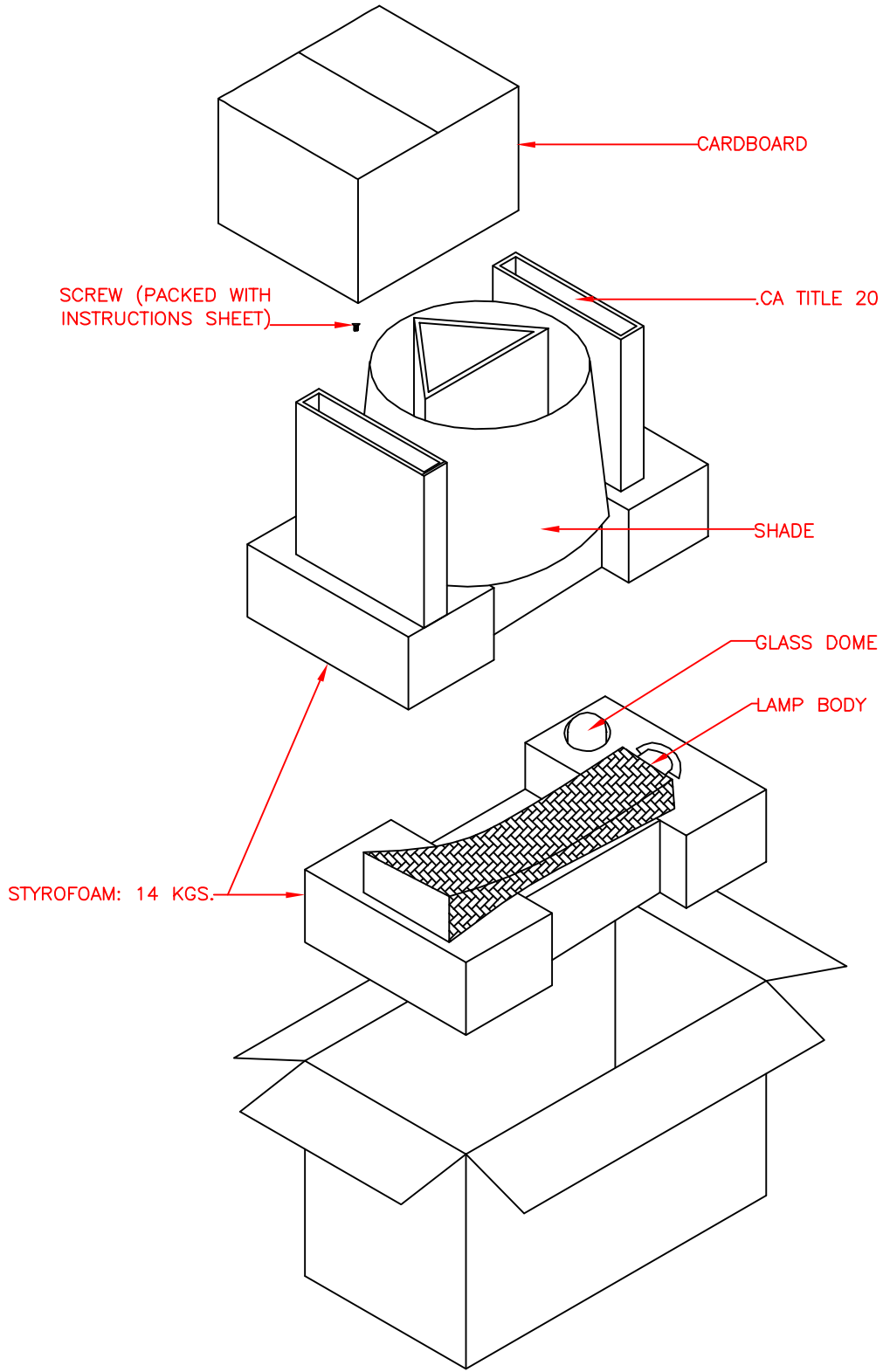



ALL•TOGETHER•BETTER

USE AND CARE GUIDE

OUTDOOR TABLE LAMP-100W

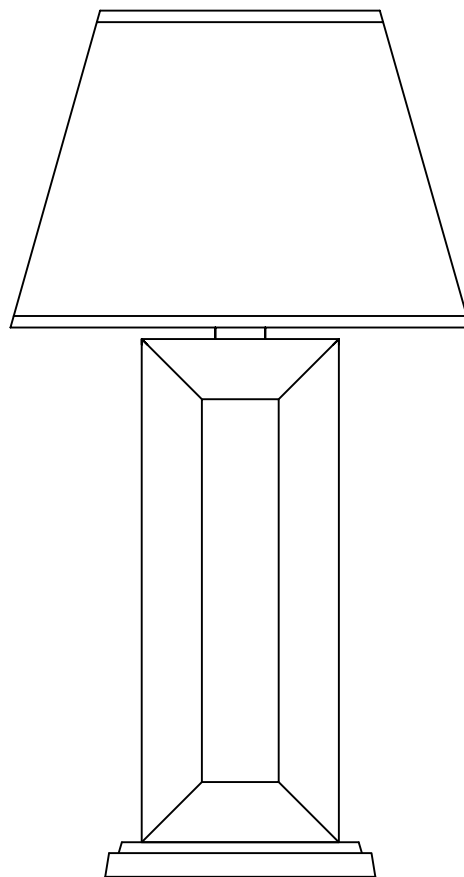

Above image represents many lamps,
your lamp may vary in style.

Questions, problems, missing parts? Before returning to the store,
call Kenroy Home Customer Service
8 a.m.-6 p.m., EST, Monday-Friday

904-642-4340

THANK YOU

We appreciate the trust and confidence you have placed in Kenroy Home through the purchase of this lamp.
We strive to continually create quality products designed to enhance your home.
Thank you for choosing us!

Table of Contents

Safety Information	2
Warranty	2
Pre-Installation	3
Planning Installation	3
Package Contents	3
Assembly	4, 5, 6
Care and Cleaning	7
Troubleshooting	7

Safety Information

- Consult a qualified electrician with any electrical questions you may have.



IMPORTANT: Inspect the wire insulation for any cuts, abrasions, or exposed copper that may have occurred during shipping. If there is a defect in the wire, do not continue the assembly process. Please call our Customer Service Team at 904-642-4340.

Warranty

1-YEAR LIMITED WARRANTY

WHAT IS COVERED

The manufacturer warrants this lamp to be free from defects in the materials and workmanship for a period of one (1) year from date of purchase. This warranty applies only to the original consumer purchaser and only to products used in normal use. If this product is found to be defective, the manufacturer's only obligation, and your exclusive remedy, is the repair or replacement of the product at the manufacturer's discretion, provided that the product has not been damaged through misuse, abuse, accident, modifications, alterations, neglect or mishandling. This warranty shall not apply to any product that is found to have been improperly installed, assembled, or used in any way not in accordance with the instructions supplied with the product. This warranty shall not apply to a failure of the product as a result of an accident, misuse, abuse, negligence, alteration, faulty installation, or any other failure not relating to faulty material or workmanship.

WHAT IS NOT COVERED

This warranty shall not apply to the finish on any portion of the product due to weathering, as this is considered normal wear. The manufacturer does not warrant and specifically disclaims any warranty, whether expressed or implied, other than the warranty contained herein. The manufacturer specifically disclaims any liability and shall not be liable for any consequential or incidental loss or damage, including but not limited to, any labor or expense costs involved in the replacement or repair of the product.

Contact the Customer Service Team at 904-642-4340.

Pre-Installation

PLANNING INSTALLATION

Read all instructions before assembly.

To avoid damaging this product, assemble it on a soft, non-abrasive surface such as carpet or cardboard. Inspect each part for defects that may have occurred during shipping.

Keep your receipt and these instructions for proof of purchase.



NOTE: This lamp requires the use of one 120V, 60HZ, 100-watt max, medium-base type A bulb (not included). Do not exceed the recommended wattage.

PACKAGE CONTENTS

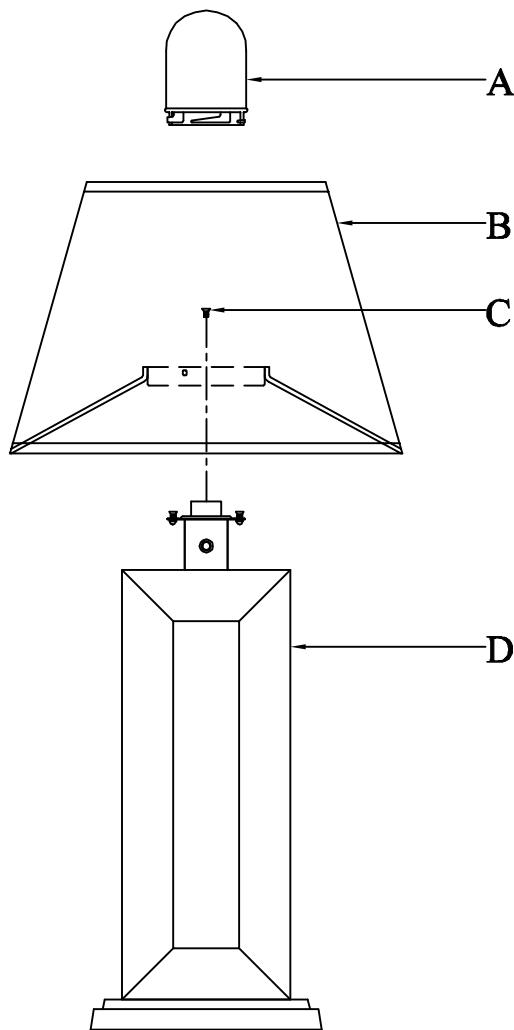

Part	Description	Quantity
A	Glass dome	1
B	Shade	1
C	Screw	3
D	Lamp body	1

Assembly instructions

1. Unpack the lamp and assemble shade

- Carefully organize and place all parts on a smooth, flat surface. line up all of the parts according to the assembly diagram.
- Insert the two screws (C) on top of cup into the two keyholes in glass dome holder and twist the shade counter-clockwise.
- Secure the shade (B) to the cup with a screw (C), then tighten the other (2) screws (C).

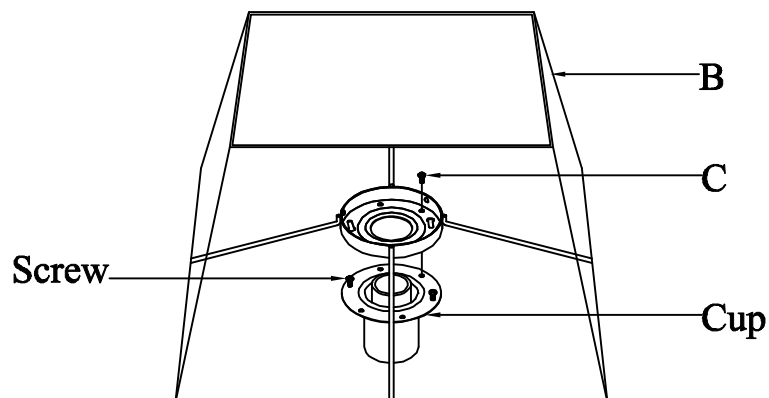
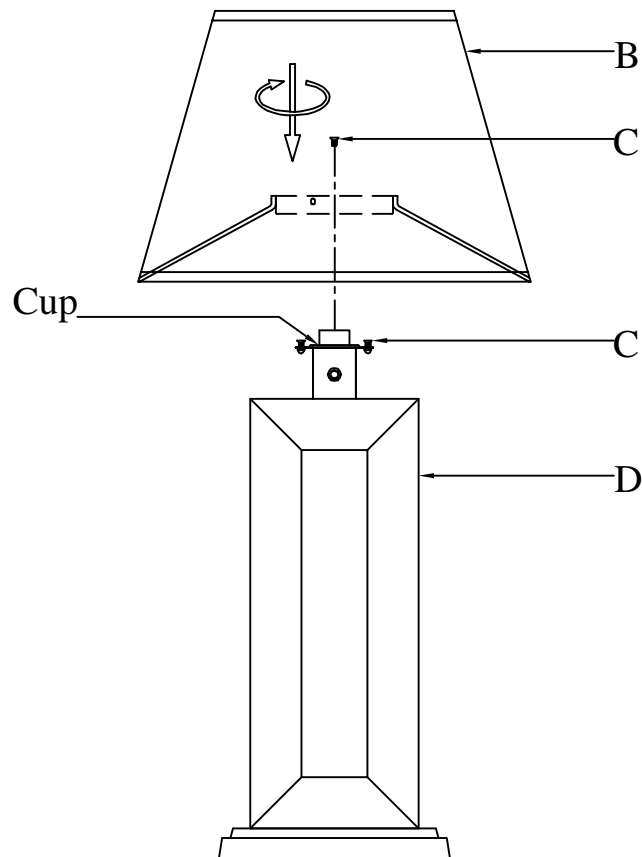

Assembly instructions (continued)

2. Install the bulb

- Prior to installing the bulb, inspect socket for silica packet. If packet is present, then remove and throw away. Do not expose it to children or pets.
- Install the 120V, 60HZ, 100-watt max. medium-base type A bulb (not included) into the socket of the light lamp.

NOTE: If led bulb is used, the led bulb must be rated for damp locations and enclosed luminaires.

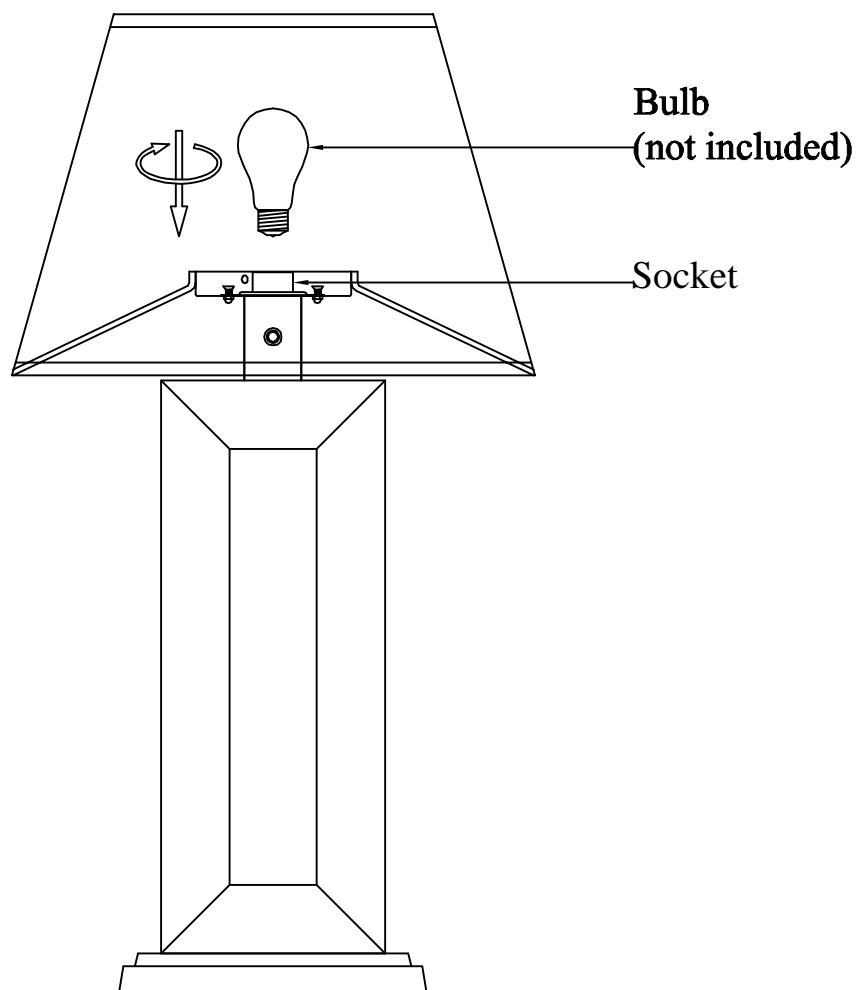

Assembly instructions (continued)

3. Assemble the glass dome

- Screw glass dome (A) to the glass dome holder.
- Plug cord into an outlet and push the switch to turn on the light.

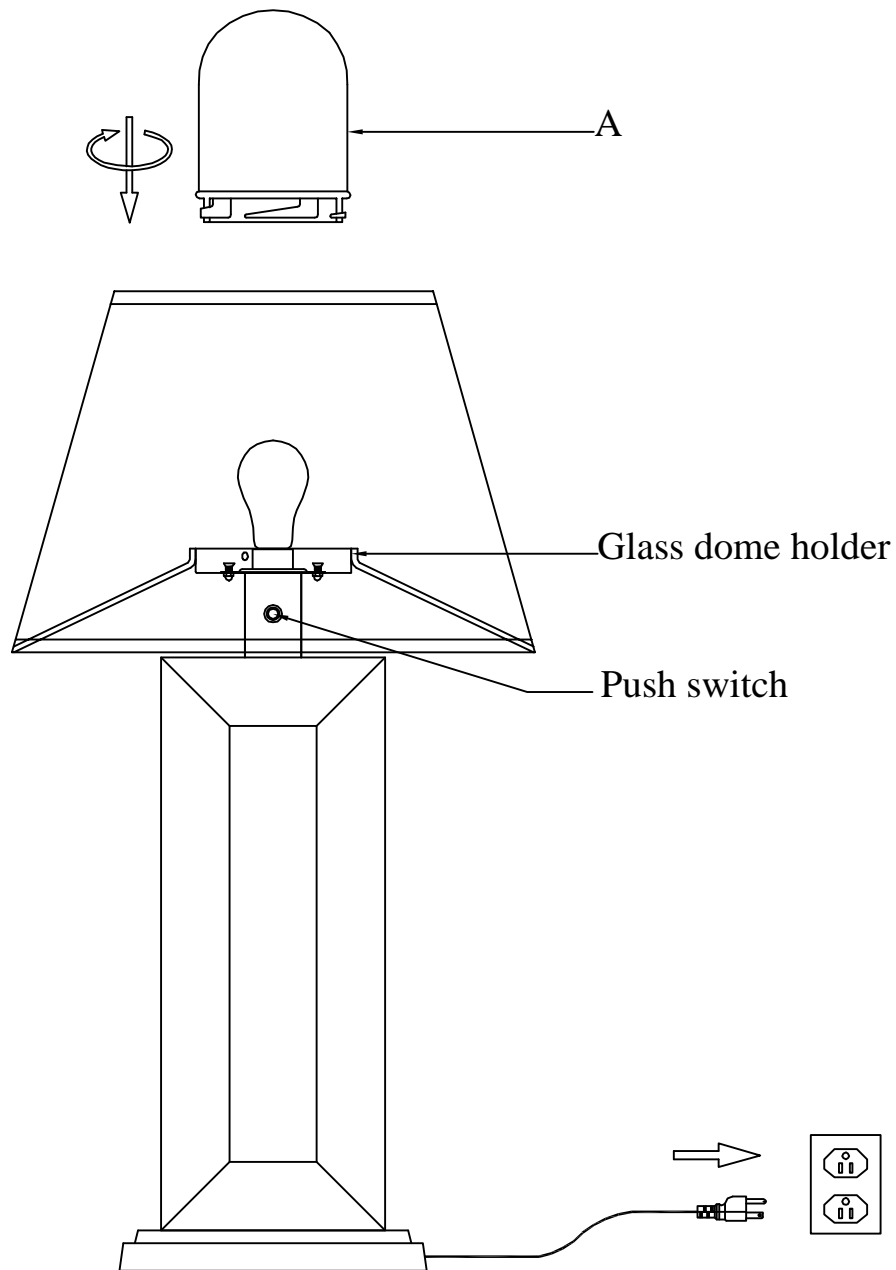

Important safety instructions

- Use only three-wire outdoor extension cords that have three-prong grounding plugs and grounding receptacles that accept the appliance's plug.
- Ground fault circuit interrupter (GFCI) protection is to be provided on the circuit or outlet to be used for the wet location portable luminaires. receptacles are available having built-in GFCI protection and are able to be used for this measure for this measure or safety.
- Use only with an extension cord for outdoor use. such as an extension cord of cord type sw, sw-a, sow, sow-a, stw, stw-a, stow, stow-a, sjw, sjw-a, sjow, sjow-a, sjtw, sjtw-a, or sjtow, sjtow-a.

NOTE: We recommend bringing in your lamp during winter.

Bulb Replacement

- Before replacing the bulb, be sure that the glass dome and bulb are cool and lamp is unplugged.
- Unscrew glass dome and existing bulb from socket, replace with a new bulb, then recover the glass dome, plug power supply cord back into outlet.

Care and Cleaning

- Clean the lamp with a soft, dry cloth. Do not use any cleaners with chemicals, solvents, or harsh abrasives.
- Wash the shade with a soft brush and mild detergent (such as dishwashing soap) and then thoroughly rinsed.

Troubleshooting

Problem	Possible Cause	Solution
The bulb will not light.	<input type="checkbox"/> The bulb is burned out.	<input type="checkbox"/> Replace the light bulb.
	<input type="checkbox"/> The power is off.	<input type="checkbox"/> Ensure that the power supply is turned on.
	<input type="checkbox"/> Did not insert plug into power outlet.	<input type="checkbox"/> Ensure that the plug is fully and properly inserted into the power outlet.
	<input type="checkbox"/> The circuit breaker is off.	<input type="checkbox"/> Ensure that the circuit breaker is set in the on position.
The fuse blows or a circuit breaker trips when the light is turned on.	<input type="checkbox"/> There is an exposed wire. <input type="checkbox"/> There are too many items on one circuit.	<input type="checkbox"/> Discontinue use of the lamp. <input type="checkbox"/> Contact a qualified electrician or call the Customer Service Team at 904-642-4340. <input type="checkbox"/> Unplug other items on the circuit.



ALL • TOGETHER • BETTER



www.kenroyhome.com

CUSTOMER SUPPORT TEAM

For any additional questions or concerns please contact our Customer Support Team:

 **904-642-4340**

 **@KenroyHome**

 **customerorders@kenroyhome.com**