

Model FD05R1/Z Parts list

A = Standard Equipment

O = Circuit Diagram

Item#	Part#	Description	Q'ty	Unit
001	126233-0	SPEED CHANGE LEVER ASSEMBLY	1	PC.
	C10 231433-0	COMPRESSION SPRING 4	2	PC.
002	183B50-3	HOUSING SET	1	
	C10 252126-6	HEX. LOCKING NUT M4-7	2	PC.
	D10	INC. 14		
003	851H34-2	FD05 NAME PLATE	1	
004	266429-2	TAPPING SCREW 3X16	9	PC.
005	232239-9	LEAF SPRING	1	PC.
006	456039-5	F/R CHANGE LEVER	1	
007	632F43-6	SWITCH UNIT	1	
	C10 620463-0	LED CIRCUIT	1	
008	644813-5	TERMINAL	1	
009	251451-2	- PAN HEAD SCREW M5X22	1	PC.
010	763228-8	KEYLESS DRILL CHUCK 10	1	
011	123503-8	GEAR ASS'Y	1	
012	629169-7	DC MOTOR	1	
013	911003-8	PAN HEAD SCREW M3X6	2	PC.
014	183B50-3	HOUSING SET	1	
	C10 252126-6	HEX. LOCKING NUT M4-7	2	PC.
	D10	INC. 2		
A01	251314-2	+ SCREW M4X12	1	PC.
A02	346909-5	HOOK	1	
A04	456128-6	BATTERY COVER	1	(FD05R1)
A05	***DC10WD	DC10WD BATTERY CHARGER	1	(FD05R1)
A06	BL1021B	BATTERY BL1021B	2	(FD05R1)
A07	821661-1	PLASTIC CARRYING CASE	1	(FD05R1)
	C10 417724-5	LATCH	2	PC. (FD05R1)

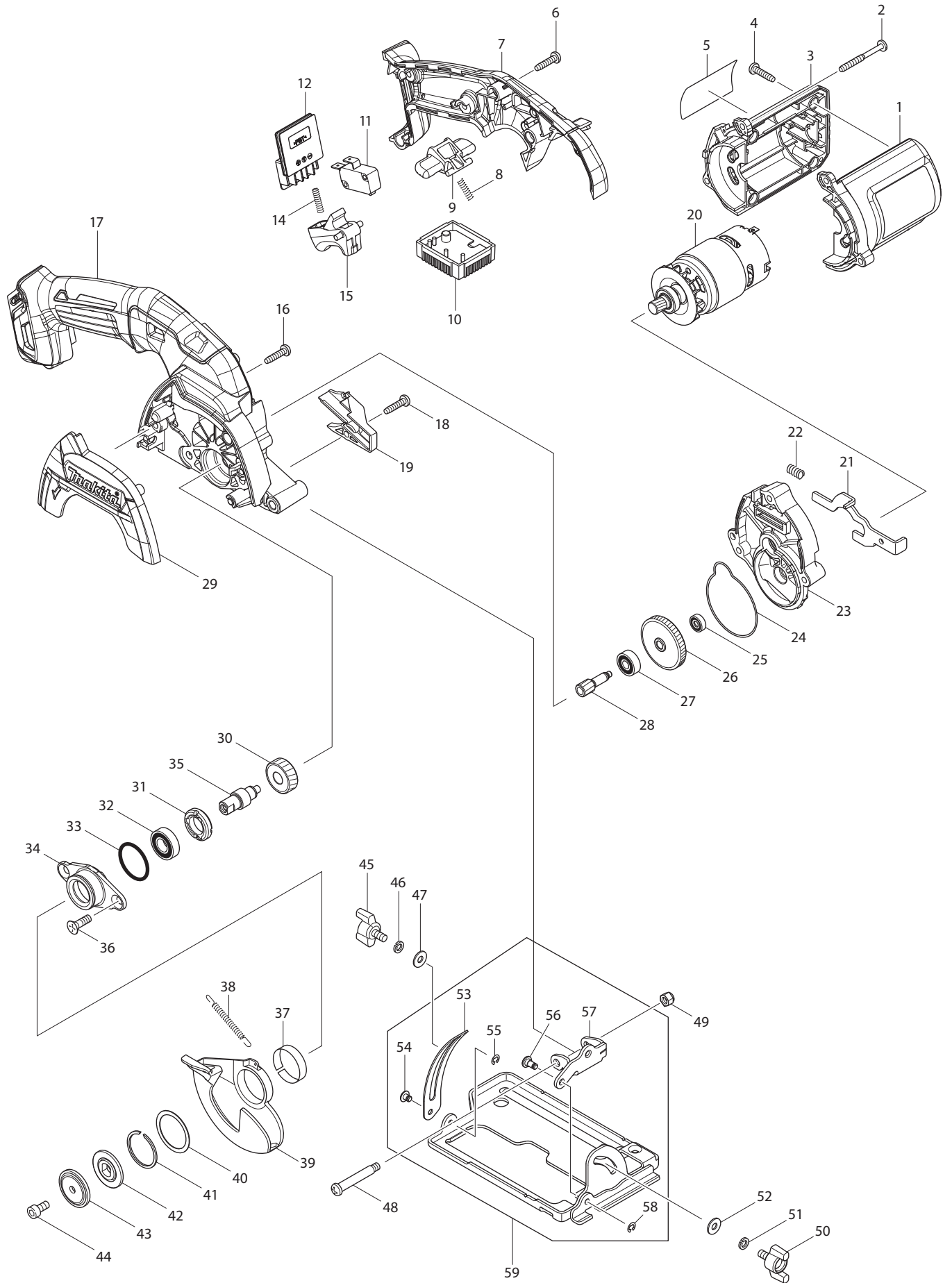

Model SH02 R1/Z Parts List

A = Standard Equipment

O = Circuit Diagram

Item#	Part#	Description	Q'ty	Unit
001	183C85-0	MOTOR HOUSING SET	1	
	C10 807M91-8	CAUTION LABEL	1	
	D10	INC. 3		
002	266560-4	TAPPING SCREW 4X40	3	PC.
003	183C85-0	MOTOR HOUSING SET	1	
	C10 807M91-8	CAUTION LABEL	1	
	D10	INC. 1		
004	265995-6	TAPPING SCREW 4X18	4	PC.
005	851M07-5	SH02 NAME PLATE	1	
006	265995-6	TAPPING SCREW 4X18	6	PC.
007	183C54-1	HANDLE SET	1	
	C10 263002-9	RUBBER PIN 4	3	PC.
	C20 263005-3	RUBBER PIN 6	1	PC.
	C30 931102-0	HEX. NUT M4	1	PC.
	C40 931202-6	HEX. NUT M5	3	PC.
	D10	INC. 17		
008	231469-9	COMPRESSION SPRING 4	1	PC.
009	419664-3	LOCK OFF LEVER	1	PC.
010	632F84-2	CONTROLLER UNIT	1	
011	650577-1	SWITCH SD-006-BB2AA-AA	1	PC.
012	644813-5	TERMINAL	1	
014	231469-9	COMPRESSION SPRING 4	1	PC.
015	419665-1	SWITCH LEVER	1	PC.
016	265995-6	TAPPING SCREW 4X18	2	PC.
017	183C54-1	HANDLE SET	1	
	C10 263002-9	RUBBER PIN 4	3	PC.
	C20 263005-3	RUBBER PIN 6	1	PC.
	C30 931102-0	HEX. NUT M4	1	PC.
	C40 931202-6	HEX. NUT M5	3	PC.
	D10	INC. 7		
018	265995-6	TAPPING SCREW 4X18	1	PC.
019	452234-5	DUCT	1	PC.
020	629885-1	DC MOTOR	1	PC.
021	346337-4	SHAFT LOCK	1	PC.
022	233117-6	COMPRESSION SPRING 6	1	PC.
023	140625-9	GEAR HOUSING COMPLETE	1	PC.
	C10 213325-5	O RING 19	1	PC.
024	424358-7	PACKING	1	PC.
025	210036-3	BALL BEARING 604ZZ	1	PC.
026	227737-6	HELICAL GEAR 47	1	PC.
027	210028-2	BALL BEARING 606ZZ	1	PC.
028	227735-0	HELICAL GEAR 9B	1	PC.
029	456252-5	BLADE COVER	1	
030	227736-8	HERICAL GEAR 28	1	PC.
031	285847-5	BEARING RETAINER 14-23	1	PC.
032	210069-8	BALL BEARING 6900DDW	1	PC.
033	213435-8	O RING 26	1	PC.
034	318660-7	BEARING BOX	1	PC.
035	325983-6	SPINDLE	1	PC.

036	265034-2	+ COUNTERSUNK HEAD SCREW M5X16	2 PC.
037	345470-9	THICKNESS RING	1 PC.
038	231867-7	TENSION SPRING 4	1 PC.
039	452236-1	SAFETY COVER	1 PC.
040	267127-1	FLAT WASHER 26	1 PC.
041	257938-2	RETAINING RING(EXT) WR-26	1 PC.
042	224435-3	INNER FLANGE 28	1 PC.
043	224177-9	OUTER FLANGE 28	1 PC.
044	922212-4	HEX. SOCKET HEAD BOLT M5X12	1 PC.
045	265760-3	THUMB SCREW M5X10	1 PC.
046	942101-7	SPRING WASHER 5	1 PC.
047	941101-4	FLAT WASHER 5	1 PC.
048	265056-2	+ PAN HEAD SCREW M5	1 PC.
049	252103-8	HEX. LOCK NUT M5-8	1 PC.
050	265760-3	THUMB SCREW M5X10	1 PC.
051	942101-7	SPRING WASHER 5	1 PC.
052	941101-4	FLAT WASHER 5	1 PC.
053	346338-2	DEPTH GUIDE	1 PC.
054	268004-0	PIN 4	1 PC.
055	961017-7	STOP RING E-3	1 PC.
056	268028-6	PIN 5	1 PC.
057	346339-0	ANGULAR GUIDE	1 PC.
058	961017-7	STOP RING E-3	1 PC.
059	135416-1	BASE ASSEMBLY	1 PC.
	D10	INC. 53-58	
A01	783202-0	HEX. WRENCH 4	1 PC.
A02	A-95021	T.C.T. SAW BLADE 85X15X20T	1 PC.
A03	456128-6	BATTERY COVER	1 (SH02R1)
A04	***DC10WD	DC10WD BATTERY CHARGER	1 (SH02R1)
A05	BL1021B	BATTERY BL1021B SET (197414-3)	2 (SH02R1)
A06	821663-7	PLASTIC CARRYING CASE	1 (SH02R1)
	C10	LATCH	2 PC.
D01	654208-4	RECEPTACLE	1 PC.
D02	654207-6	RECEPTACLE	1 PC.