

LED CEILING/ CANOPY

SPEC SHEET



Suitable for
Wet Locations



Catalog No. : HEL50-4K-BZ

Type : Garage/Canopy

Project Name :

Location :

Qty :

Date :

Covering the same footprint as traditional HID garage and canopy lights but with the benefits from the latest in LED technology to save 85% on energy bills, lasts over 50,000-hour and doesn't require any bulb changes. Its hands-free installation feature makes the fixture easy to mount and comes fully gasketed and water-tight for outdoor and indoor installation. Dimmable LED fixture.

APPLICATIONS

Its bright 5297 Lumens makes it ideal for large entry-ways, parking areas, covered walkways, storage areas and loading docks.

PRODUCT PERFORMANCE AT A GLANCE

SYSTEM WATTAGE	LED WATTAGE	LUMENS	LPW	CRI	REPLACES (MH)
50W	45W	5297 lm	105 lm/w	≥80	150W

HOUSING

Die cast aluminum housing with UV-stabilized vandal-resistant polycarbonate prismatic lens.

OPTICS

Wide Type V coverage with even distribution provides inviting security lighting.

FINISH

Fade, weather, and abrasion resistant, electrostatically applied, thermally cured, triglycidal isocyanurate (TGIC) textured polyester powdercoat finish. Paint is bronze.

IP RATING & LISTINGS

LED light engine is weather proof rated IP66.

DLC 4.2, cULus, FCC Certified

MOUNTING

Fits to any standard junction box or direct to any surface via detachable mounting plate. Included hook for hands-free installation while making electrical connections. Also includes multiple 1/2-in conduit entry plugs.

WARRANTY

Fixture is covered by a 5-year limited warranty. See probrite.com/warranty for details.

PRODUCT LINE DRAWING

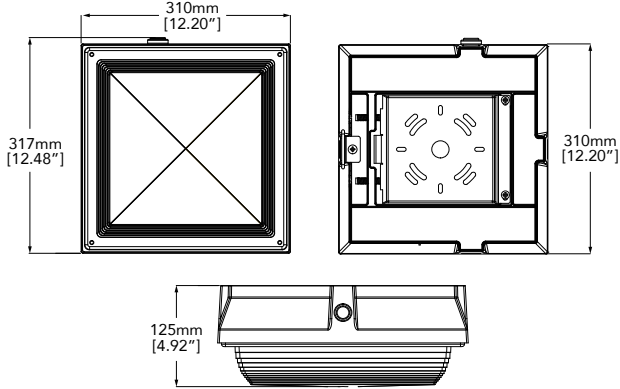

SUGGESTED MOUNTING HEIGHT:
8-15FT. (2.4-2.6M)

2D PHOTOMETRIC VIEW

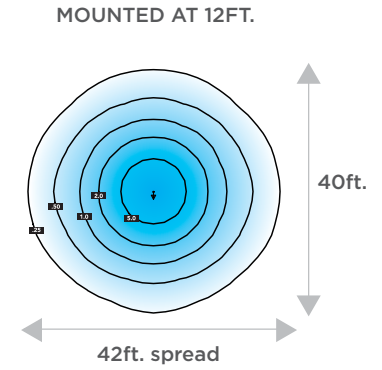

PRODUCT SPECIFICATIONS

Product Dimensions	: 12.48" x 12.2" x 4.92"
Weight	: 7.05
Lumens	: 5297
System Wattage	: 50W
LED Wattage	: 45W
Efficacy	: 105
CRI	: 80
Replaces (MH)	: 150W
Mounting	: Ceiling mount
Frequency	: 50-60Hz
THD(Total Harmonic Distortion)	: <20%
PF(Power Factor)	: >0.9
Ambient Operating Temperature	: (-30) - 40°C
Input Voltage	: 120-277V
LED Chip	: LUXEON 3030 2D
Photocell	: No
Driver	: 0-10V Dimming
Standard Lifetime	: L70 >50,000hrs
Standard Warranty	: 5 Years
Water Proofing Grade	: IP66
CCT	: 4000K
Certifications	: DLC, UL/cUL

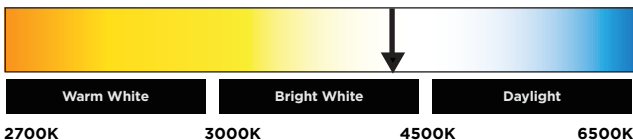

APPLICATION

