

W Walker[®]
Edison
furniture company

Item # : W58BDSD

Ítem N.º: W58BDSD

Assembly Instructions

Instrucciones de ensamblaje

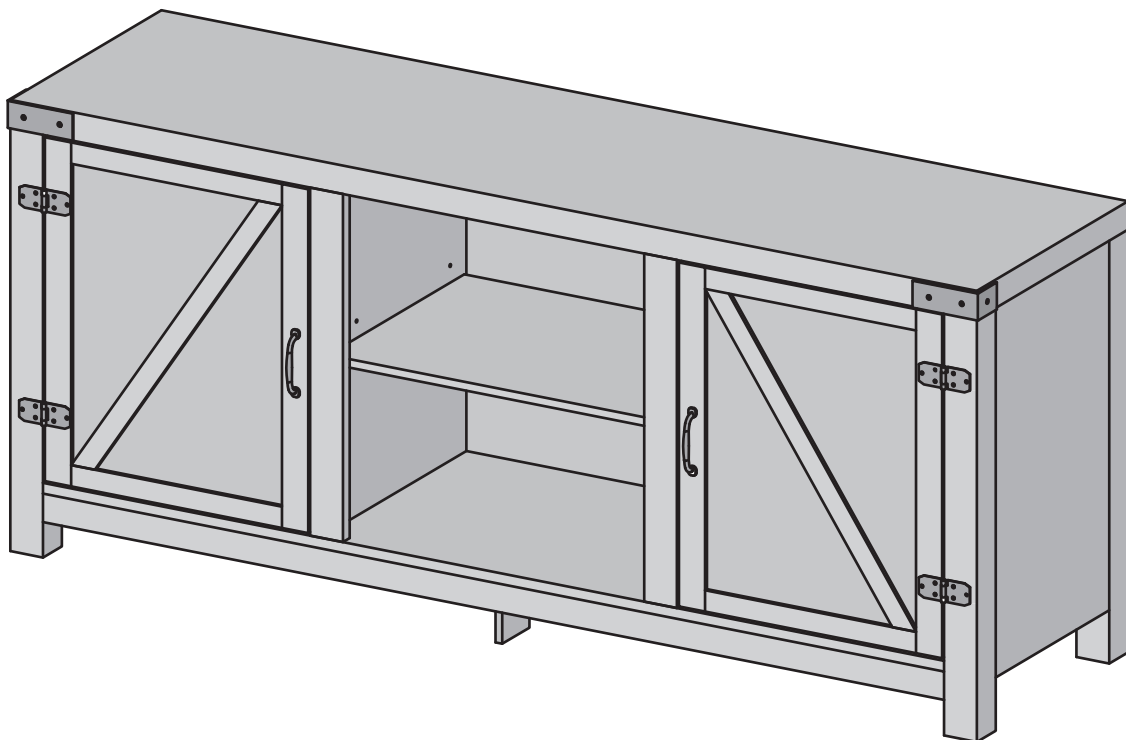

For the most current instructions, additional assembly tips, to report damage or request parts, please visit our website at www.walkerredison.com.

Visite nuestro sitio web para obtener las instrucciones más actualizadas, sugerencias de montaje e informes de daños, o para solicitar piezas. www.walkerredison.com

Revised 04/03/2018

General Assembly Guidelines

Instructions de montage générales

- I. Ensure that all parts and hardware are available before beginning assembly.
I. Asegúrese de tener a disposición todas las piezas y materiales antes de comenzar el ensamblaje.
- II. Follow each step carefully to ensure the proper assembly of this product.
II. Siga todos los pasos con atención para garantizar el ensamblaje correcto de este producto.
- III. Two people are recommended for ease in the assembly of this product.
III. Para un ensamblaje sencillo de este producto se recomienda que participen dos personas.
- IV. The three main types of hardware used to assemble this product are : wood dowels , screws and bolts.
IV. Los tres tipos principales de materiales utilizados para ensamblar este producto son: clavijas de madera, tornillos y pernos.
- V. The provided glue is to secure wood dowels in place . When first inserting dowels , locate the appropriate hole for the dowel , place a small amount of glue in the hole and insert the dowel . Wipe away excess glue immediately.
V. El pegamento proporcionado es para asegurar las clavijas de madera en su lugar. Cuando inserte las clavijas por primera vez, ubique el orificio apropiado para ellas, coloque una pequeña cantidad de pegamento en el orificio e insértelas. Limpie el exceso de pegamento de inmediato.

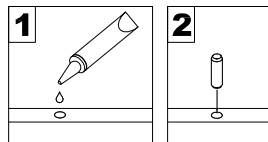

In future assembly steps when dowels are necessary to attach assembly parts together , place a small amount of glue on the end of the dowel before attaching parts together . Wipe away excess glue immediately.

En los siguientes pasos de ensamblaje donde sea necesario utilizar clavijas para unir distintas piezas, coloque una pequeña cantidad de pegamento en la punta de la clavija antes de unir las piezas. Limpie el exceso de pegamento de inmediato.

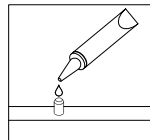

- VI. A Phillips head screwdriver is required for the assembly of this product .
VI. Para ensamblar este producto, es necesario un destornillador de cabeza tipo Phillips.

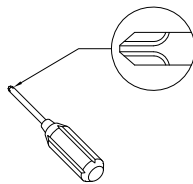

- VII. Power tools should not be used to assemble this product .
VII. No se deben utilizar herramientas eléctricas para ensamblar este producto.

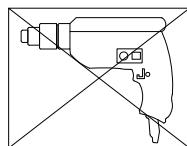





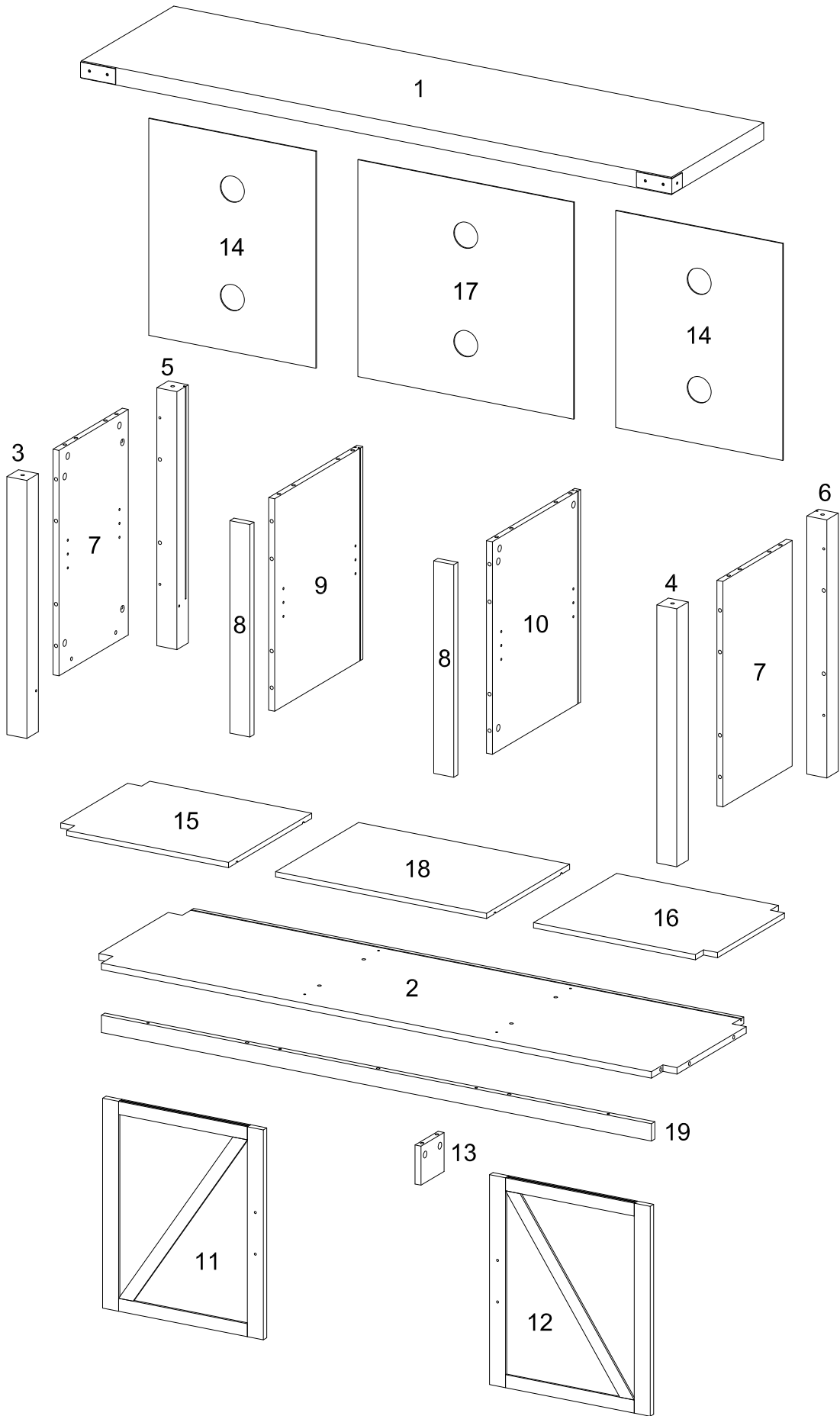



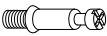

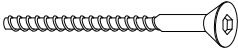



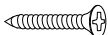

Parts List

Lista de materiales

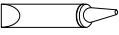

Hardware List

| | | | | |
|---|---|-----------|--|--------|
| A |  | Ø8x30mm | Wooden dowel clavija de madera | 31 pcs |
| B |  | | Cam bolt perno de leva | 26 pcs |
| C |  | Ø15x11mm | Cam lock levas de fijación | 26 pcs |
| D |  | Ø6x50mm | Bolt perno | 4 pcs |
| E |  | | Hinge bisagra | 4 pcs |
| F |  | Ø3x12mm | Screw tornillo | 24 pcs |
| G |  | | Handle manija | 2 pcs |
| H |  | Ø4x22mm | Bolt perno | 4 pcs |
| J |  | Ø8x5x16mm | Shelf support pin perno de soporte de estante | 12 pcs |
| K |  | | Plastic wedges cuñas de plástico | 12 pcs |
| L |  | Ø3x17mm | Screw tornillo | 12 pcs |
| M |  | 30x20mm | Metal piece pieza de metal | 2 pcs |
| N |  | Ø3x12mm | Screw tornillo | 2 pcs |
| P |  | | Door stopper tope de puerta | 2 pcs |
| Q |  | Ø3x15mm | Screw tornillo | 4 pcs |
| R |  | | Sticker etiqueta | 26 pcs |
| S |  | Ø4mm | Wrench llave inglesa | 1 pc |
| T |  | | Glue tube tubo de pegamento | 2 pcs |
| U |  | Ø4x45 | Screw tornillo | 4 pcs |

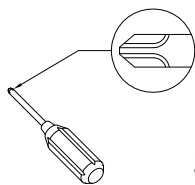

Philips head screwdriver required for assembly

(not included)

Se requiere un destornillador de cabeza Philips para el montaje

(no incluido)

The hardware quantities listed above are required for proper assembly.

Some extra hardware may also have been included.

Las cantidades de materiales antes mencionadas son necesarias para el ensamblaje apropiado.

Se podrían incluir algunas piezas de materiales adicionales.

Step 1

Paso 1

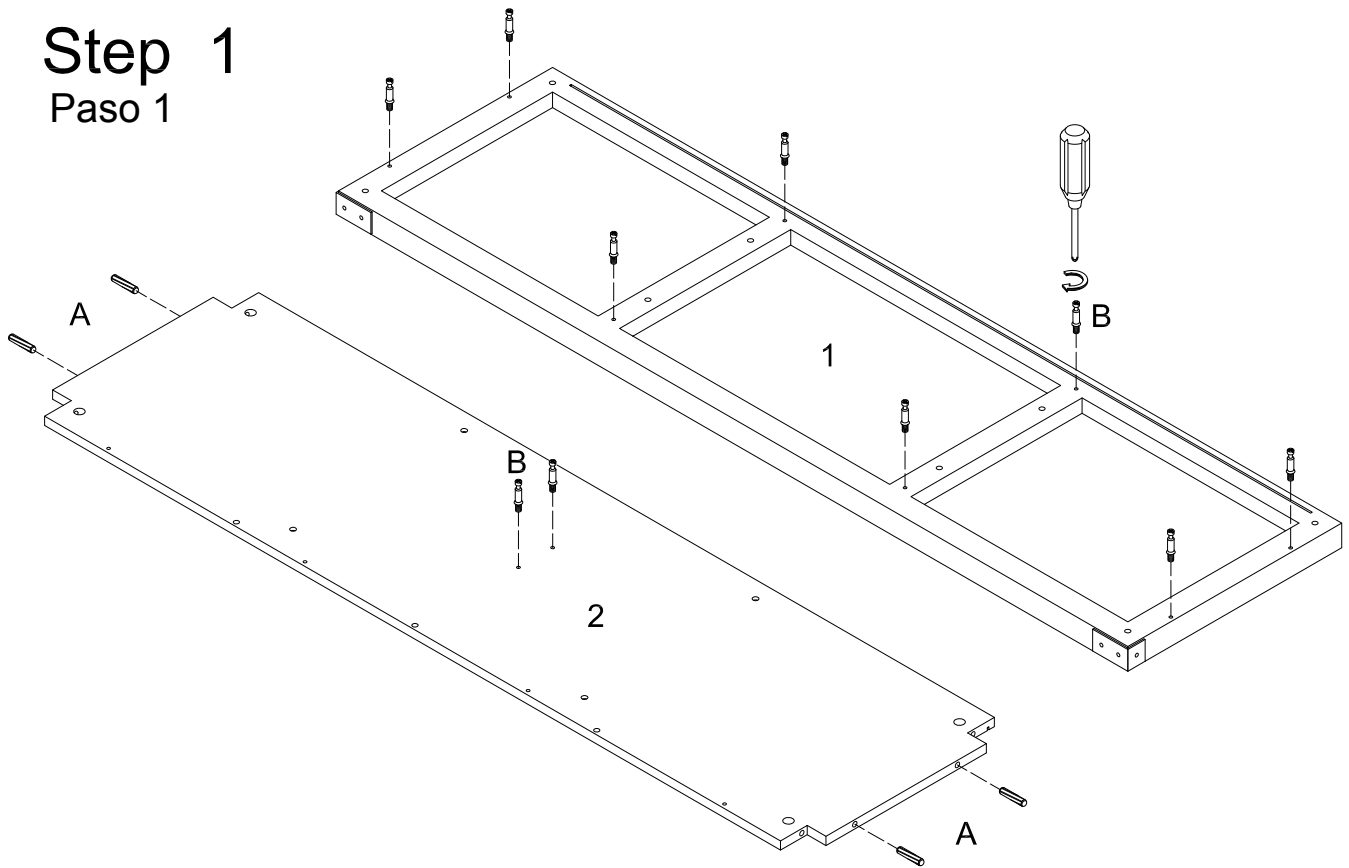

Attach cam bolts (B) to parts (1) and (2).

Fije los pernos de leva (B) a las piezas (1) y (2).

Step 2

Paso 2

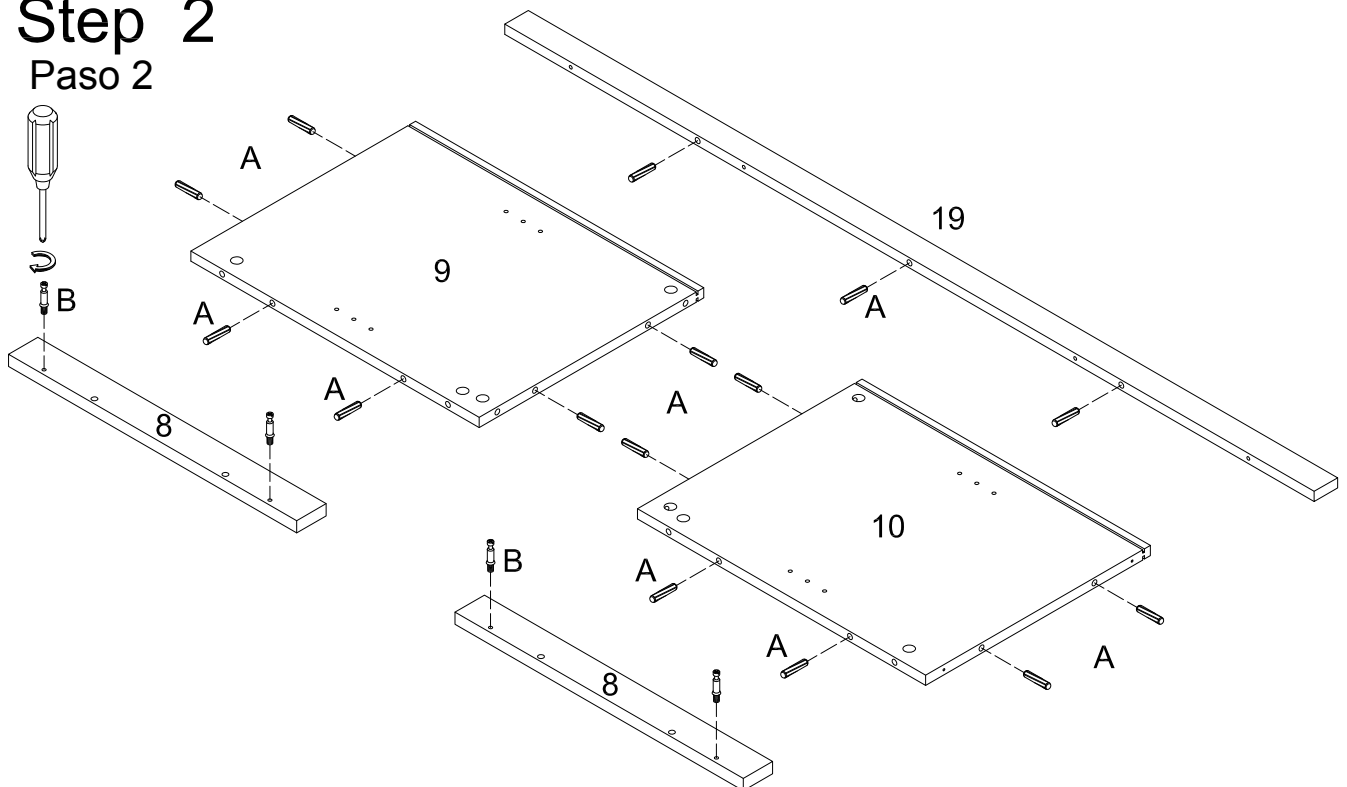

Attach cam bolts (B) to part (8). Insert wooden dowels (A) to parts (9, 10) and (19).

Fije los pernos de leva (B) a la pieza (8). Inserte las clavijas de madera (A) en las piezas (9, 10) y (19).

Step 3

Paso 3

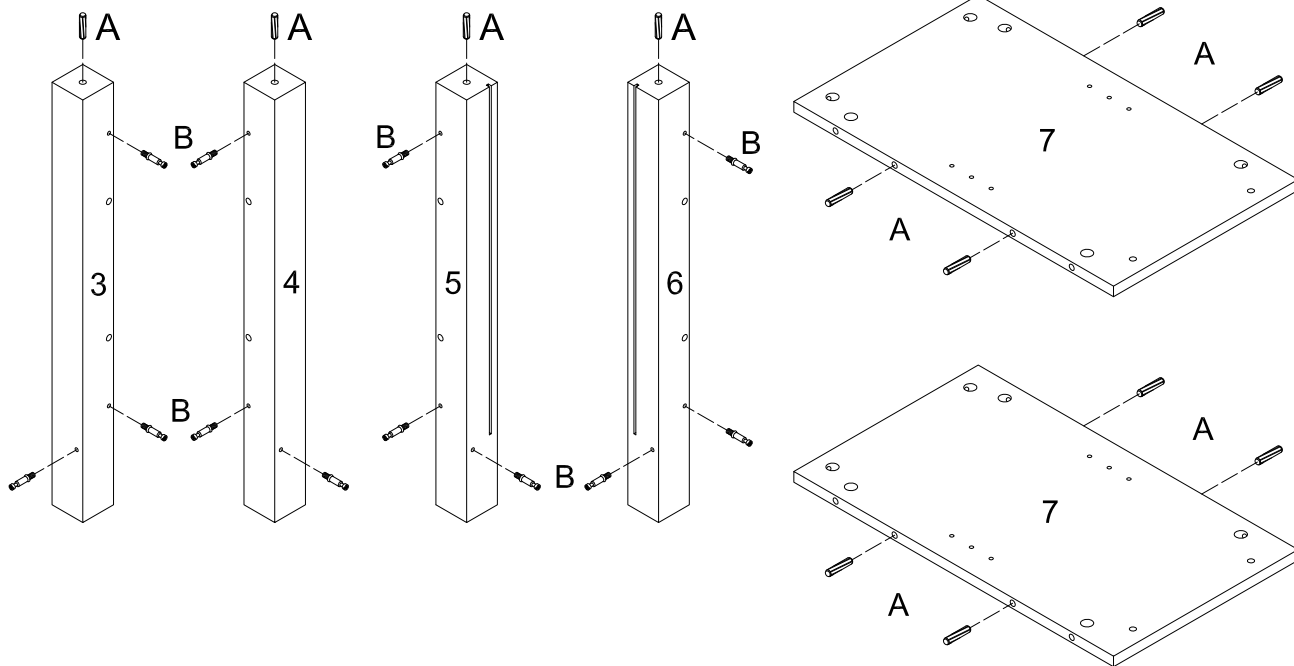

Insert wooden dowels (A) into designated areas in parts (3, 4, 5, 6) and (7). Attach cam bolts (B) to parts (3, 4, 5, 6).

Insert wooden dowels (A) into designated areas in parts (3, 4, 5, 6) and (7). Attach cam bolts (B) to parts (3, 4, 5, 6).

Step 4

Paso 4

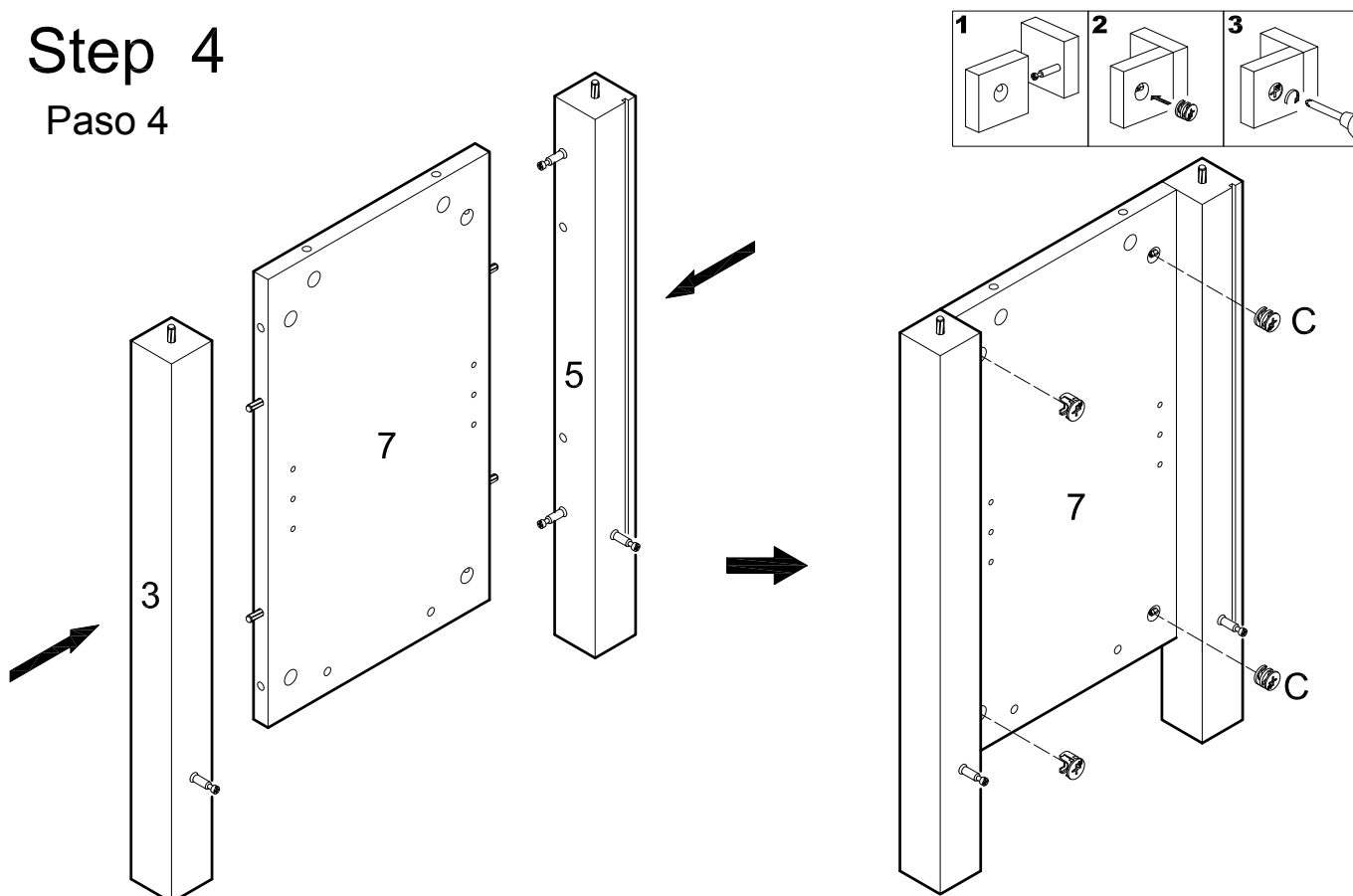

Attach parts (3) and (5) to part (7), and then attach cam locks (C) to fully assembled part (7).
Acople las piezas (3) y (5) a la pieza (7) y luego acople las levas de fijación (C) a la pieza completamente ensamblada (7).

Step 5

Paso 5

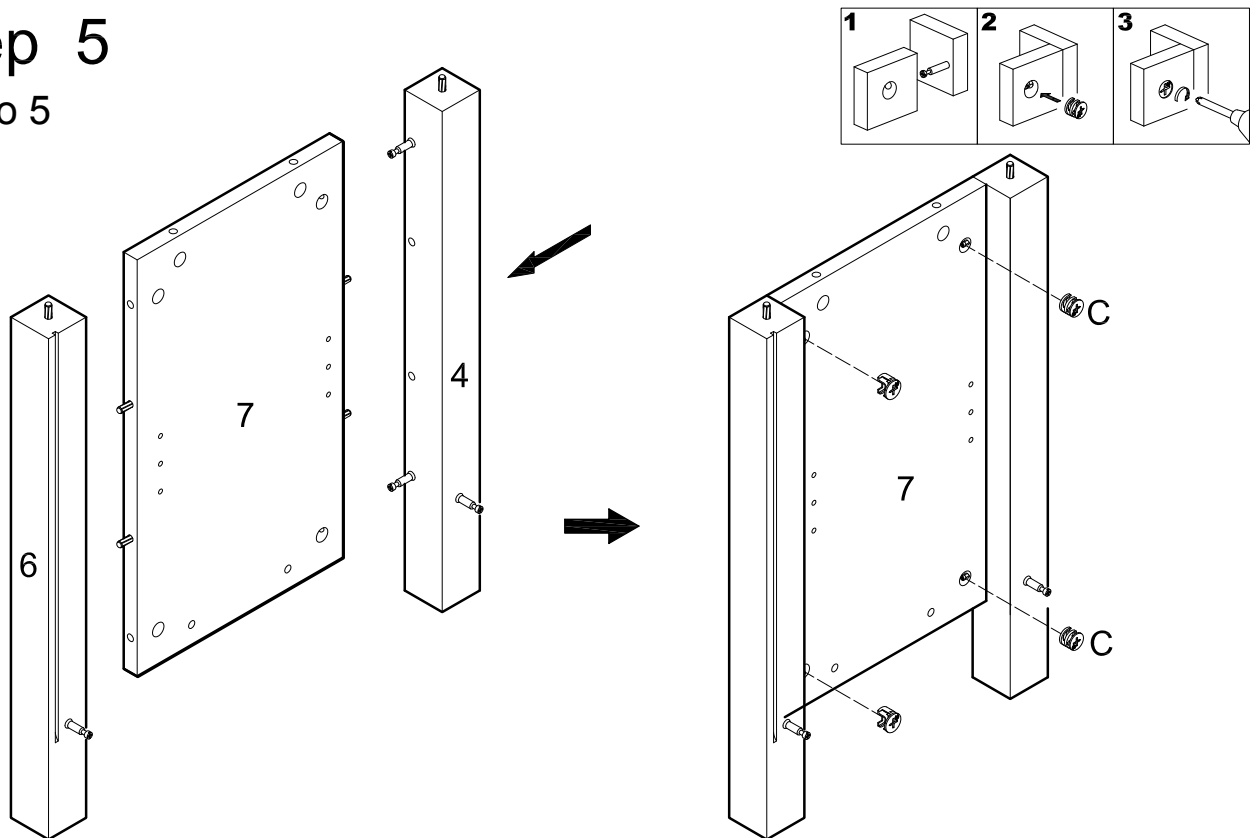

Attach parts (4) and (6) to the other part (7), and then insert cam locks (C) to the fully assembled part (7).

Acople las piezas (4) y (6) a la otra pieza (7) y luego inserte las levas de fijación (C) en la pieza completamente ensamblada (7).

Step 6

Paso 6

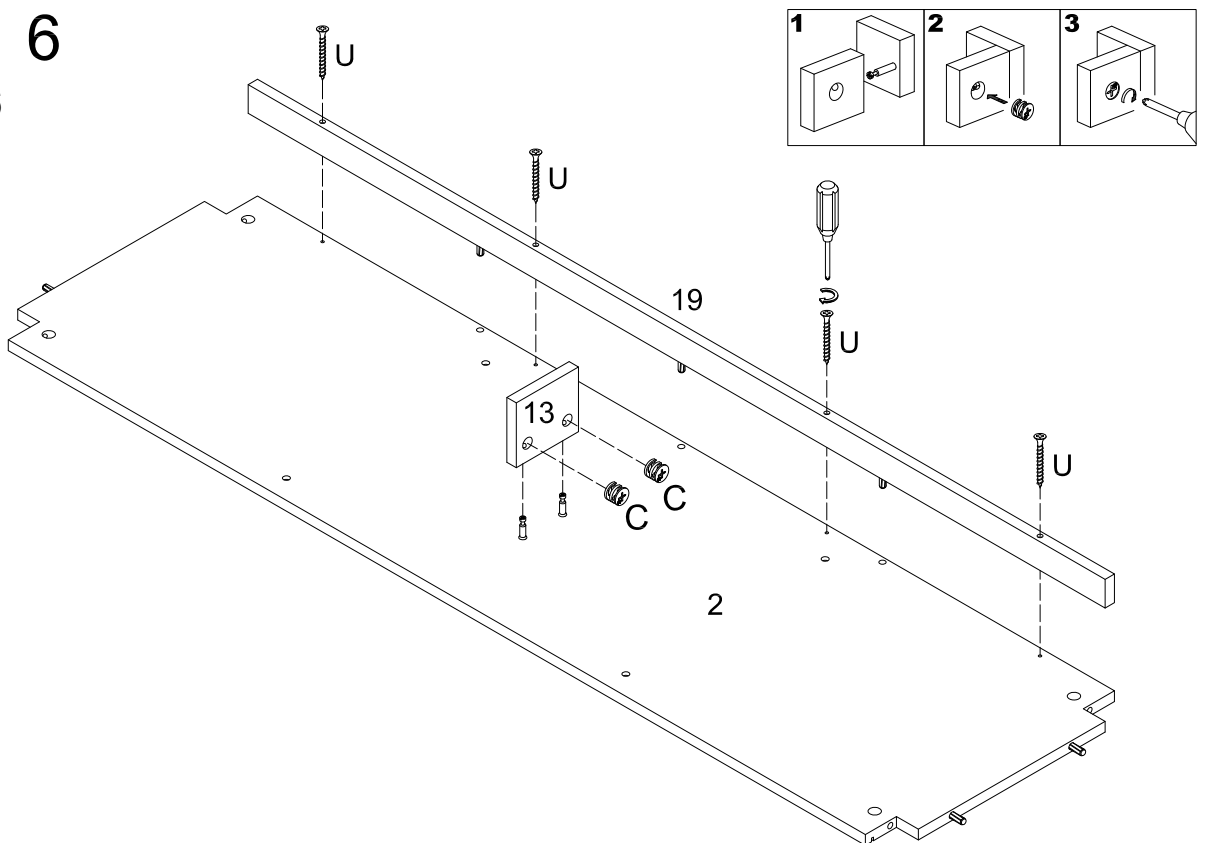

Attach cam locks (C) to parts (13) to panel (2). Attach slat (19) to panel (2) by using screw (U) as guides.

Acople las levas de fijación (C) a las piezas (13) del panel (2). Fije el listón (19) al panel (2) usando el tornillo (U) como guía.

Step 7

Paso 7

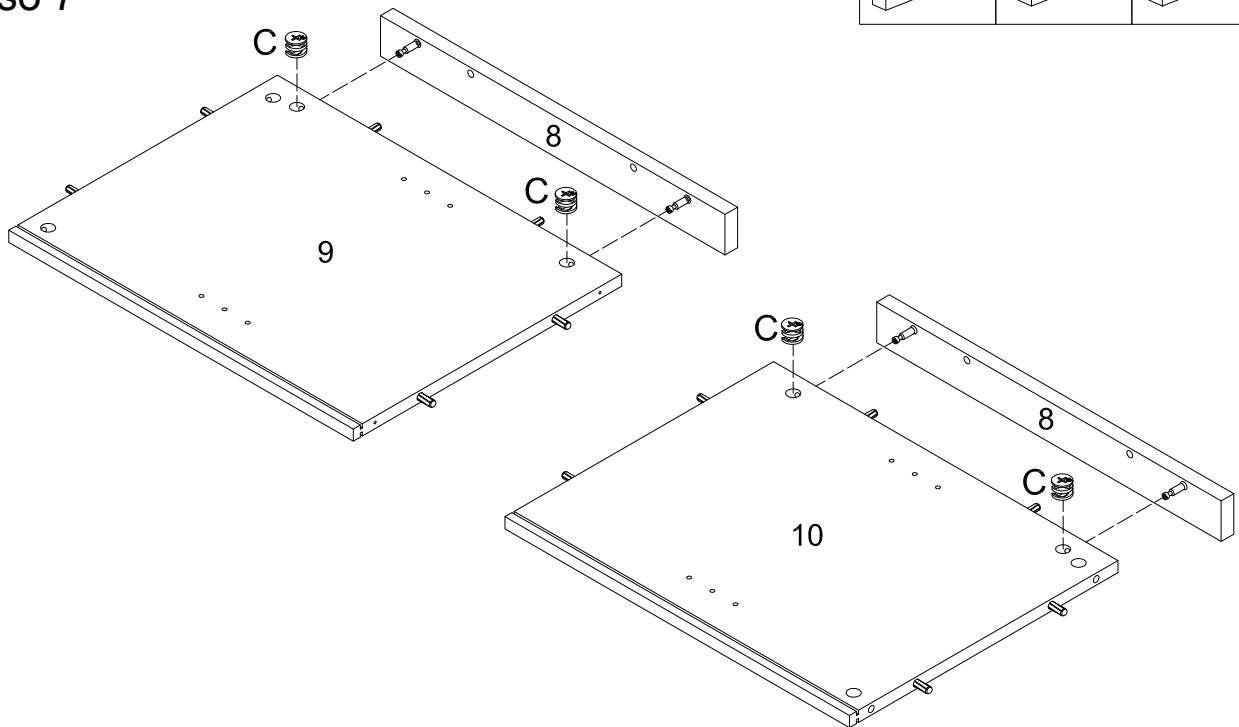
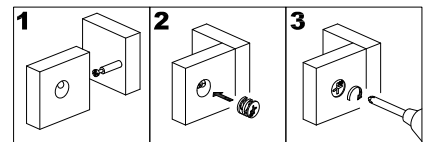

Attach cam locks (C) to part (9) to connect part (8), and to part (10) to connect to the other part (8).

Acople las levas de fijación (C) a la pieza (9) para conectar la pieza (8) y a la pieza (10) para conectar a la otra pieza (8).

Step 8

Paso 8

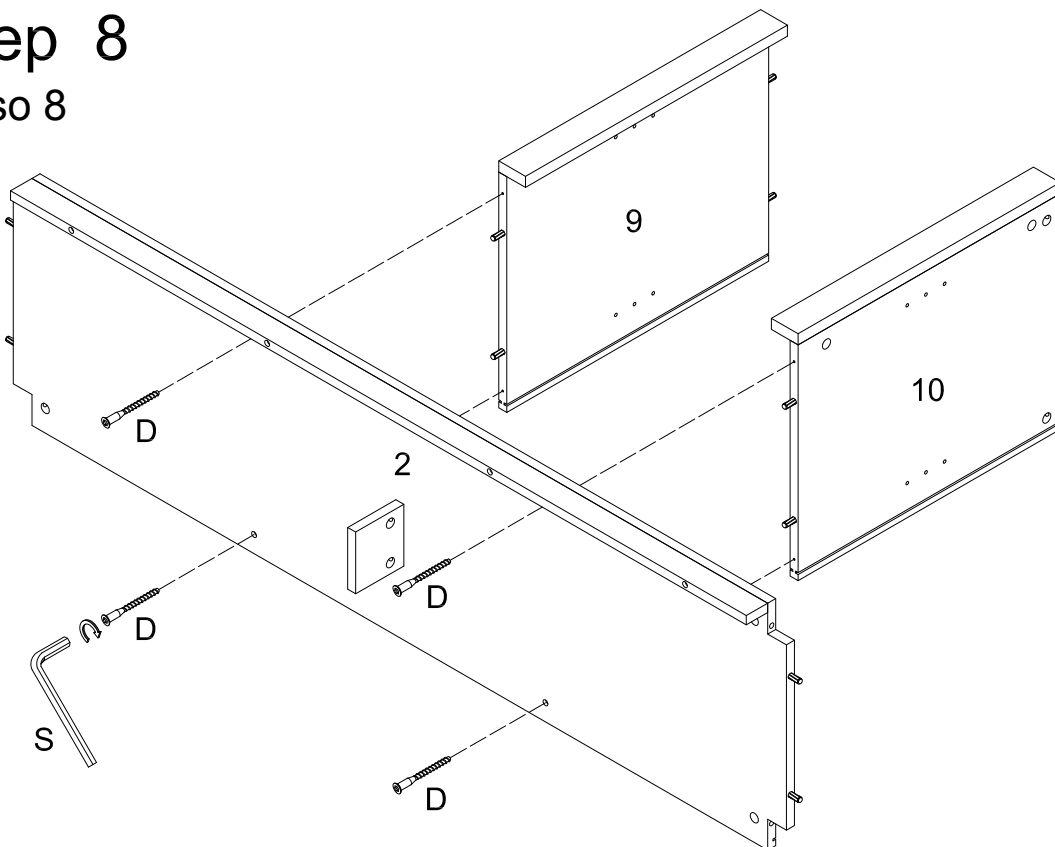

Use the wrench (S) to use bolts (D) to connect parts (9) and (10) to part (2).

Use la llave inglesa (S) para colocar los pernos (D) a fin de conectar las piezas (9) y (10) a la pieza (2).

Step 9

Paso 9

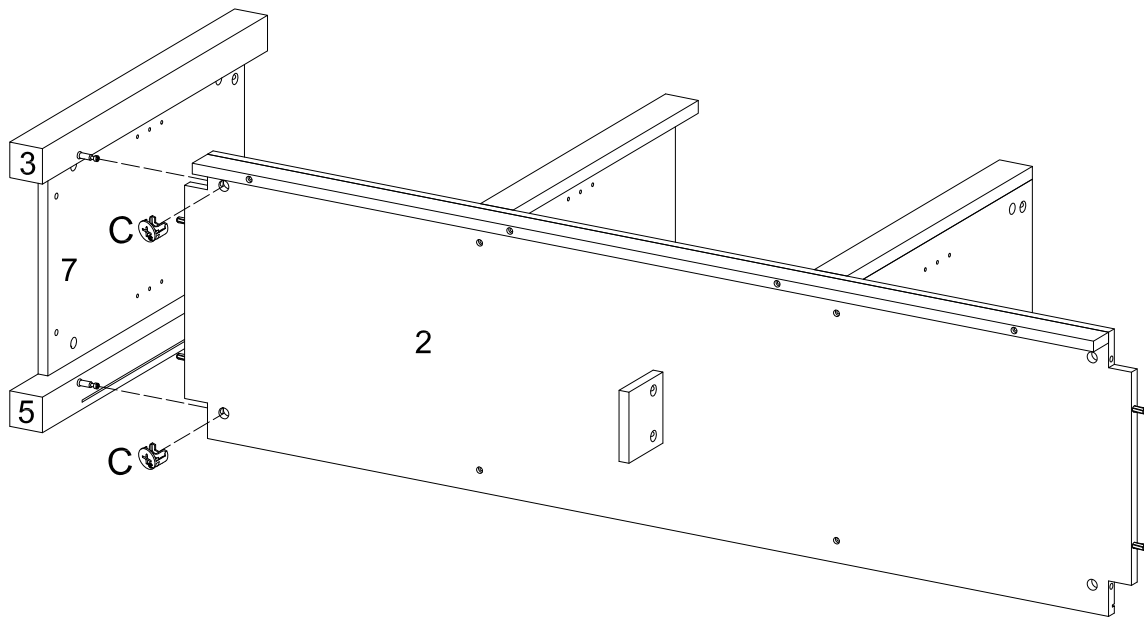
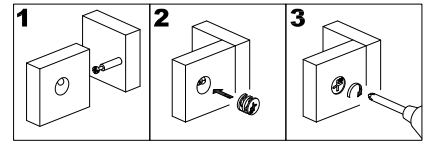

Use cam bolts (C) to connect parts (3) and (5) to part (2).

Use los pernos de leva (C) para conectar las piezas (3) y (5) a la pieza (2).

Step 10

Paso 10

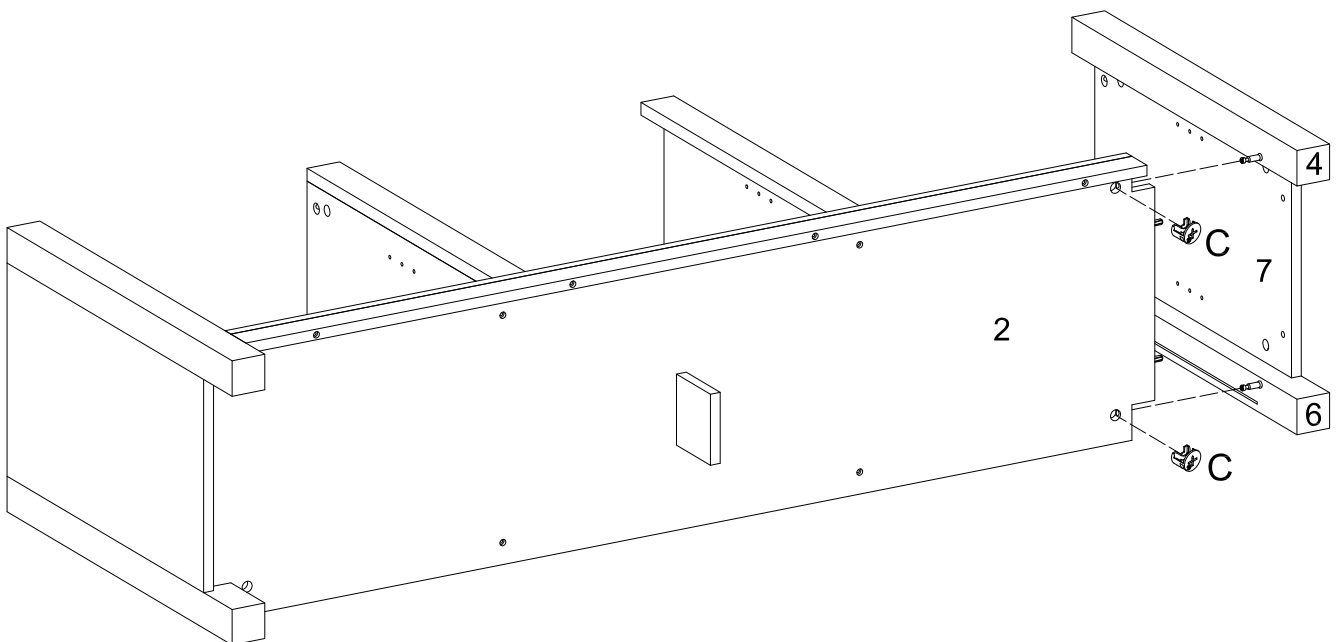
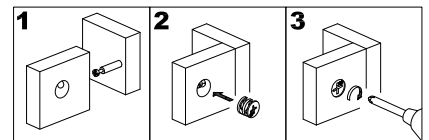

Use cam bolts (C) to connect parts (4) and (6) to part (2).

Use los pernos de leva (C) para conectar las piezas (4) y (6) a la pieza (2).

Step 11

Paso 11

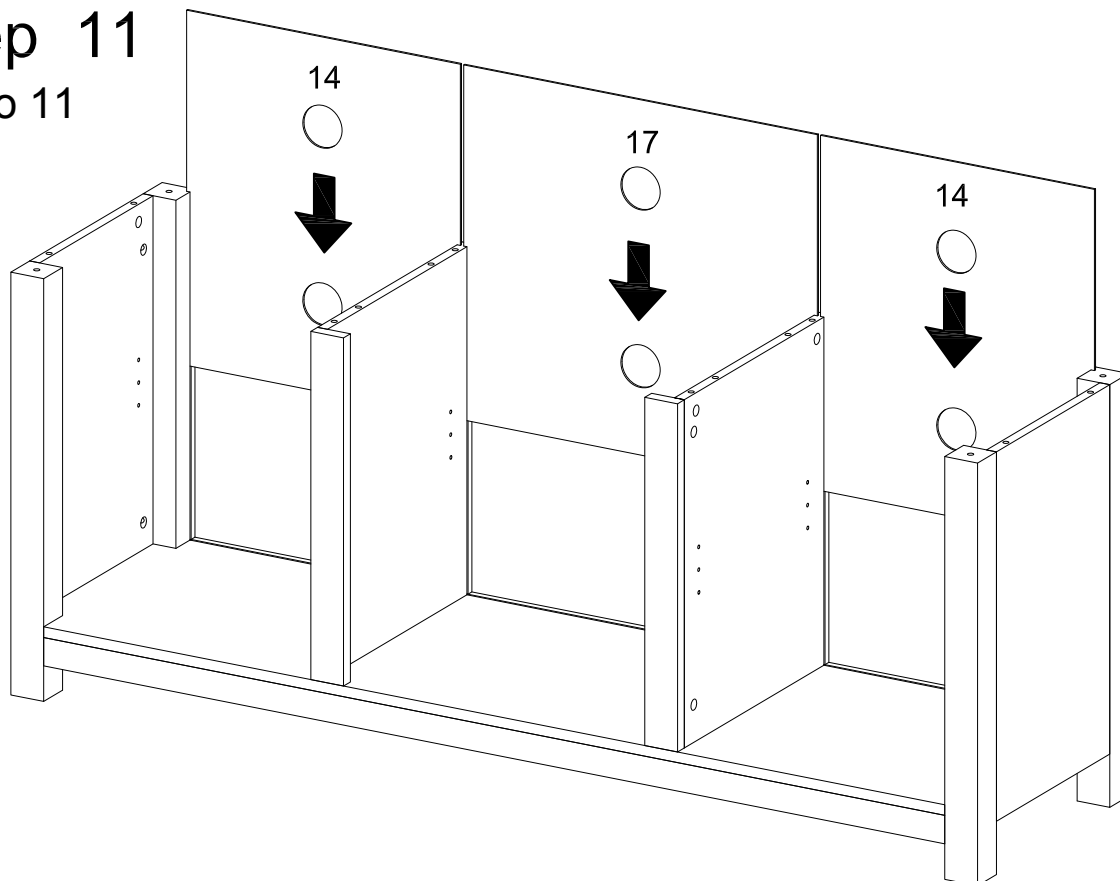

Slide parts (14) and (17) into designated area.

Deslice las piezas (14) y (17) hacia dentro del área designada.

Step 12

Paso 12

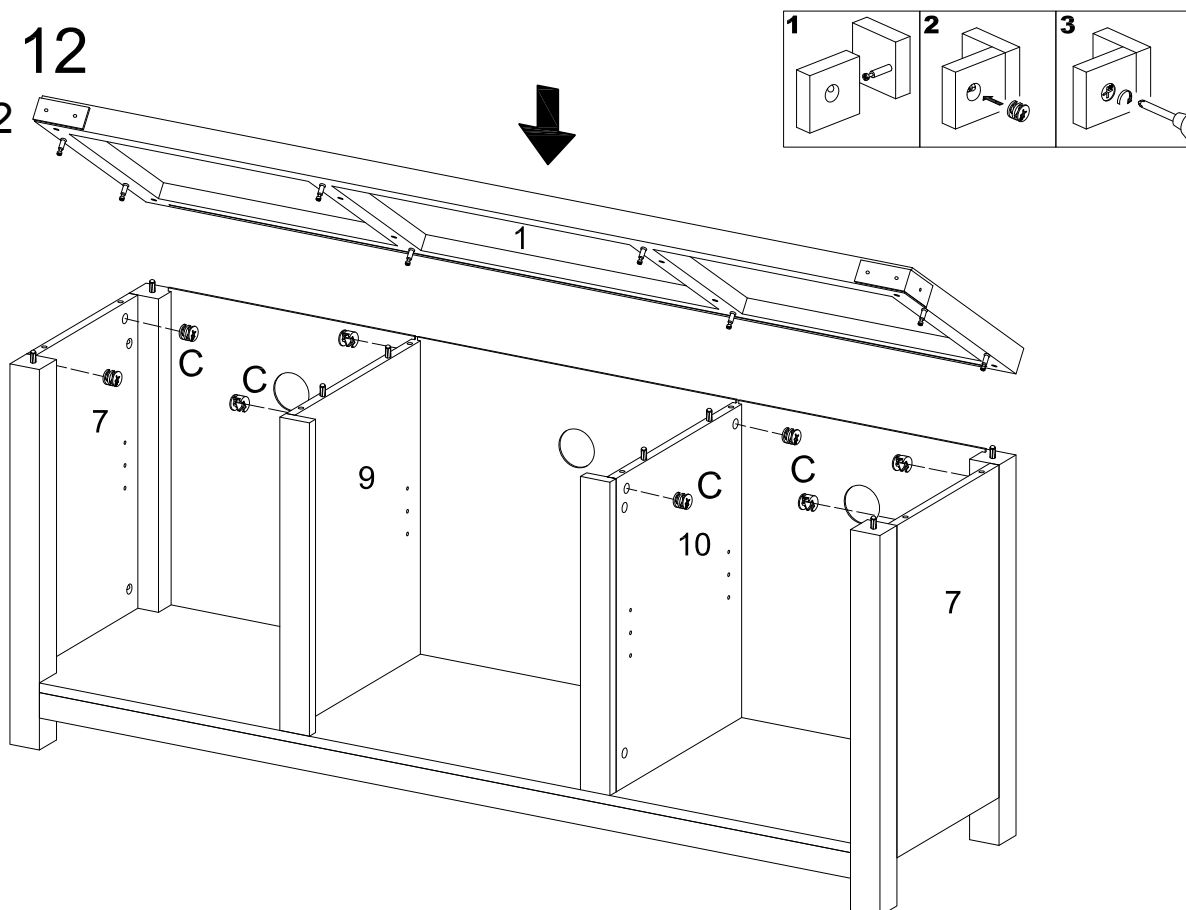

Use cam bolts to connect part (1) to the frame assembly as shown in the diagram.

Use pernos de leva para conectar la pieza (1) al ensamblaje del marco como se muestra en el diagrama.

Step 13

Paso 13

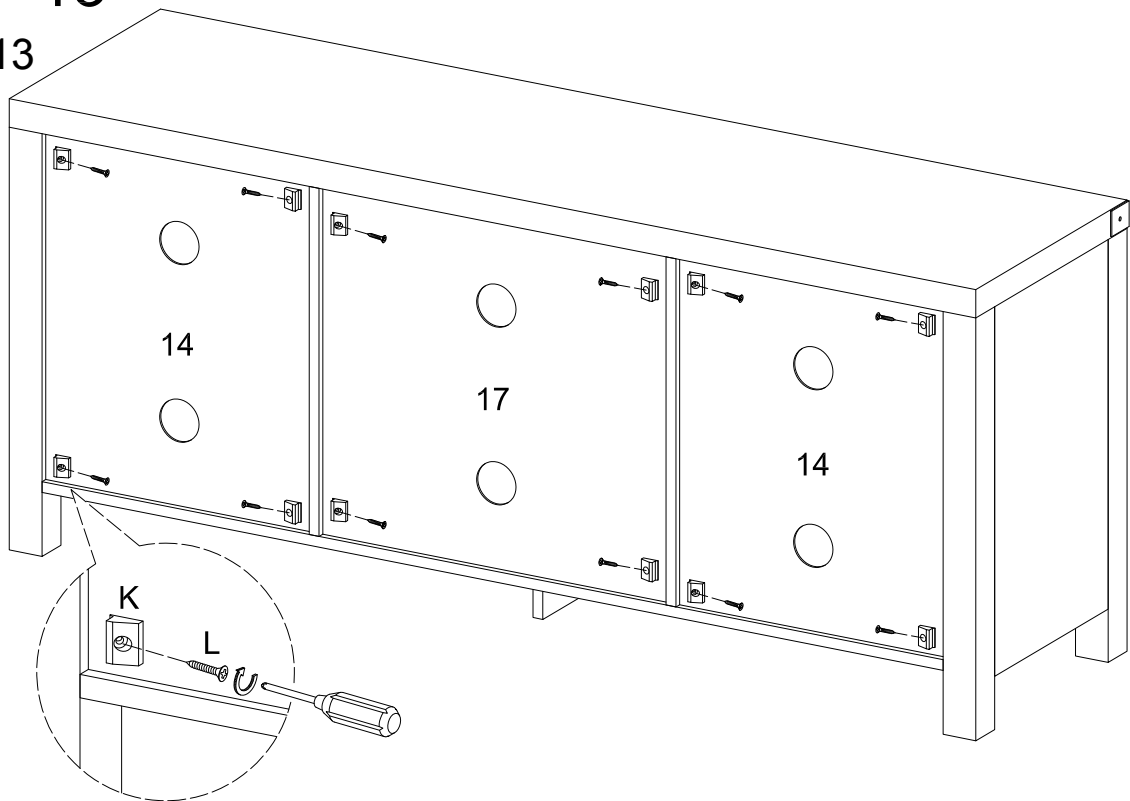

Attach the plastic wedges (K) by using the screws (L) as shown in the diagram.

Coloque las cuñas plásticas (K) utilizando los tornillos (L) como se muestra en el diagrama.

Step 14

Paso 14

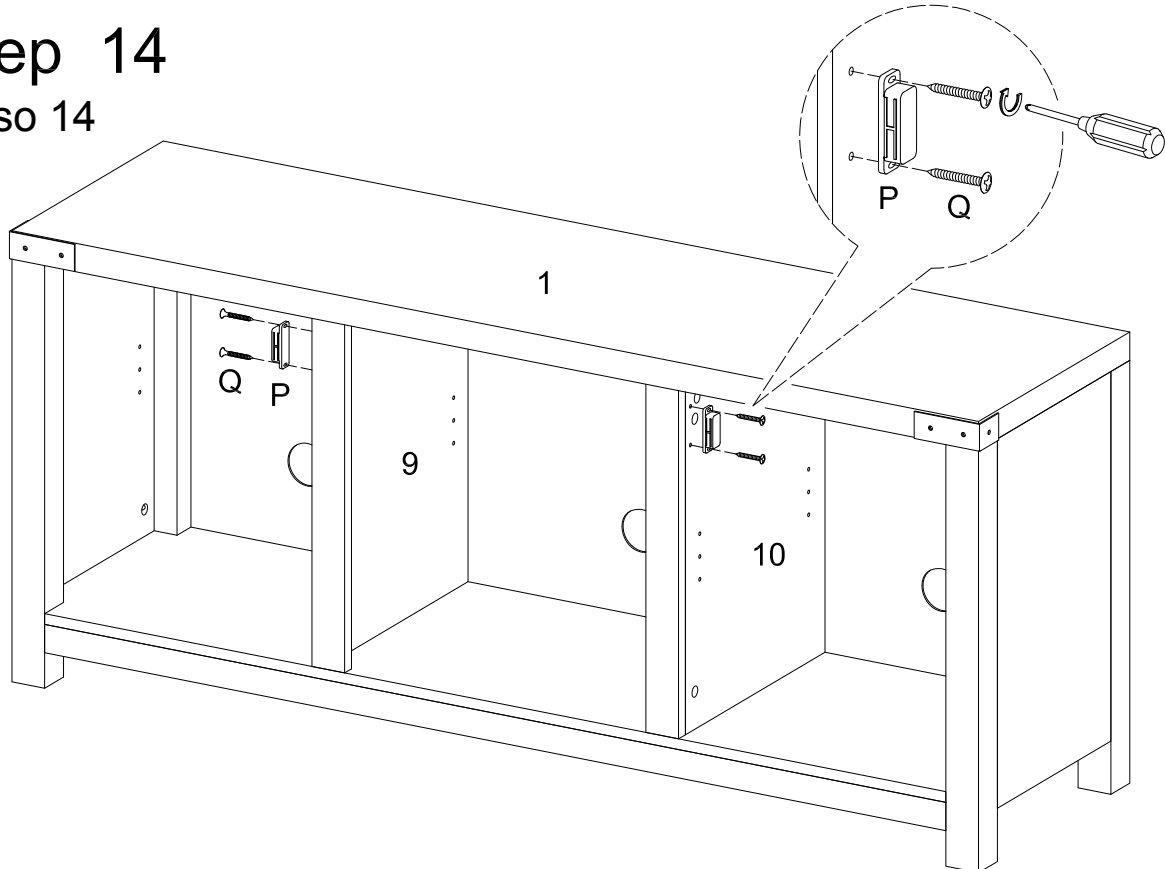

Attach door stopper (P) to designated areas by using screws (Q).

Fije el tope de la puerta (P) a las áreas designadas con los tornillos (Q).

Step 15

Paso 15

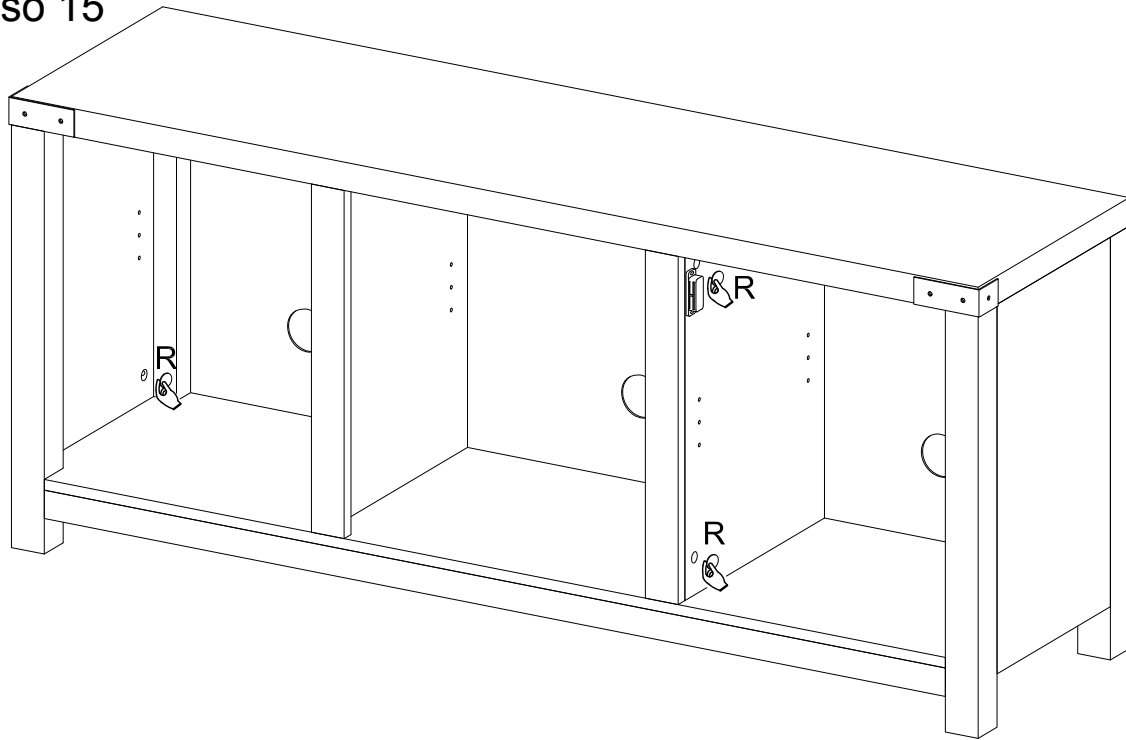

Place stickers (R) over cam locks as desired.

Coloque las etiquetas (R) sobre las levas de fijación según lo desee.

Step 16

Paso 16

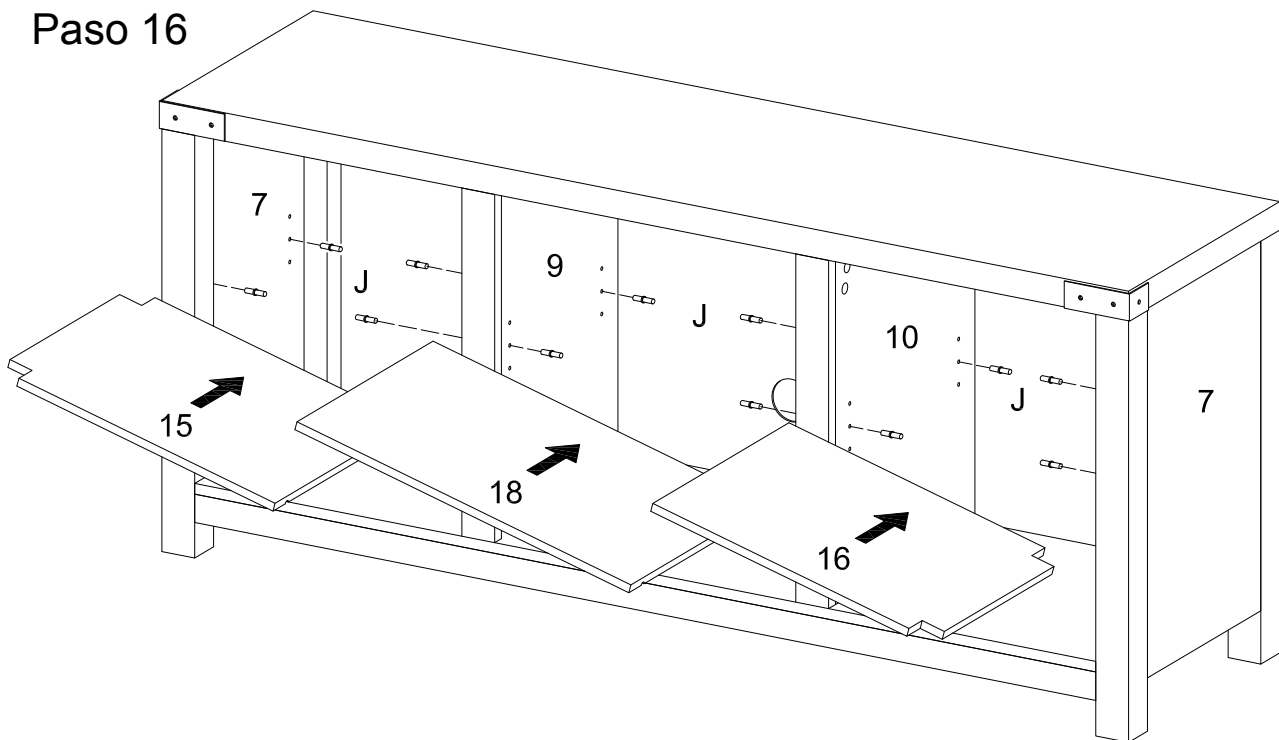

Insert shelf supports (J) and place shelves (15,16) and (18) as shown in the diagram.

Inserte los soportes para estantes (J) y coloque los estantes (15, 16) y (18) como se muestra en el diagrama.

Step 17

Paso 17

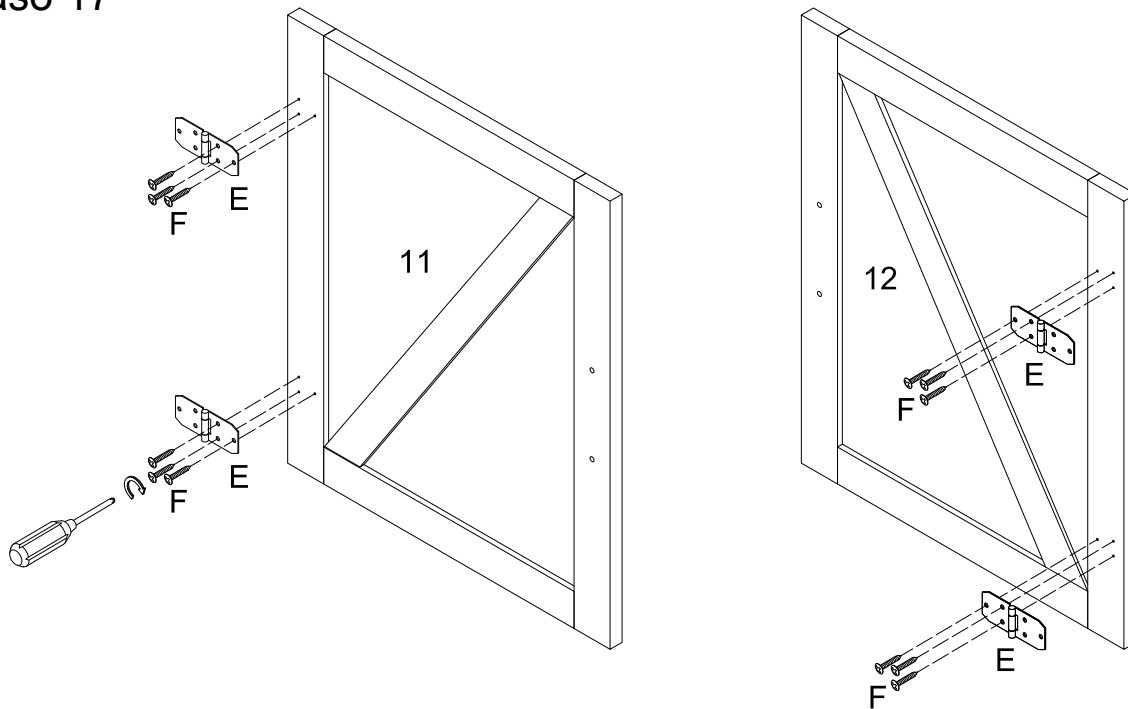

Attach hinges (E) to the doors (11,12) by using screws (F).
Fije las bisagras (E) a las puertas (11, 12) con los tornillos (F).

Step 18

Paso 18

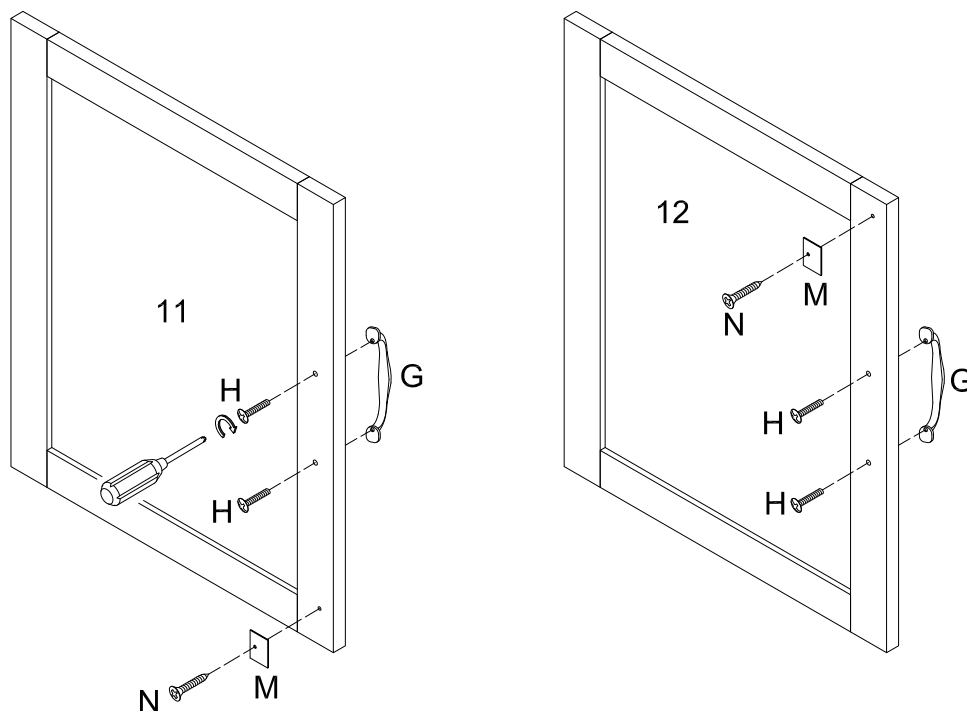

Attach handles (G) to the doors (11,12) by using screws (H). Attach metal stopper (M) using screw (N).
Acople las manijas (G) a las puertas (11,12) con los tornillos (H). Acople el tope metálico (M) con el tornillo (N).

Step 19

Paso 19

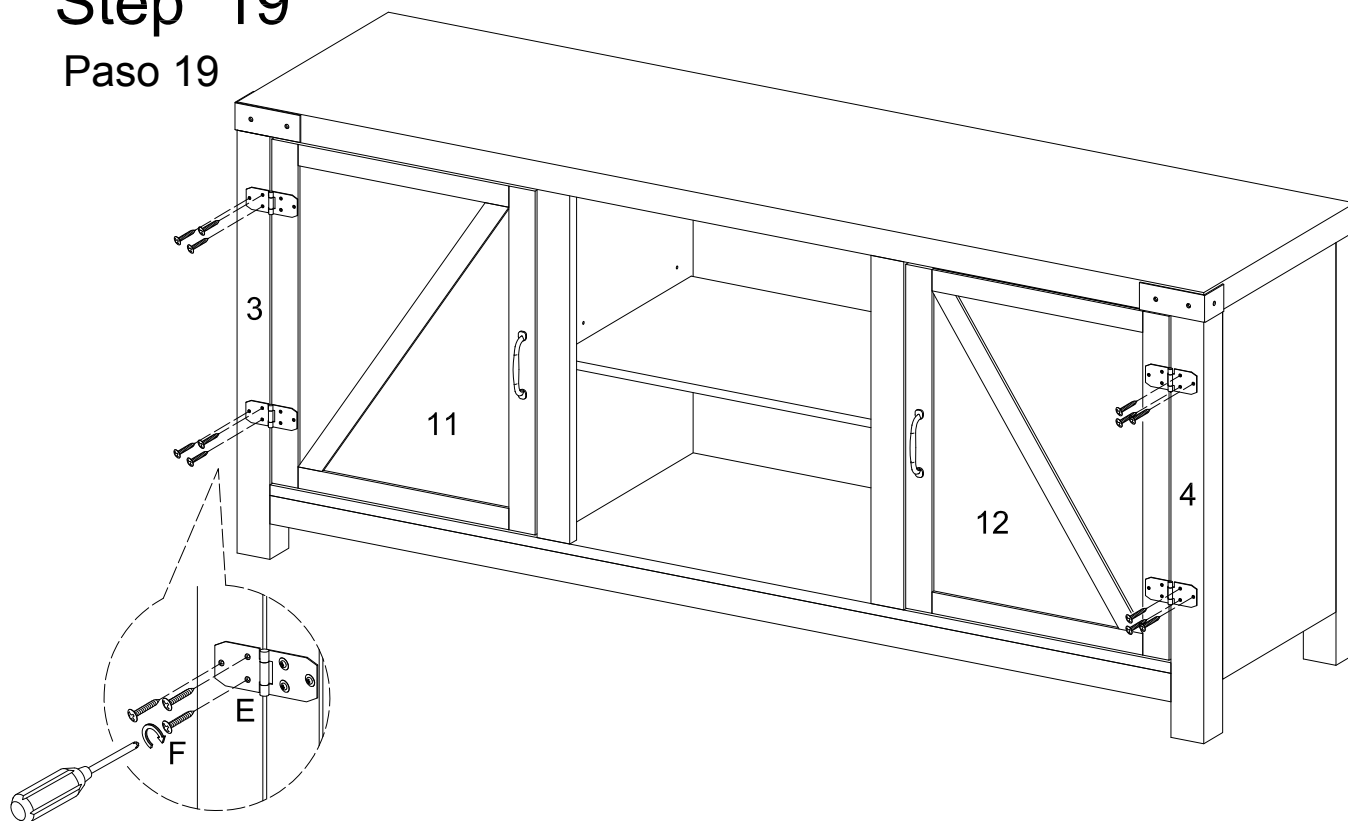

Attach hinges (E) by using screws (F) as shown in the diagram.

Coloque las bisagras (E) con los tornillos (F) como se muestra en el diagrama.

Step 20

Paso 20

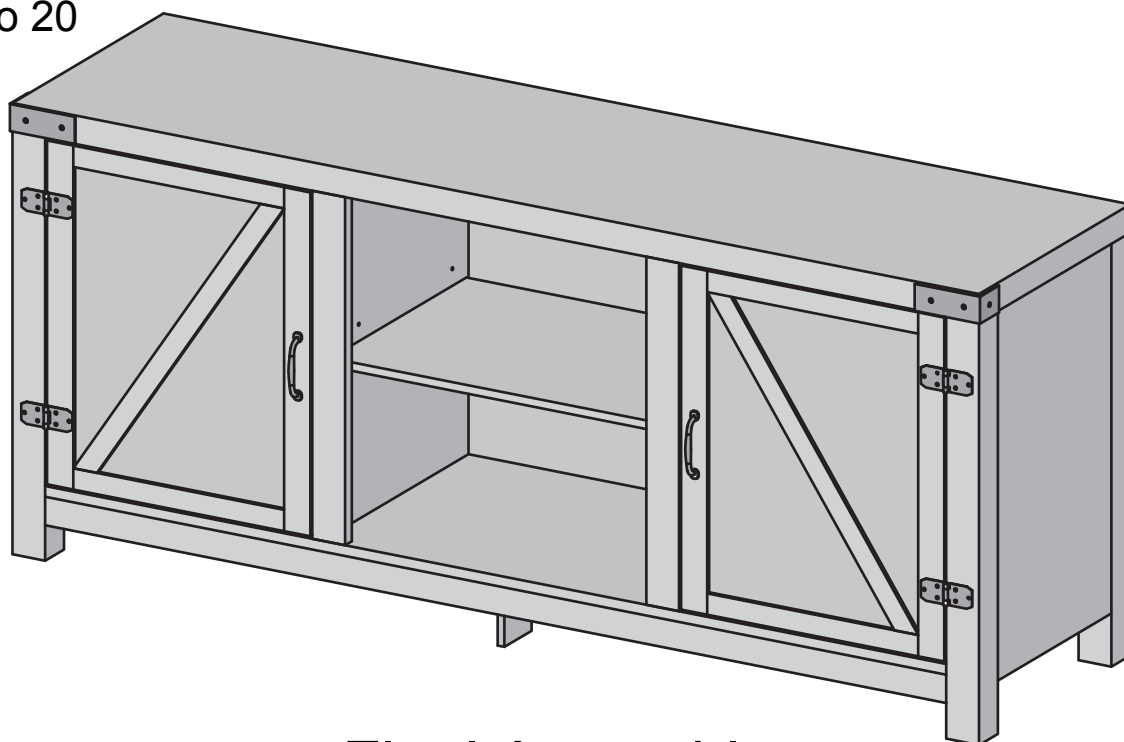

Final Assembly
Ensamblaje final