



Utility Sink

with faucet and storage cabinet

Model No. QL033



Table of Contents

Table of Contents	2	Door Handle Installation	8
Safety Information	2	Door Position Adjustment	9
Warranty	3	Mounting the Utility Sink	9
Lifetime Limited Warranty	3	Placement	10
Warranty Claim Procedure	3	Supply Line Assembly	10
Pre-Installation	4	Maintenance	10
Tools/Materials Required	4	Cartridge Replacement	10
Package Contents	5	Care and Cleaning	11
Installation	6	Utility Sink	11
Faucet Assembly/Installation	6	Cabinet	11
Strainer Installation	7	Service Parts	12
Base Installation	8		

Safety Information

READ AND SAVE THESE INSTRUCTIONS

1. Inspect your unit before proceeding. Once you unpack your unit, check for chips, scratches, cracks, dents or scuff marks. If any damage is noticed, do not install.
2. Use this unit only in the manner intended by the manufacturer. If you have any questions, contact the manufacturer.
3. Installation work and plumbing must be done by qualified person(s) in accordance with all applicable codes and standards.
4. Protect the entire surface during installation.
5. All holes drilled into the unit must be done from the finished surface side with extreme care and caulked very carefully to form a watertight barrier.



DANGER: Always wear safety goggles and gloves in order to avoid personal injury.

Warranty

LIFETIME LIMITED WARRANTY

A thorough inspection must be made before installation and any damage must be promptly reported. We will not be liable for failures or damage that could have been discovered or avoided by proper inspection and testing prior to installation.

We warrant this product to be free from defects in materials or workmanship for as long as the original consumer purchaser owns this product. Proof of purchase (original sales receipt) from the original consumer purchaser must be made available to us for all warranty claims.

This warranty is non-transferable and shall be voided if the unit is removed from its initial installation or if it is not installed following the manufacturer's instructions. It does not apply in the event of product damage due to the use of other than our genuine replacement parts, (Replacement parts may be obtained by calling 1-855-HD-GLACIER between 8:00 am - 6:00 pm EST) installation error, abuse, misuse or improper care and maintenance (whether performed by a plumber, contractor, service provider or member of the purchaser's household). The warranty excludes damage due to aggressive air or water conditions, harsh or abrasive cleaners and/or materials.

Under no circumstance shall we be held liable for personal injury or property damage resulting from improper installation or use of this product. We will not be held liable for inconvenience caused by loss of use of this product, costs incurred for labour or materials, removal and installation of replacement units, or any other incidental or consequential damages. Costs relating to obtaining access for repair or replacement are the responsibility of the user.

Our obligation shall be limited to the repair or replacement of a unit (at our discretion) that may prove, by our sole examination, to be defective under normal use and service during the warranty period.

Any failure of this product that is not traceable to a defect in material or workmanship is not covered by this warranty. These non-warrantable items include, but are not limited to:

- Improper installation not in accordance with manufacturer's instructions.
- Dents and/or scratches incurred during shipping, handling, or installation.
- Change in colour or finish due to chemical usage.
- Damage caused by failure to follow care and cleaning guidelines, including damage caused by the use of abrasive cleaners.
- Alterations made to the unit by the purchaser or installer.
- Damage caused by accidental impact, fire, flood, freezing, and normal wear.
- Bends and warping caused by forced connections, over-tightened fittings, and inadequate support during installation.

This warranty does not extend to commercial and institutional installation or use.

WARRANTY CLAIM PROCEDURE

If a claimable defect occurs or replacement parts are needed, please contact our customer service team at 1-855-HD-GLACIER (8:00 am - 6:00 pm, EST, Monday – Friday).

Before you make your call, please ensure that you have:

- Model number or description.
- Proof of sale.
- Details regarding the defect and/or part number.
- Name(s) and address(es) of the owner and/or installer.

Pre-Installation

TOOLS/MATERIALS REQUIRED (NOT SUPPLIED)



Adjustable wrench



Needle nose pliers



Phillips screwdriver

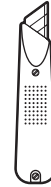

Utility knife



Pipe wrench

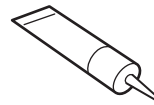

Sealant



Carpenter's level

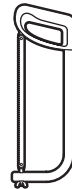

Hacksaw



Safety gloves



Safety goggles

PARTS REQUIRED (NOT SUPPLIED)



Tail Pipe



P-Trap

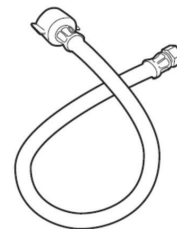

Supply line

Pre-Installation (continued)

PACKAGE CONTENTS

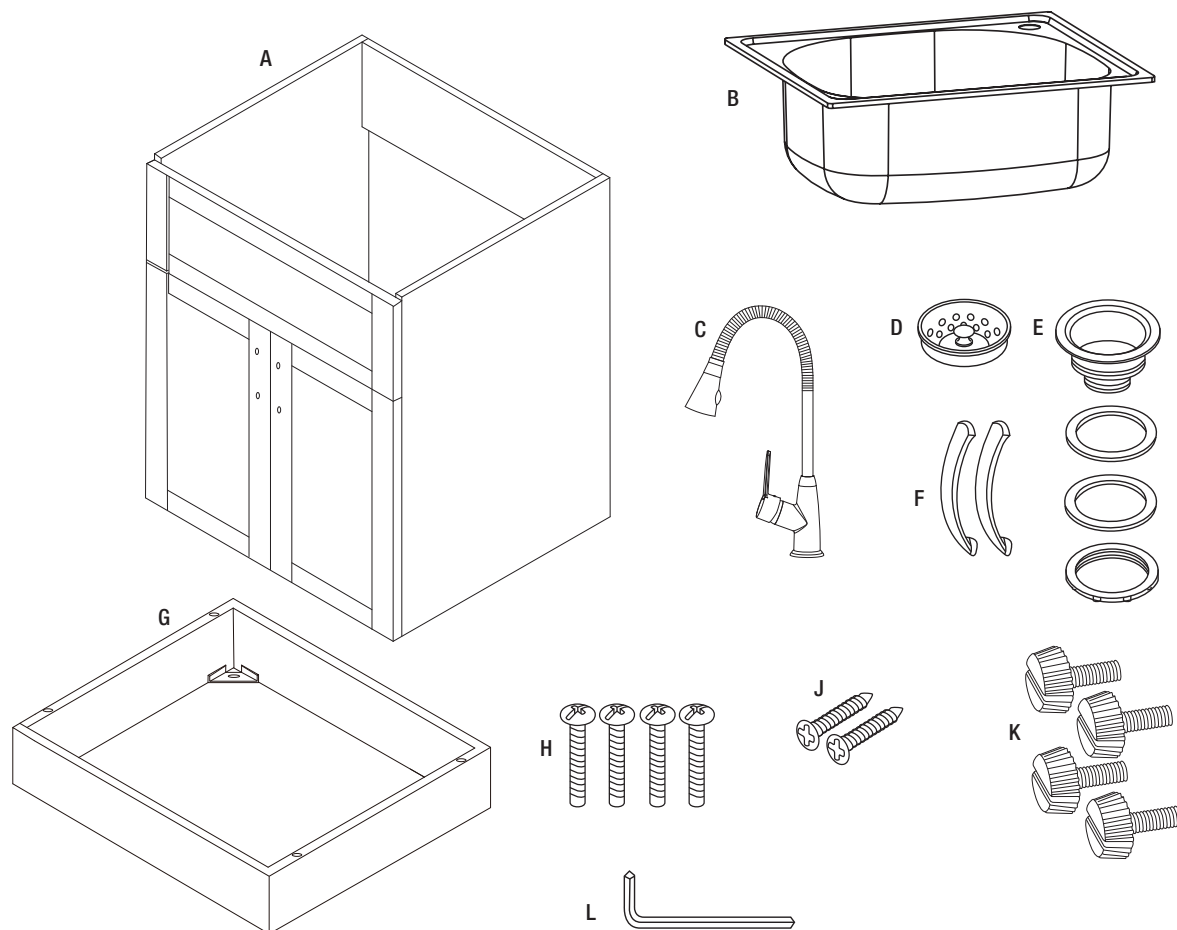

Part	Description	Quantity
A	Cabinet	1
B	Utility Sink	1
C	Faucet	1
D	Strainer Basket	1
E	Strainer Assembly	1
F	Door Handles	2
G	Cabinet Base	1
H	Door Handle Screws	4
J	Cabinet Base Screws	2
K	Cabinet Feet	4
L	Allen Key	1

Installation

FAUCET ASSEMBLY/INSTALLATION

1. Carefully take out all the parts of the faucet assembly (C). The faucet is pre-assembled, except for the sprayer head.
2. Take the washer, gasket and retaining ring off of the faucet body.
3. Place the faucet body carefully through the hole in the sink (B). A second person may be required to hold the body in place until the faucet installation is complete.
4. From underneath, slide the washer, gasket and retaining ring over the end of the copper pipe and up to the exposed threaded section of the faucet. Tighten the retaining ring by hand until it is snug. Using a wrench or pliers, tighten the assembly.
5. Gently tighten the two screws on the retaining ring. Do not over tighten.
6. Screw the sprayer head onto the gooseneck pipe.
7. Connect the water supply lines (not supplied) to the faucet.

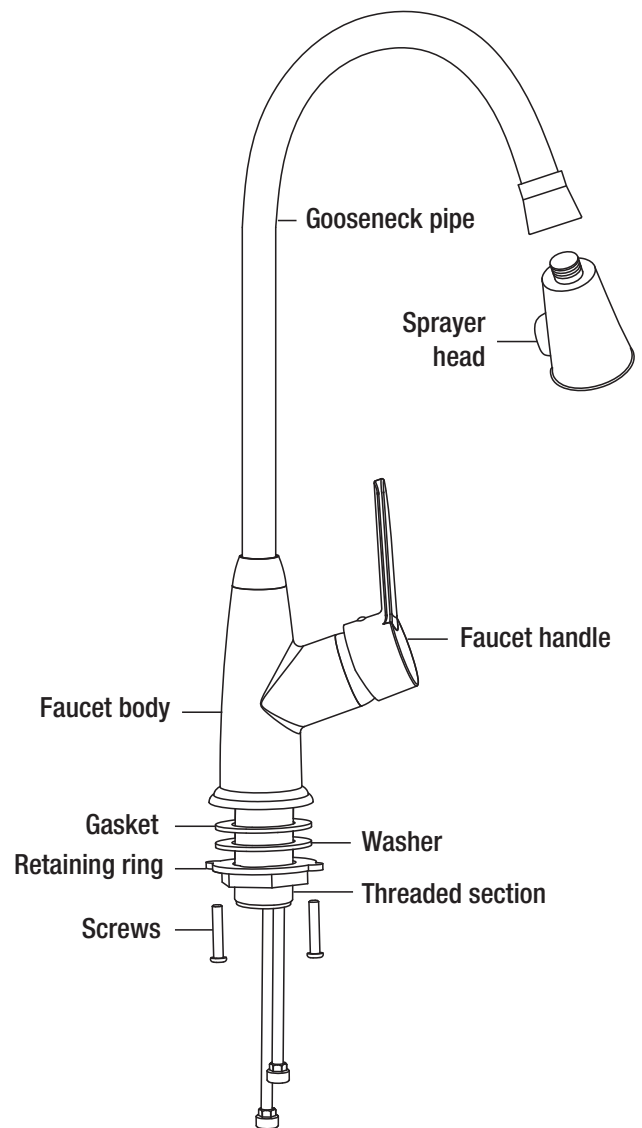

Installation (continued)

STRAINER INSTALLATION

1. Apply a ring of sealant to the underside of the strainer flange.

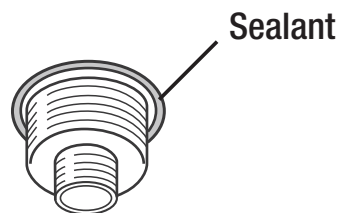

2. Insert the strainer body into the sink.

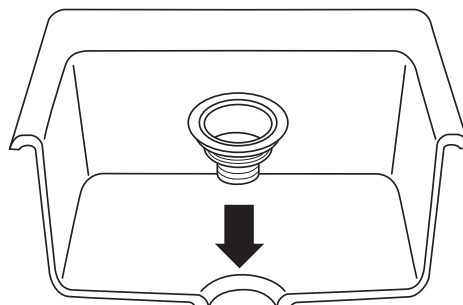

3. Assemble the rubber gasket, friction washer and locknut onto the strainer body from under the sink.

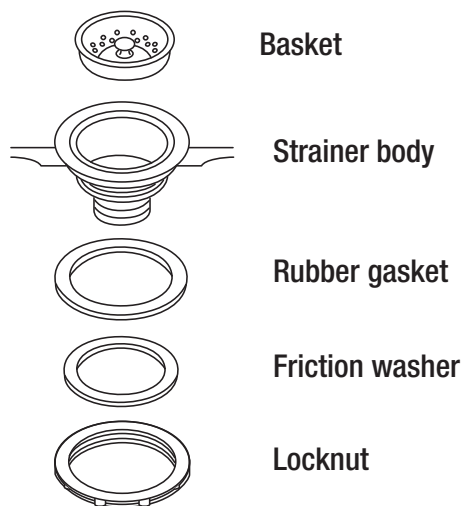

4. Hand tighten the locknut. Do not over tighten the locknut as it may split or deform the strainer body.

Installation (continued)

BASE INSTALLATION

A thorough inspection must be made before installation and any damages or missing parts must be promptly reported. Do not proceed with the installation. Do not dispose of packaging before you are satisfied with your new utility sink.

1. Unpack the unit and place the sink (B) on a blanket or cardboard to protect the surface.
2. Turn the cabinet (A) upside down onto the protective surface.
3. Gently attach the cabinet base (G) onto its proper location. Using the supplied base screws (J), attach the base to the cabinet.
4. Attach cabinet feet (K) to the base.
5. Gently place the cabinet upright.



CAUTION: Do not place side load onto feet when righting the cabinet.

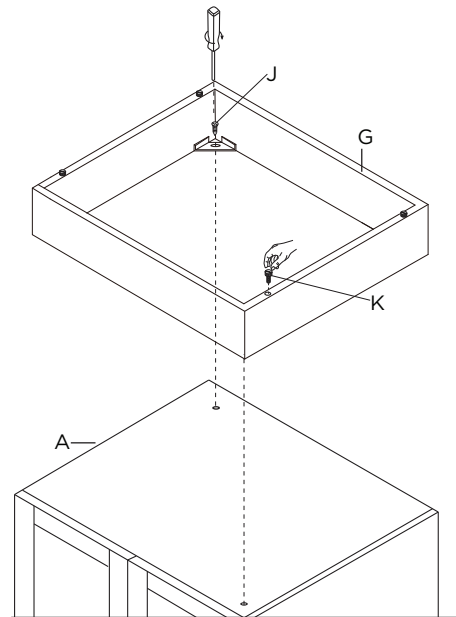

DOOR HANDLE INSTALLATION

1. Insert the door hand screws (H) into the pre-drilled holes on each door.
2. Attach the door handles (F) and hand tighten the door handle screws (H).
3. Repeat on other door.

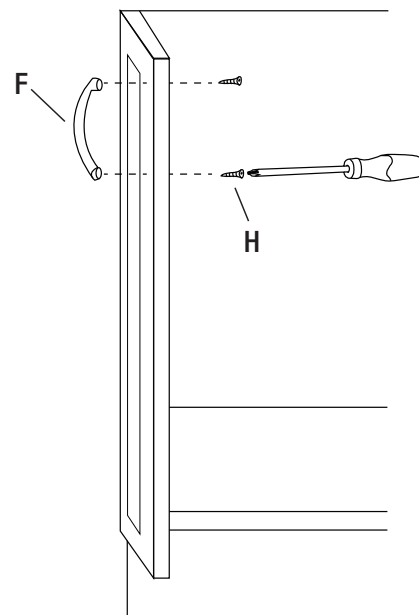

Installation (continued)

DOOR POSITION ADJUSTMENT

If the doors need to be repositioned, the hinges can be adjusted to ensure a precise fit with the cabinet.

1. The lateral adjustment screw adjusts the door left or right.
2. Horizontal adjustment of the screws adjust the door forward and backward.
3. Vertical adjustment of the screws adjust the door up and down.

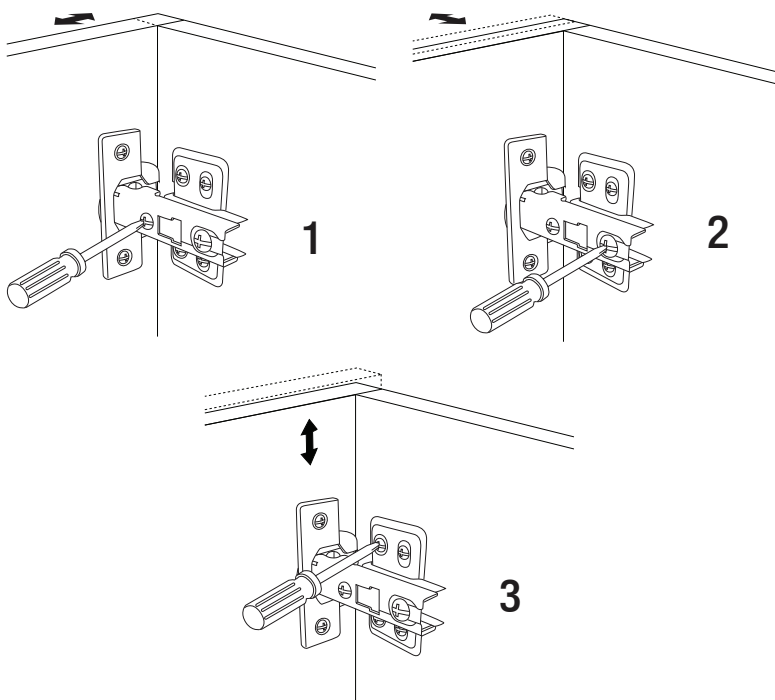

MOUNTING THE UTILITY SINK

1. Carefully place a bead of sealant all around the top of the cabinet (A).
2. Ease the sink (B) into the cabinet (A), ensuring that it is placed evenly and is centered on the cabinet. Wipe off any excess sealant. Use masking tape to hold the sink in place until the sealant dries.

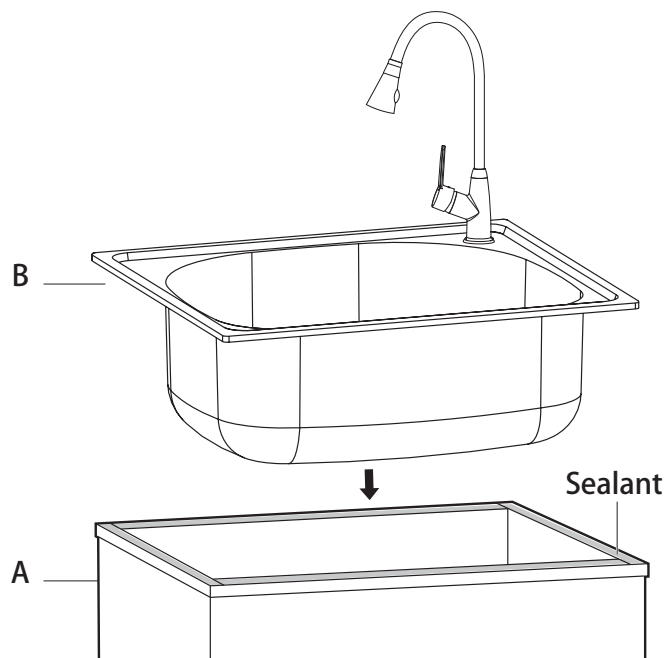

Installation (continued)

PLACEMENT

Move the assembled unit to its final location. Final hook up of the supply lines and drain system can now be completed.

SUPPLY LINES (NOT INCLUDED)

The supply lines that attach the faucet to the household water system, are not supplied with this unit. They need to be purchased separately.

Follow the manufacturers instructions for proper installation of the supply lines.

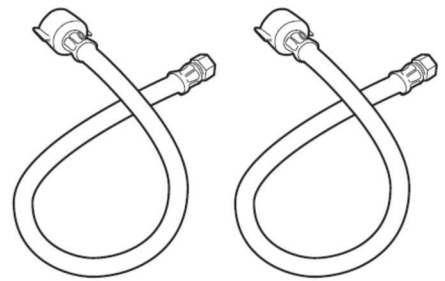

Maintenance

CARTRIDGE REPLACEMENT

1. Before proceeding, turn off the water supply to the faucet.
2. Take off the plastic water indicator by hand, then use the Allen key to remove the screw and pull out the handle body. The top lever of the cartridge will be exposed.
3. Unscrew the cap and rings, making sure not to damage the threads.
4. Pull out the cartridge and replace it with a new 35 mm (1.4 in.) ceramic cartridge.
5. Replace the rings and the cap.
6. Place the handle body on the cartridge. Lock the screw onto the handle body and tighten it with the Allen key. Do not over tighten.
7. Put the plastic water indicator back into the hole, make sure the red is on the left and blue is on the right.

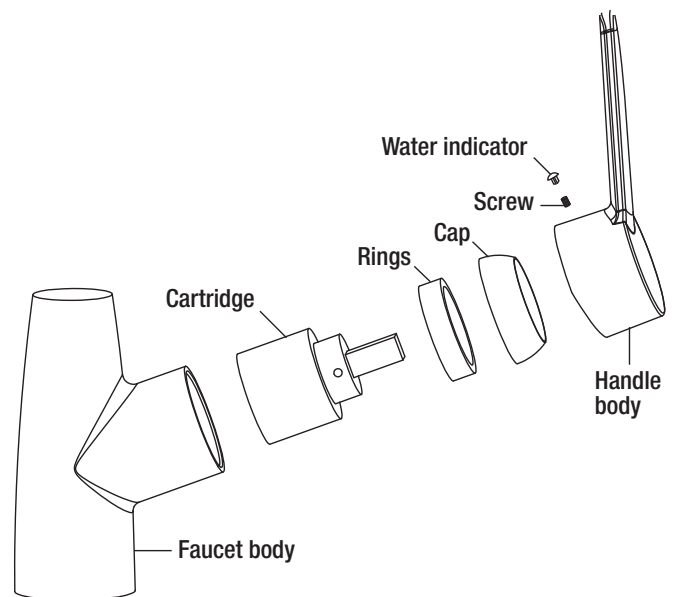

Care and Cleaning

UTILITY SINK

Your sink is manufactured with the highest grade stainless steel and will provide you many years of enjoyment with the proper care.

Do
<ul style="list-style-type: none">- After use, always rinse your sink with tap water to dilute and remove deposits.- Towel dry after use whenever possible to prevent water spots. Should water spots occur, clean with a mild solution of vinegar and water followed by a thorough rinse.- Use liquid soap, a general household cleaner, or a weak solution of vinegar and water for regular cleaning.- Only use plastic scouring pads recommended for use in stainless steel sinks, and only use them in the bowl of the sink. Scrub in the direction of the satin finish lines.

Do not
<ul style="list-style-type: none">- Do not allow any food, detergent, soap or grease to dry or sit for extended periods of time on the surface of the sink.- Never use abrasive cleaning products, as they will dull and scratch the finish.- Do not use scouring pads on the deck, as they will dull the mirror finish.- Never use steel wool pads, as they will leave iron particles on the sink, which will cause corrosion.- Never leave steel or cast iron pans in your sink for extended periods of time, as this can cause corrosion.

CABINET

To maintain the surface of your cabinet, follow these tips.

Do
<ul style="list-style-type: none">- Remove dust and dry dirt with a soft, damp cloth.- Clean grease, oil, paint and ink stains with isopropyl (rubbing alcohol). Immediately rinse with water after stain removal.

Do not
<ul style="list-style-type: none">- Do not allow your cabinet surface to come into contact with products such as acetone (nail polish remover), nail polish, dry cleaning solution, lacquer thinners, gasoline, pine oil, etc.- Use caution when using sharp instruments that may fall and scratch the surface.

Service Parts

If you are missing parts or if you require replacement parts, please contact our customer service team at 1-855-HD-GLACIER, 8:00 am – 6:00 pm, EST, Monday–Friday. Identify the required part(s) and have the part number(s) ready.

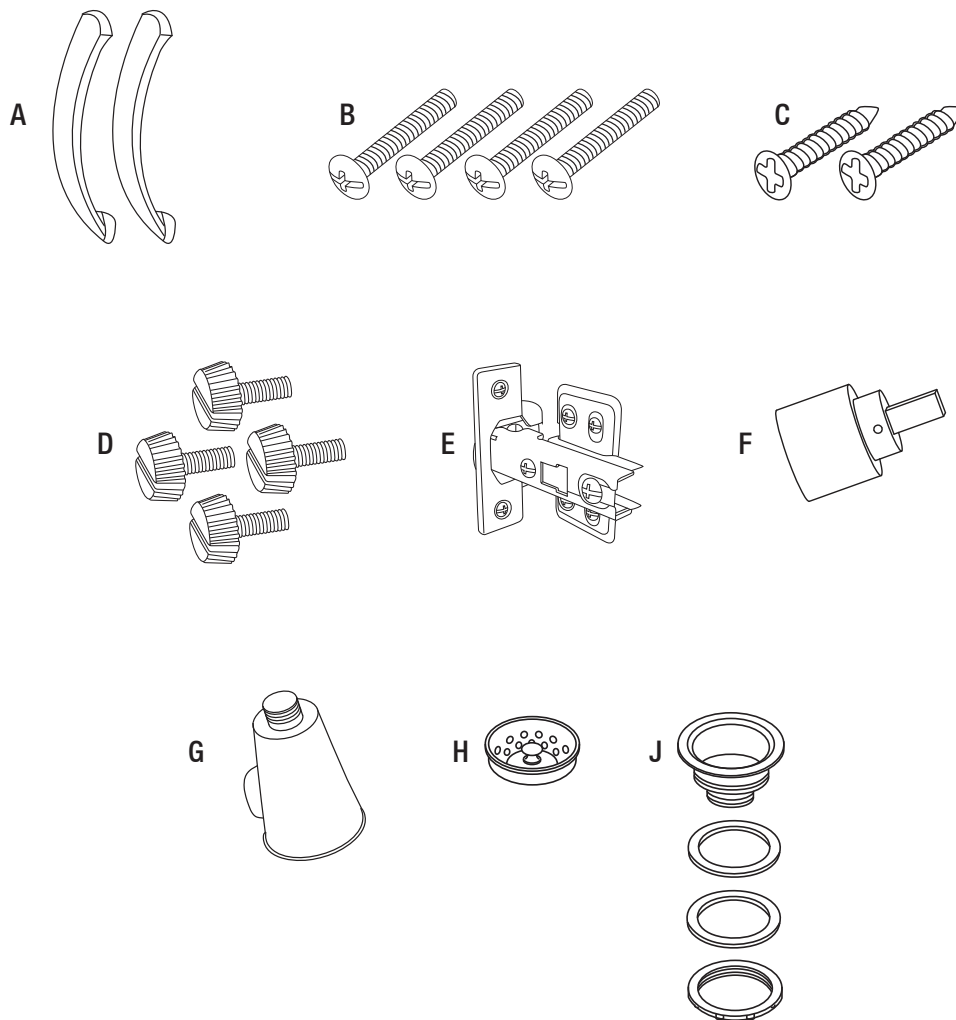

Part	Description	Code	Quantity
A	Door Handles	QHL122	2
B	Door Handle Screws	QHL104	4
C	Base Screws	QHL108	2
D	Cabinet Feet	QHL107	4
E	Cabinet Hinges	QHL102	4
F	Ceramic Cartridge	QHS121	1
G	Sprayer Head	QHS181	1
H	Strainer Basket	QHS101	1
J	Strainer Assembly	QHS150	1



Questions, problems, missing parts?

Before returning to the store, call Customer Service
8:00 am - 6:00 pm, EST, Monday - Friday
1-855-HD-GLACIER

[HOMEDEPOT.COM/GLACIERBAY](https://www.homedepot.com/glacierbay)

Retain this manual for future use.