

HOME DECORATORS COLLECTION

MD-V48-SF

Stanford 48" Single Bath Vanity

ITEM#:9916500270

MFG#: MD-V48-SF

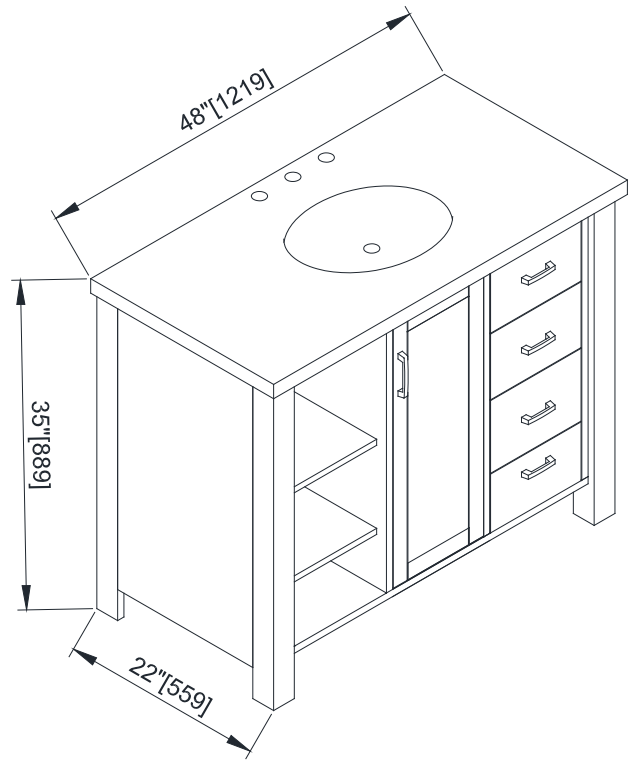

Measures: inch

DIMENSIONS/DIMENSIONES

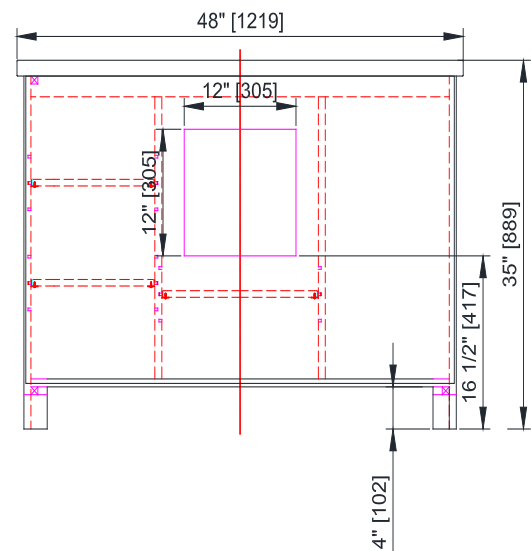
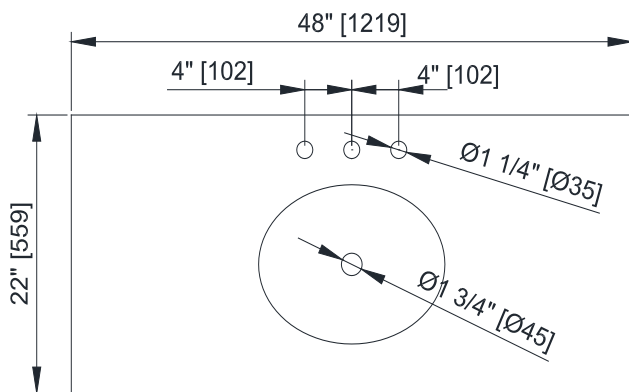

Installation Manual

- Carefully read the instructions before starting the installation.
- This vanity should be installed by an experienced plumber.
- Drain pipe and drain trap are not supplied. Connect to an existing drain pipe.

PARTS

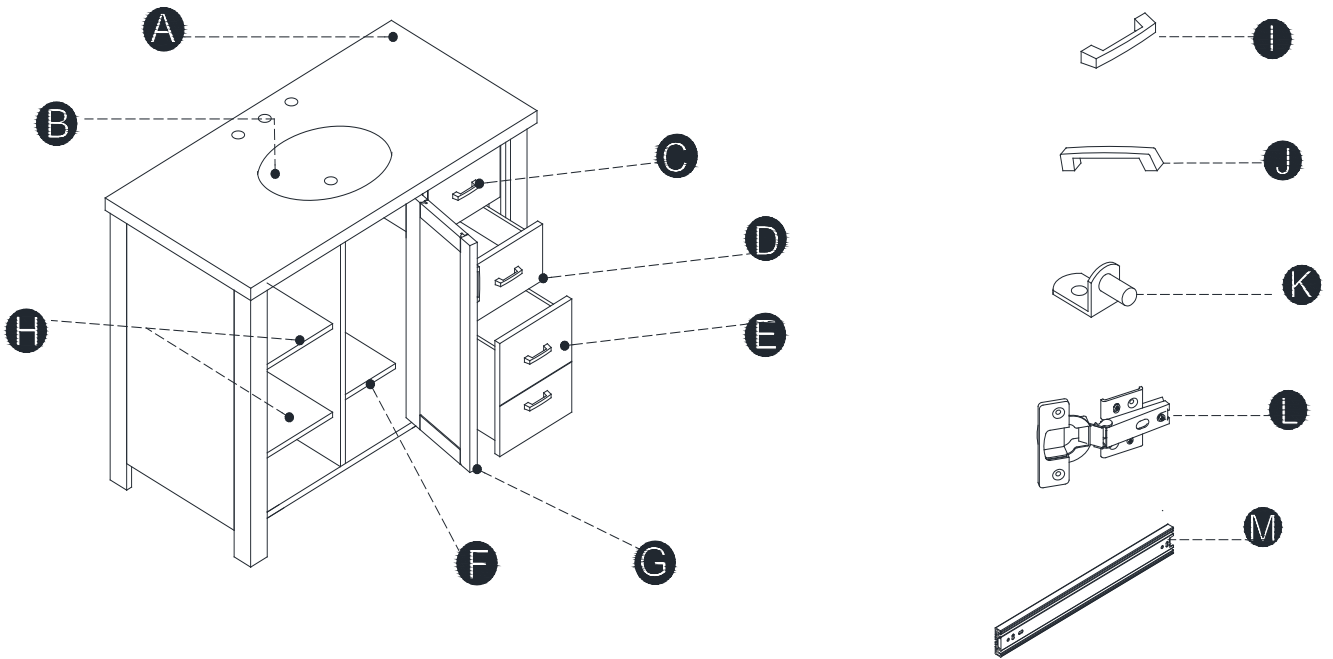

	Item	Qty
A	Countertop	1
B	Basin	1
C	Top Drawer	1
D	Middle Drawer	1
E	Bottom Drawer	1
F	Adjustable Shelf (middle)	1
G	Door	1

	Item	Qty
H	Adjustable Shelf (Left)	2
I	Drawer Handle	4
J	Door Handle	1
K	Shelf Holder	12
L	Hinge	2
M	Glide	3

DRAWER

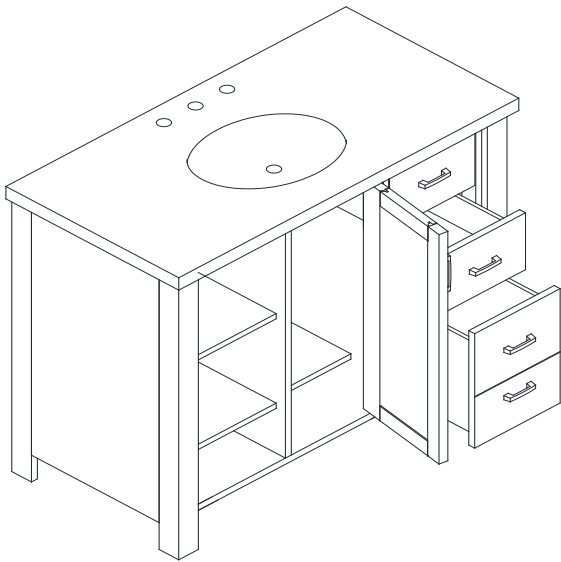

1

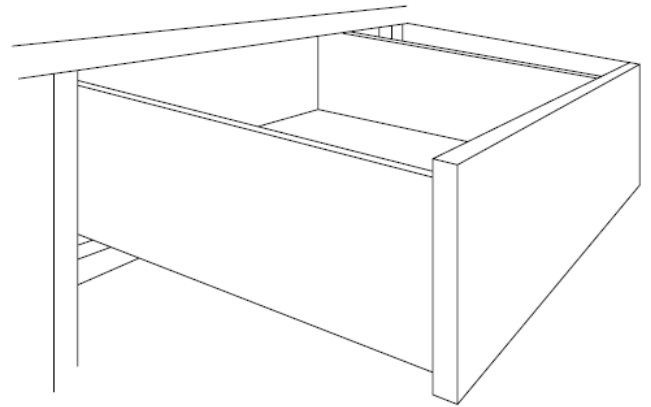

2

3

4

REMOVE

1

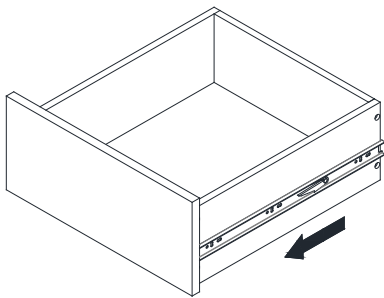

2

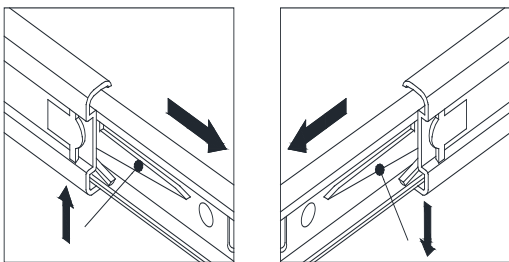

INSTALL

1

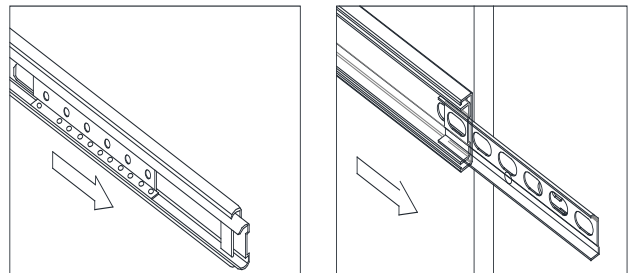

2

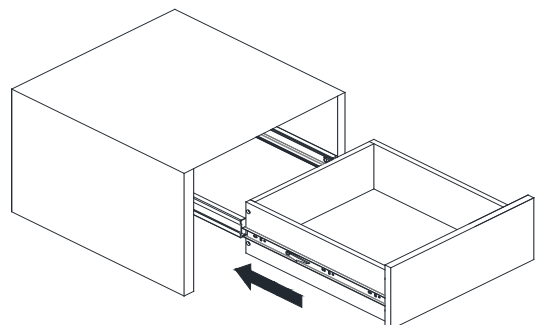

SHELF

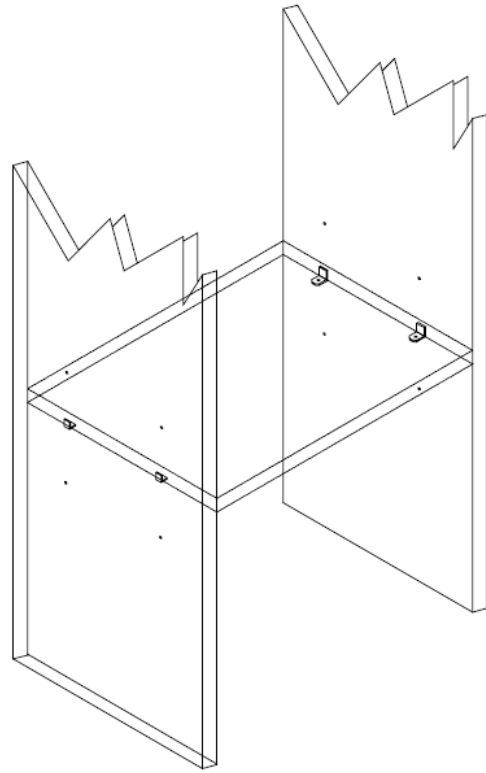

REMOVE

1

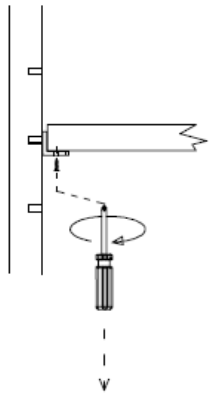

2

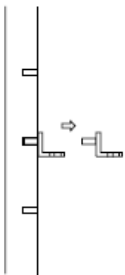

INSTALL

1

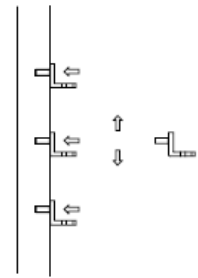

2

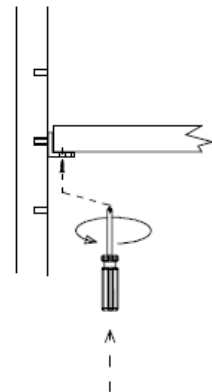

LIMITED 1 YEAR WARRANTY

This warranty applies to the DISTRIBUTOR vanities installed for commercial and residential use.

The DISTRIBUTOR warrants that, when installed in accordance with the Recognized Plumbing Industry Practice, the vanities are free of manufacturing defects for a period of one (1) year from the date of purchase.

We guarantee your satisfaction with each vanity. Should any vanity not meet your satisfaction due to a visual defect, simply return it to your retailer with the original packaging, PRIOR TO INSTALLATION, for a replacement.

This warranty applies only to the original purchaser and installation site and is not transferable.

INFORMATION ABOUT YOUR WARRANTY COVERAGE

This warranty does not cover damages or failure attributable to:

- ▶▶ Vanities installed with obvious visual defects.
- ▶▶ Defects or damages to vanities caused by installation that does not comply strictly with the instructions set forth in the DISTRIBUTOR's installation manual.
- ▶▶ Defects or damage to vanities caused by severe accidents (e.g., fire, impacts).
- ▶▶ Damage caused by flooding or standing water from leaking pipes, faucets, household appliances, etc; up to and including flooding and any damage caused by acts of God.

FOR WARRANTY SERVICE

- **To** make a claim, contact the DISTRIBUTOR no later than 30 days following the date of discovery or detection of defect.
- **Proof** of purchase, such as the bill of sale is mandatory when requesting warranty service.
- **The** DISTRIBUTOR reserves the right to designate a representative to inspect the vanity for analysis.
- **No** unauthorized person, installer, dealer, agent or employee of th DISTRIBUTOR or any representative is entitled to assume any liability on behalf of the DISTRIBUTOR relating to the sale of this product or has the authority to increase or alter the obligations or limitations of this warranty.

THE SOLE REMEDY PROVIDED BY THIS WARRANTY IS THE REPAIR OR REPLACEMENT OF DEFECTIVE PRODUCTS.

THIS WARRANTY DOES NOT COVER THE COST OF REMOVAL OR INSTALLATION OF NEW PRODUCTS.
THE WARRANTY WILL BE VOID IF THIS ITEM IS INSTALLED WITH OBVIOUS VISUAL DEFECTS.