

Assembly Instructions

WB100 Heavy-Duty Carbon Steel Walk Behind Salt Spreader

WB200 Heavy-Duty Stainless Steel Walk Behind Salt Spreader

Check contents of box against parts list to make sure all components are included. When ordering replacement or spare parts refer to parts list for part numbers.

TOOLS NEEDED FOR ASSEMBLY

- 2 x 10mm wrench
- Slotted screwdriver

Frame Assembly - Fig. 1

- Assemble the frame with fasteners as shown in Figure 1. **Do NOT tighten the fasteners yet.**
- The Support Brackets (16) will be fastened to the Hopper Support Assembly (3) when the Hopper (4) is mounted.
- Tighten all fasteners.

Axle/Gearbox & Hopper Assembly - Fig. 2 & 3

- Insert the Axle (7) into the frame and through the Gearbox (5) as shown. **IMPORTANT** - The end of the axle with a large hole (for a through bolt) must be on the left side (standing in front of the spreader – as shown in Figure 1). The arrow on the Gearbox should be pointing towards the rear of the spreader.
- Fasten the Gearbox to the Axle using an M6x40 HH Cap Screw.
- Mount the Axle Bushings (19) and Wheels (6A/B) on both ends of the axle. Mount two Shim Washers (20) between each wheel and outer bushing. Mount the additional Shim Washer between the Coast Wheel (6B) and the Cotter Pin (17). Only the Drive Wheel (6A) is fixed to the Axle with an M6x45HH Cap Screw. The Coast Wheel rotates freely on the axle and is retained by a Shim Washer and Cotter Pin.



WB100 Shown

IMPORTANT

The Shim Washers and extra Axle Bushings are critical for proper operation. There should be no more than 1/16" of endplay when the axle assembly is complete. Every assembly should have 4 axle bushings and 5 shim washers.

- Lower the Hopper Assembly (4) over the agitator shaft. The Hopper Supports Bracket (16) are fastened to the REAR hopper fasteners (M6x50 Machine Screws) as shown in Figure 2. The Deflector Assembly (12) is fastened to the FRONT hopper fasteners (M6x50 Machine Screws) as shown in Figure 3. The deflector flap positions may be adjusted and locked using the wing nuts.
- If the agitator shaft on the Gearbox does not align with the hopper, check the Axle and Gearbox installation direction.
- Verify that the spinner disk rotates counter-clockwise when the spreader is pushed forward. If it does not, the Axle/Gearbox assembly has been installed backwards.

Handle/Control Linkage Assembly - Fig. 4 & 5

- Carefully insert the Lower Linkage (11) into the

—continued inside

Restrictor Plate underneath the hopper. The Lower Linkage has two bent ends. The Upper Linkage has one threaded end. **NOTE: The short bent section of the lower linkage should be parallel with the bottom of the hopper/restrictor plate.**

B. Temporarily remove the Linkage Plate (15) and insert the other end of the Lower Linkage into the front hole on the Linkage Plate.

C. Remount the Linkage Plate to the frame. It is important that it be installed as shown for proper operation.

D. Slide the Handle (8) on to the spreader frame and set to the desired height by aligning two of the holes in the handle assembly with holes in the frame. It may be helpful to LOOSEN the fastener in the Upper Frame Assembly.

E. Mount the Control Handle Assembly (9) to the selected two holes using 2x M6x70 HH Cap Screws.

F. Insert the Upper Linkage (10) into the Control Handle as shown.

G. Thread one M6 jam nut onto the Upper Linkage and insert into the Linkage Plate.

H. Adjust the M6 jam nut so that the Restrictor Plate underneath the hopper is fully open when the Control Handle is at "30". Assemble the second jam nut in this position to lock the linkage in place.

I. Verify that the Restrictor Plate may be fully closed by pushing the Control Handle forward.

Final Assembly

A. CHECK AND TIGHTEN ALL FASTENERS – Adjust frame for alignment as fasteners are being tightened.

B. Install the Plastic Screen (13) into the hopper.

C. Install the Rain Cover (14) over the hopper.

Operation

1. Before filling hopper, ensure that the restrictor plate is fully closed, i.e. that the control handle is fully forward.

2. Move and tighten the stop bolt to the desired setting.

3. Begin moving forward with the spreader

4. Pull the control handle back to the stop bolt

5. Before stopping, push the control handle fully forward to stop flow.

Maintenance

1. The spreader hopper and spinner plate should be completely emptied and cleaned before storage.

2. The spreader should be washed and dried before storage.

3. Check that the restrictor plate and linkage move

freely. Clear out any debris between restrictor plate and hopper.

4. Check torque of all fasteners on a monthly basis.

Operation Notes:

CAUTION

When filling hopper, make certain there are no large objects contained in the material, which can cause the spreader to clog or damage the gearbox. Never leave material in the hopper for an extended period of time.

1. The restrictor plate has three flow holes suitable for a wide range of de-icing products. The third flow hole has an adjustable restrictor to eliminate or reduce its flow. In cases where the product is intended to be spread in a forward pattern, this hole should be covered.

2. The spreader is designed to be operated at a brisk walking pace (approximately 3 mph). Walking slower or faster will alter the distribution pattern and amount of the product, as will the moisture content of the material and other environmental factors.

3. Do not attempt to lubricate the gearbox. The gearbox is lubricated and sealed at the factory to avoid contamination.

FULL ONE YEAR WARRANTY

Manufacturer will repair, or at manufacturer's discretion will replace any part of this salt spreader which proves to be defective in workmanship or material under normal use for a period of one year from the date of delivery to the original purchaser. Any cost incurred in returning the product to the supplier is the responsibility of the consumer.

EXCLUSIONS

Manufacturer shall not be liable for special, incidental, or consequential damages, or for damages resulting from lack of necessary maintenance, from misuse, abuse, acts of God, or alteration of the product. Some states do not allow the exclusion or limitation of incidental or consequential damages, so the above limitation or exclusion may not apply to you.

Fastner Selection Guide

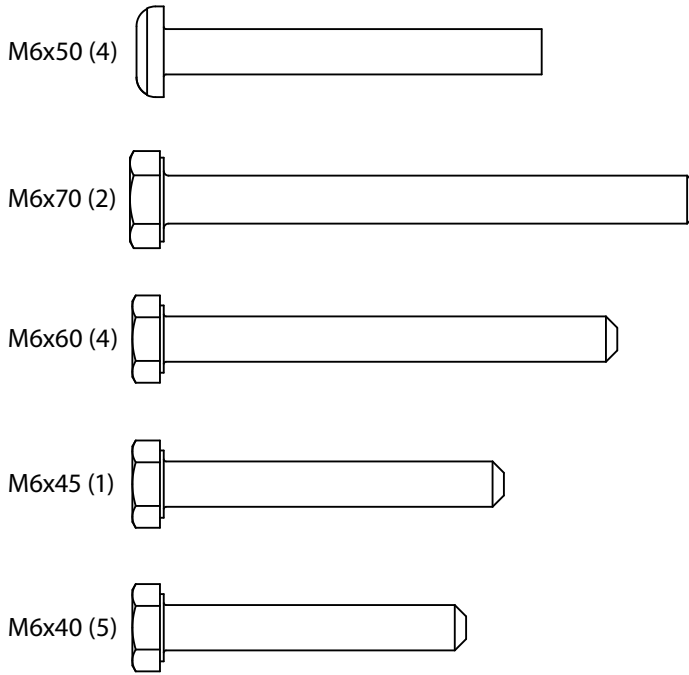

Frame Assembly

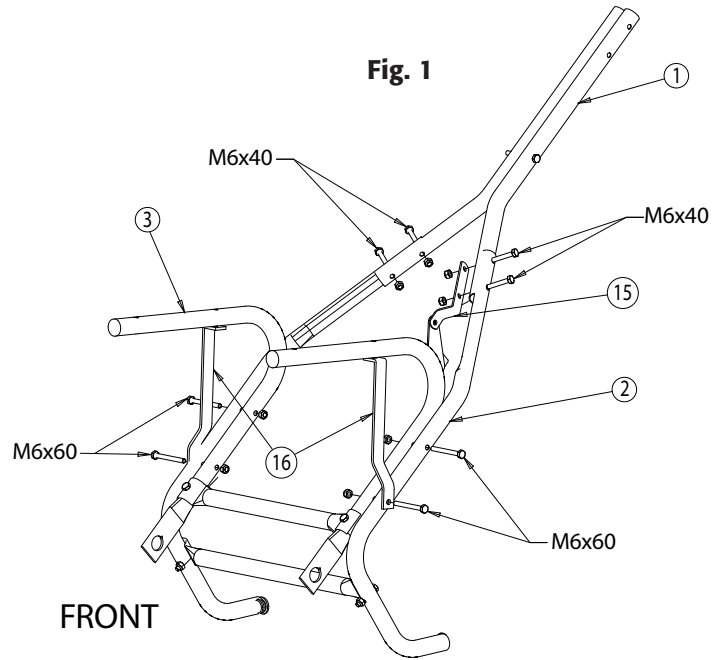

Axle / Gearbox and Hopper Assembly

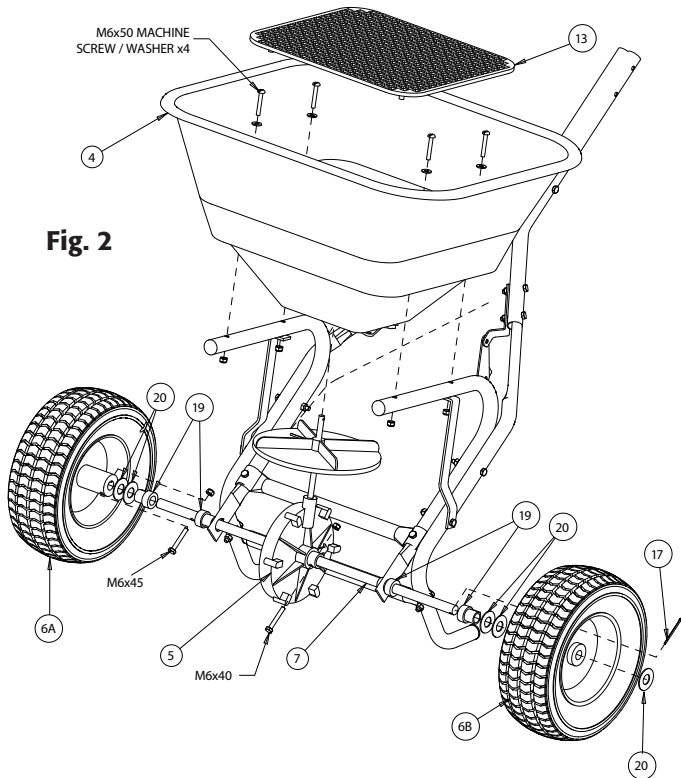

Deflector Assembly

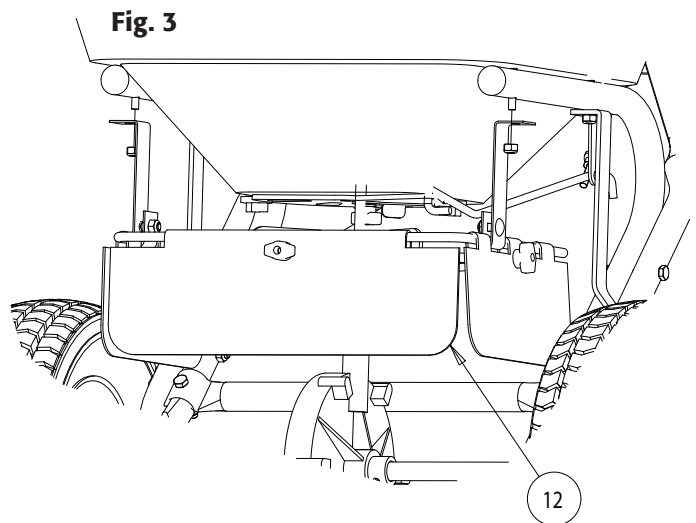

Control Handle Assembly

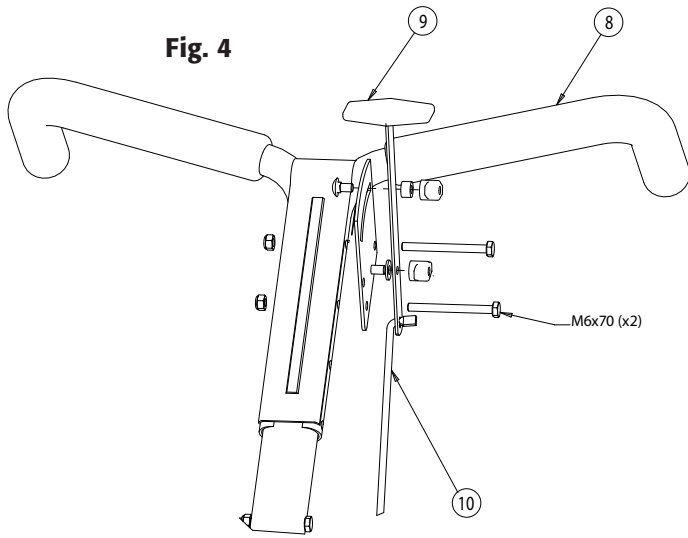

Linkage Assembly

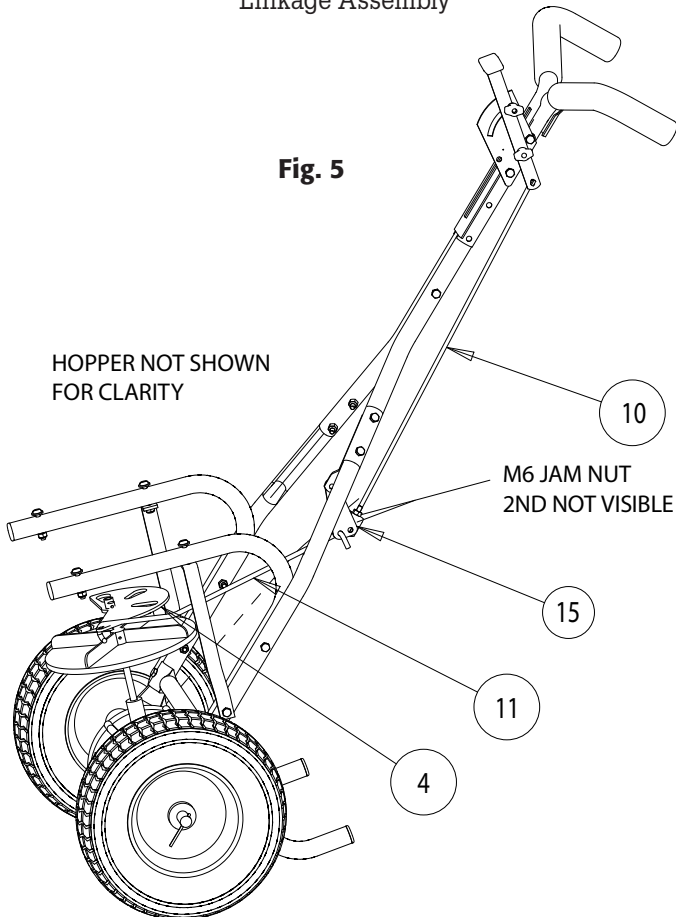

Bill of Materials (for all drawings)

CS = WB100

SST = WB200

ITEM	PART NO.	QTY	DESCRIPTION
1	3008136CS/SST	1	UPPER FRAME ASSY
	3007853CS/SST	2	Upper Frame
	3008118	1	M6x50 Hex Head Cap Screw
	3008123	1	M6 Locking Nut
2	3008137CS/SST	1	LOWER FRAME ASSY
	3007854CS/SST	1	Lower Frame (Left)
	3007855CS/SST	1	Lower Frame (Right)
	3007857CS/SST	1	Long Crossmember
	3008116	2	M6x40 Hex Head Cap Screw
	3008123	2	M6 Locking Nut
3	3008138CS/SST	1	HOPPER SUPPORT ASSY
	3007856CS/SST	2	Hopper Support
	3007858CS/SST	1	Short Crossmember
	3008116	2	M6x40 Hex Head Cap Screw
	3008123	2	M6 Locking Nut
4	3008139	1	HOPPER ASSY
	3007861	1	Hopper
	3007872	1	Restrictor Assembly
5	3008140	1	GEARBOX/SPINNER ASSY
	3007863	1	Spinner
	3007875	1	Cotter Pin
	3007864	1	Gearbox
6a	3007862	1	DRIVE WHEEL
6b	3008135	1	COAST WHEEL
7	3007934	1	AXLE
8	3007866CS/SST	1	HANDLE
9	3008141	1	CONTROL HANDLE ASSY
	3007867	1	Control Handle
	3007868	1	Plastic Washer
	3007869	1	Control Plate
	3007876	1	Stop Spacer
	3007874	2	M6 Wing Nut
	3008122	1	M6x20 Carriage Bolt
10	3007870	1	UPPER LINKAGE
11	3007871	1	LOWER LINKAGE
12	3008142	1	DEFLECTOR ASSY
	3007874	3	M6 Wing Nut
	3007877	1	Long Deflector
	3007878	2	Short Deflector
	3007879	1	Deflector Rod
	3007880	1	Deflector Hanger
	3008122	5	M6x20 Carriage Bolt
	3008123	2	M6 Locking Nut
13	3007881	1	SCREEN
14	3007993	1	RAIN COVER
15	3007859	1	LINKAGE PLATE
16	3007860	2	HOPPER SUPPORT BRACKET
-	-	1	HARDWARE BAG
17	3007875	1	Cotter Pin
19	3007865	4	Axle Bushing
20	00700601	5	Axle Spacer Shim
	3008116	5	M6x40 Hex Head Cap Screw
	3008117	1	M6x45 Hex Head Cap Screw
	3008119	4	M6x60 Hex Head Cap Screw
	3008120	2	M6x70 Hex Head Cap Screw
	3008121	4	M6x50 Machine Screw
	3008125	4	M6 Flat Washer
	3008123	16	M6 Locking Nut
	3008124	2	M6 Jam Nut