

**Everwood Cordoba 3 piece seating set**  
**ASSEMBLY INSTRUCTIONS**  
**SR-K-137E/3**

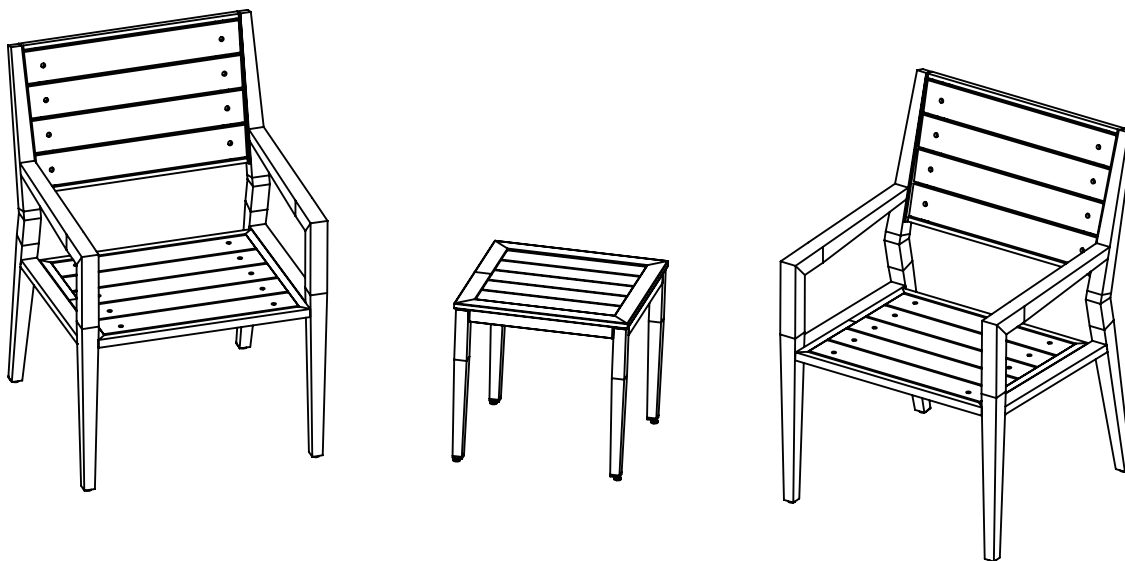

Questions, problems, missing parts with this product? Do not return to your retailer, please call our customer service department 9:00 a.m. to 5:00 p.m. Eastern Standard Time Monday through Friday Phone # 1-800-457-4652 or contact us at [www.numarkcustomerservice.com](http://www.numarkcustomerservice.com)



**Care and Maintenance**

Though its powder-coated finish is rust-resistant, steel is prone to rust over time with exposure to the elements. In case of rust or scratches, lightly sand the affected area and apply touch-up paint. To maintain the finish periodically apply wax with a soft cloth.

Wash frames with a mild solution of soap and water; rinse thoroughly. Do not use bleach or solvents.

Do not store anything on tabletop. Use furniture covers or store indoors during cold or inclement weather.

# Parts

- A table top 1  
(Attached with 8 bolts and 8 washers)
- B leg 2  
(Attached with 4 bolts and 4 washers)
- C connector bar 2
- D1 left arm 2
- D2 right arm 2
- E seat 2
- F back 2

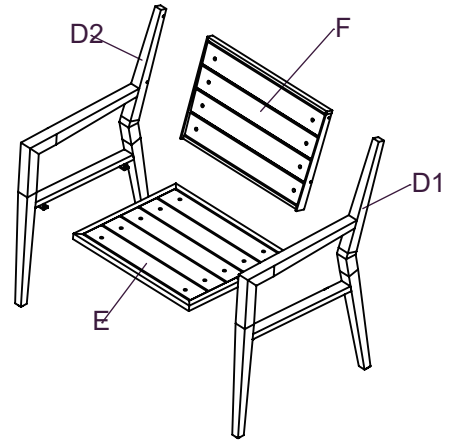
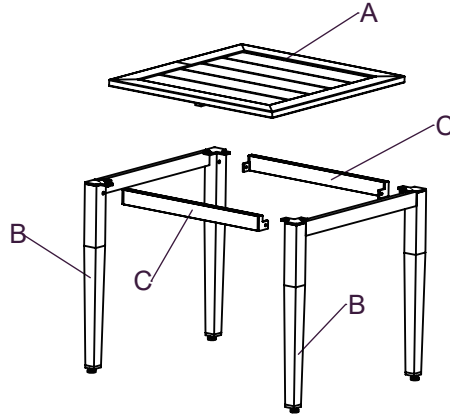

## Hardware

Ga x 8 +1 spare

Sunk Screw



Gb x 8 +1 spare

Bolt



Gc x 8

Metal Washer



Gd x 1

Allen Wrench

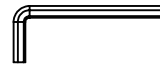

Ge x 1

Assembly Instructions Sheet

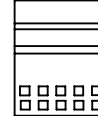

## Assembly instruction

**1**

Gb x 8  
Bolt  
(Remove from table top)

Gc x 8  
Metal washer  
(Remove from table top)

Do not tighten completely.  
Repeat procedure for the other three legs.

# Assembly instruction

2

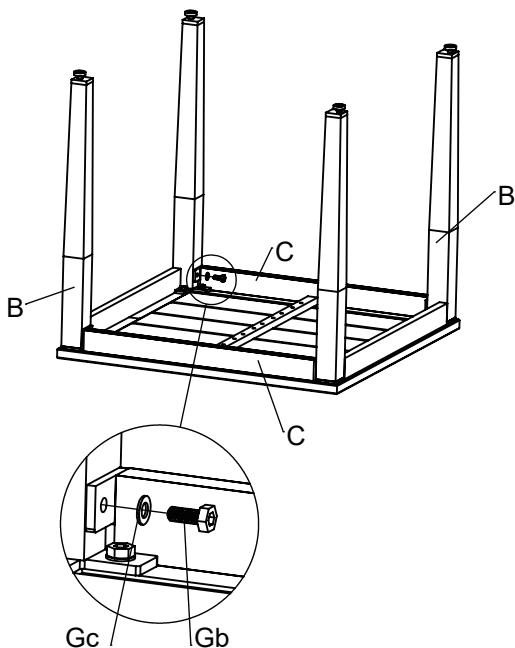

Gb x 4  
Bolt  
(Remove from the leg)



Gc x 4  
Metal washer  
(Remove from the leg)



Do not tighten completely.  
Repeat procedure for the other three legs.

3

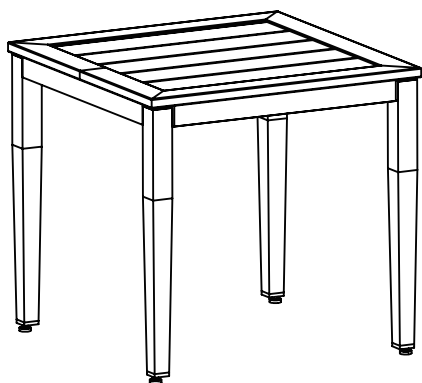

Turn over the side table, securely tighten all bolts by using Allen wrench (Gd) in a diagonal pattern.  
Adjust the table level by twisting knobs on the bottoms of the legs.

4

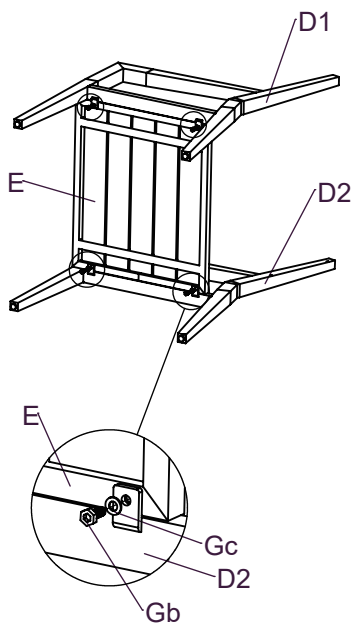

Gb x 4  
Bolt



Gc x 4  
Metal washer



Do not tighten completely.  
Repeat procedure for the other holes.

## Assembly instruction

5

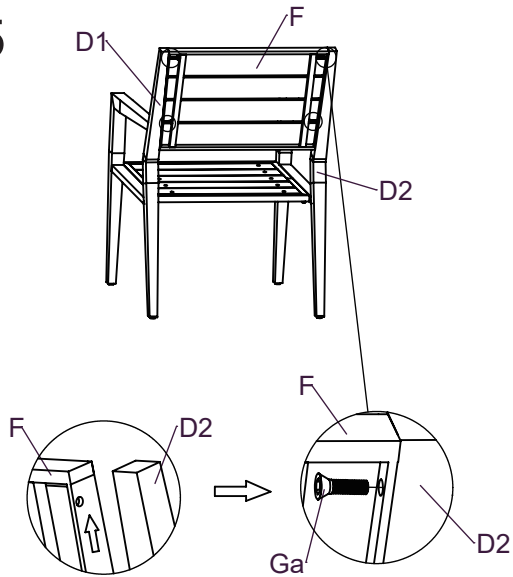

Ga x 4

Sunk screw



Note: the arrow points per drawing when assemble.  
Do not tighten completely.  
Repeat procedure for the other holes.

6

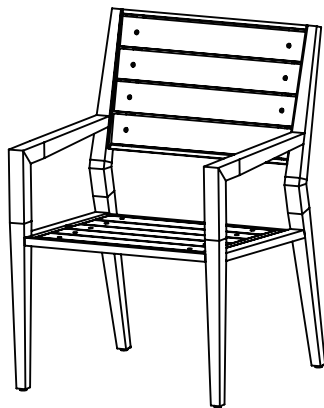

Once all bolts and screws are in place, go back and tighten all bolts and screws by using Allen wrench (Gd).

Repeat procedure for the other chair.

Now your seating set is ready for use!