

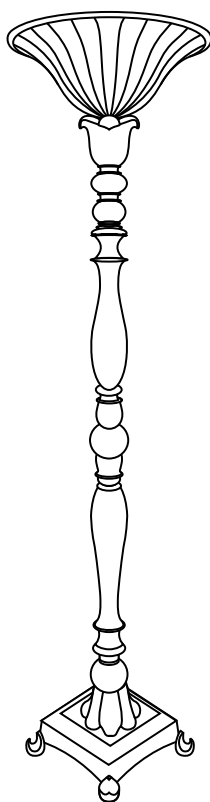

Item #
1000051637 / 1000050947
Model #
CA JD-AU10017 / JD-AU10017

USE AND CARE GUIDE

FLOOR LAMP



Questions, problems, missing parts? Before returning to the store,
call Hampton Bay Customer Service
8 a.m. - 7 p.m., EST, Monday-Friday and 9 a.m. - 6 p.m., EST, Saturday

1-855-HD-HAMPTON

HAMPTONBAY.COM

THANK YOU

We appreciate the trust and confidence you have placed in Hampton Bay through the purchase of this light fixture. We strive to continually create quality products designed to enhance your home. Visit us online to see our full line of products available for your home improvement needs. Thank you for choosing Hampton Bay!

Table of Contents

Table of Contents	2	Package Contents	4
Safety Information	2	Installation	5
Warranty	2	Operation	6
Pre-Installation	3	Care and Cleaning	6
Planning Installation	3	Troubleshooting	6
Hardware	3		

Safety Information

- Please read and understand this entire manual before attempting to assemble, operate or install the product.



CAUTION: If a dimmer control switch is used with this fixture, obtain professional advice to determine the correct type and electrical rating required.

CAUTION: Inspect the wire insulation for any cuts, abrasions, or exposed copper that may have resulted during shipping. If there is a defect in the wire, do not attempt installation. Please call our Customer Service Team at 1-855-HD-HAMPTON.



WARNING: Be careful not to damage or cut the wire insulation (covering) during fixture installation. Do not permit wires to contact any surface with a sharp edge. This may damage or cut the wire insulation, which could cause serious injury or death from electric shock.

Warranty

The manufacturer warrants this lighting fixture to be free from defects in materials and workmanship for a period of one (1) year from date of purchase. This warranty applies only to the original consumer purchaser and only to products used in normal use and service. If this product is found to be defective, the manufacturer's only obligation, and your exclusive remedy, is the repair or replacement of the product at the manufacturer's discretion, provided that the product has not been damaged through misuse, abuse, accident, modifications, alterations, neglect, or mishandling. This warranty shall not apply to any product that is found to have been improperly installed, set-up, or used in any way not in accordance with the instructions supplied with the product. This warranty shall not apply to a failure of the product as a result of an accident, misuse, abuse, negligence, alteration, faulty installation, or any other failure not relating to faulty material or workmanship. This warranty shall not apply to the finish on any portion of the product, such as surface and/or weathering, as this is considered normal wear and tear. The manufacturer does not warrant and specially disclaims any warranty, whether express or implied, of fitness for a particular purpose, other than the warranty contained herein. The manufacturer specifically disclaims any liability and shall not be liable for any consequential or incidental loss or damage, including but not limited to any labor / expense costs involved in the replacement or repair of said product.

Contact the Customer Service Team at 1-855-HD-HAMPTON or visit www.hamptonbay.com.

Pre-Installation

PLANNING INSTALLATION

- Before beginning assembly, installation or operation of this product, make sure all parts are present. Compare parts with the package contents list. If any part is missing or damaged, do not attempt to assemble, install or operate the product.
- Read all instructions before installation.
- To avoid damaging this product, assemble it on a soft, non-abrasive surface, such as carpet or cardboard.
- Keep your receipt and these instructions for proof of purchase.

HARDWARE INCLUDED



NOTE: Hardware not shown to actual size.



AA

Part	Description	Quantity
AA	Socket ring	1

Pre-Installation (continued)

PACKAGE CONTENTS

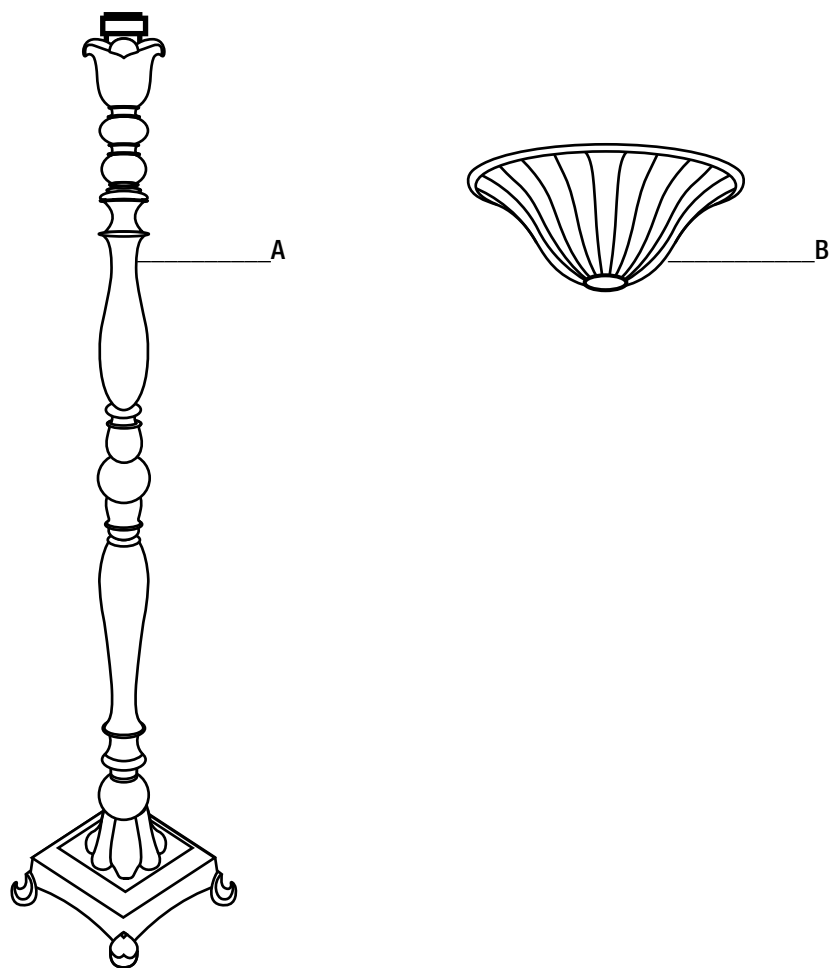

Part	Description	Quantity
A	Light fixture	1
B	Glass shade	1

Installation

1 ASSEMBLING THE LIGHT FIXTURE

- ❑ Assemble the poles of the light fixture (A) by screwing them together.
- ❑ Remove the pre-installed socket ring (AA), add the glass shade (B) and reinstall the socket ring (AA).

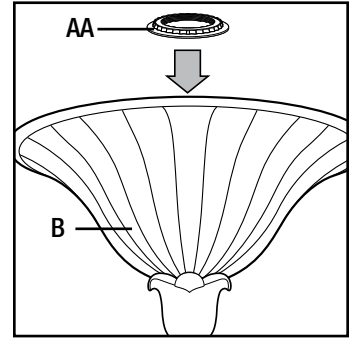
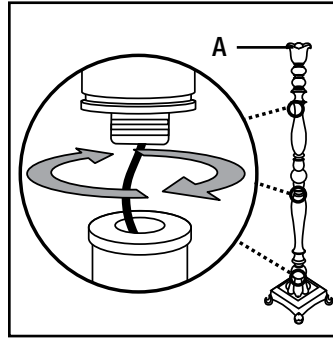

2 INSTALLING THE LIGHT BULB

- ❑ **MODEL #JD-AU10017:** Install one 150-watt max. medium-base incandescent bulb or one 23-watt max. CFL bulb (not included).
- ❑ **MODEL #CA JD-AU10017:** Install one 150-watt max. medium-base incandescent bulb (not included) or one 23-watt max. CFL bulb (included).

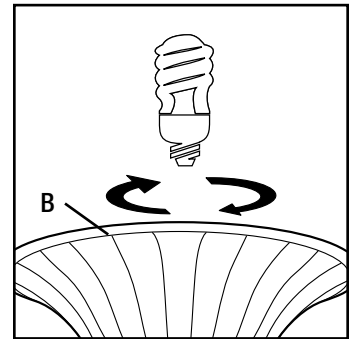
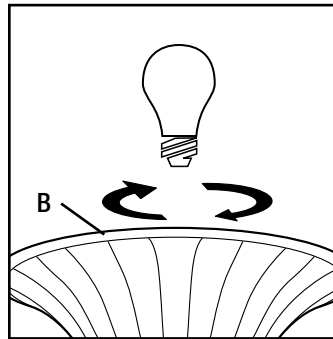

Lighting Facts		Per Bulb
Brightness	1600 lumens	
Estimated Yearly Energy Cost	\$2.77	
	Based on 3 hrs/day, 11¢/kWh Cost depends on rates and use	
Life	Based on 3 hrs/day 9.1 years	
Light Appearance	Warm ————— Cool ▲ 2700 K	
Energy Used	23 watts	
Contains Mercury	For more on clean up and safe disposal, visit epa.gov/cfl .	

Brightness
1600
lumens
Estimated Energy Cost
\$2.77
per year

Operation

1 TURNING THE LIGHT ON

- Turn the switch on the light fixture (A).

Care and Cleaning

- To clean, unplug the lamp and wipe with a damp, non-abrasive cloth.

Troubleshooting

Problem	Possible Cause	Solution
The light will not turn on.	The bulb is burned out.	Make sure the lamp is plugged in and power is on.
	The switch is bad.	Consult a certified electrician.



Questions, problems, missing parts? Before returning to the store,
call Hampton Bay Customer Service
8 a.m. - 7 p.m., EST, Monday-Friday and 9 a.m. - 6 p.m., EST, Saturday

1-855-HD-HAMPTON

HAMPTONBAY.COM

Retain this manual for future use.