

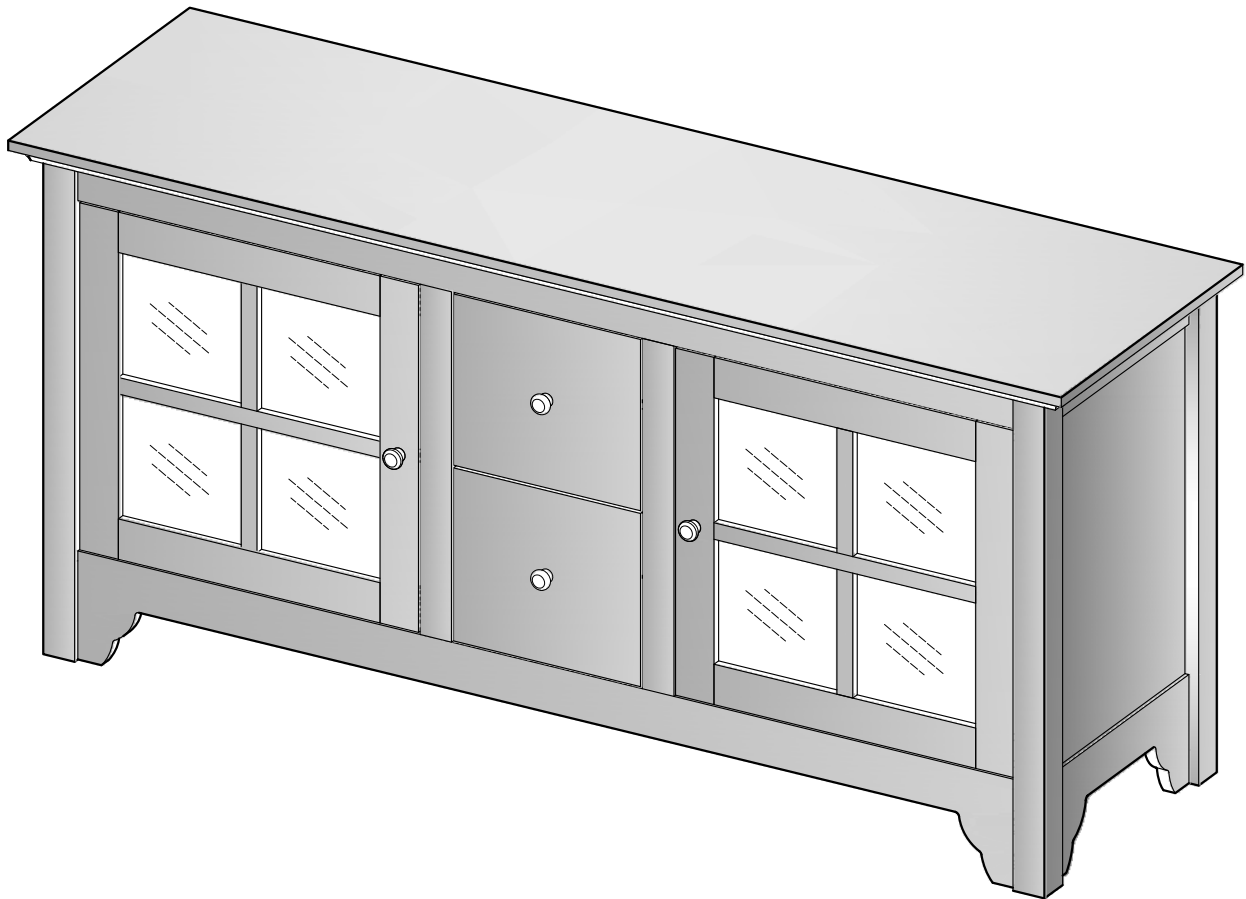

Walker
Edison

furniture company

Item #: W52C2DW
Assembly Instructions



For our most current instructions, to request missing, lost or broken parts, or for any other Customer Service issues, please visit our website at www.walkeredison.com or call us at 877-207-5906.

Revised 04/2012

General Assembly Guidelines

- I. Insure that all parts and hardware are available before beginning assembly.
- II. Follow each step carefully to Insure the proper assembly of this product.
- III. Two people are recommended for ease in the assembly of this product.
- IV. The main types of hardware used to assemble this product are wood dowels, cam bolts and locks, bolts and screws.
- V. The provided glue is to secure wood dowels in place. When first inserting dowels, locate the appropriate hole for the dowel, place a small amount of glue in the hole and insert the dowel. Wipe away excess glue immediately.

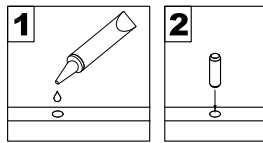

In future assembly steps when dowels are necessary to attach assembly parts together, place a small amount of glue on the end of the dowel before attaching parts together. Wipe away excess glue immediately.

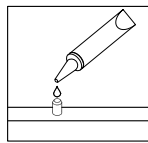

- VI. A Phillips head screwdriver is required for the assembly of this product.

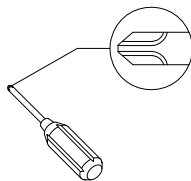



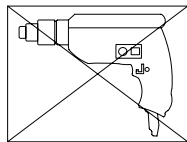



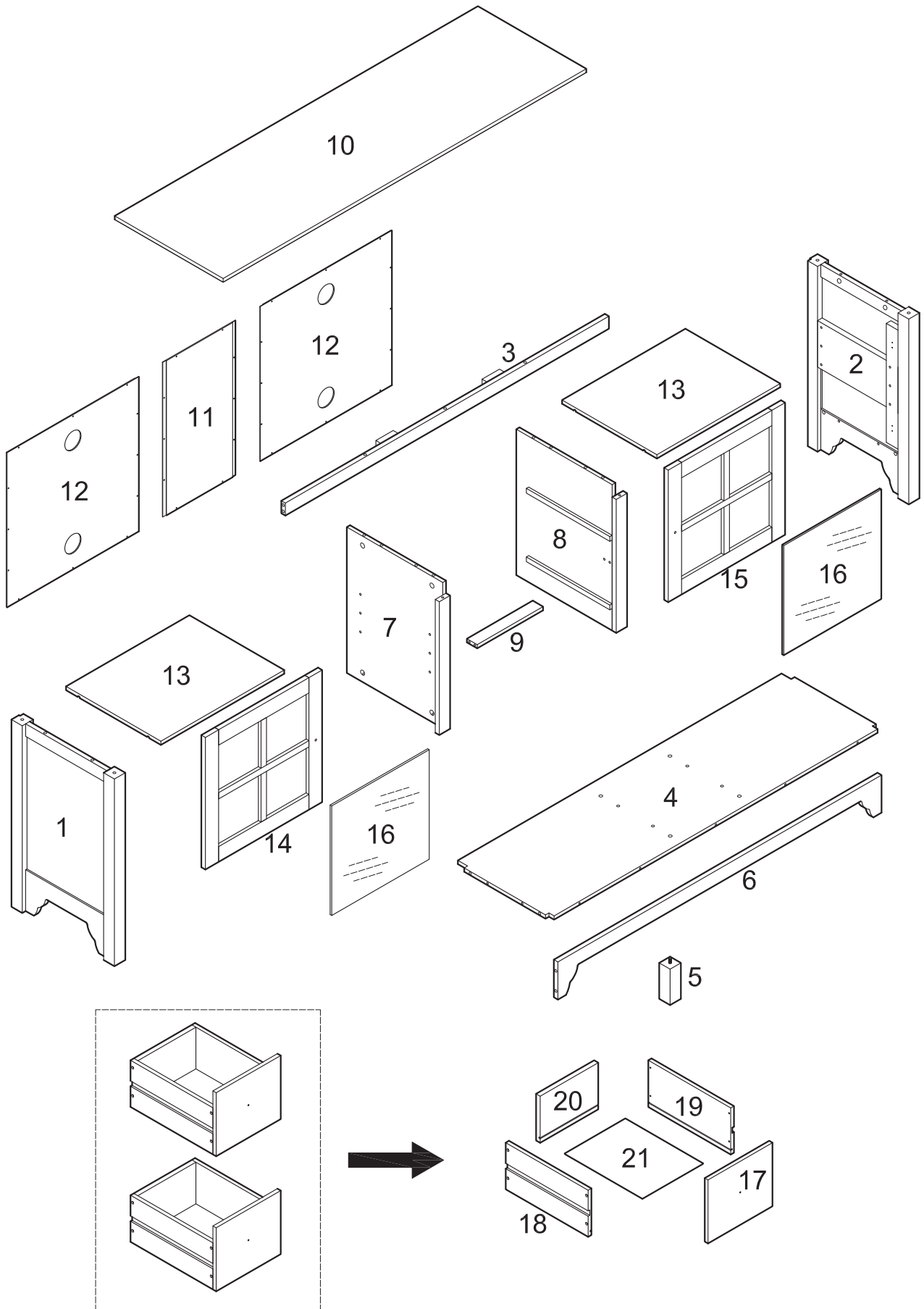





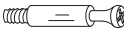





- VII. Power tools should not be used to assemble this product.



Parts List

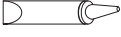

Hardware List

A		Ø8x30	Large wood dowel	10 pcs
B		Ø6x30	Small wood dowel	20 pcs
C		Ø6x32	Cam bolt	21 pcs
D		Ø8x30mm	Cam bolt	3 pcs
E		Ø15x9.5	Cam lock	24 pcs
F		Ø7x2.5x12	Screw	28 pcs
G		Ø8x5x16	Shelf support pin	8 pcs
H		Ø24x21	Handle	4 pcs
J		Ø9x5/32"x3/4"	Bolt	4 pcs
K		Ø12x0.5	Metal washer	16 pcs
L			Hinge	4 pcs
M			Shelf stopper	2 pcs
N		Ø6.5x3.5x12	Screw	16 pcs
P		Ø6x3x12	Screw	2 pcs
Q		Ø4x2x8	Screw	16 pcs
R		Ø8x4x25	Screw	16 pcs
S			Glue tube	1 pc
T			Touch-up marker	1 pc

*The hardware quantities listed above are required for proper assembly.
Some extra hardware may also have been included.*

Step 1

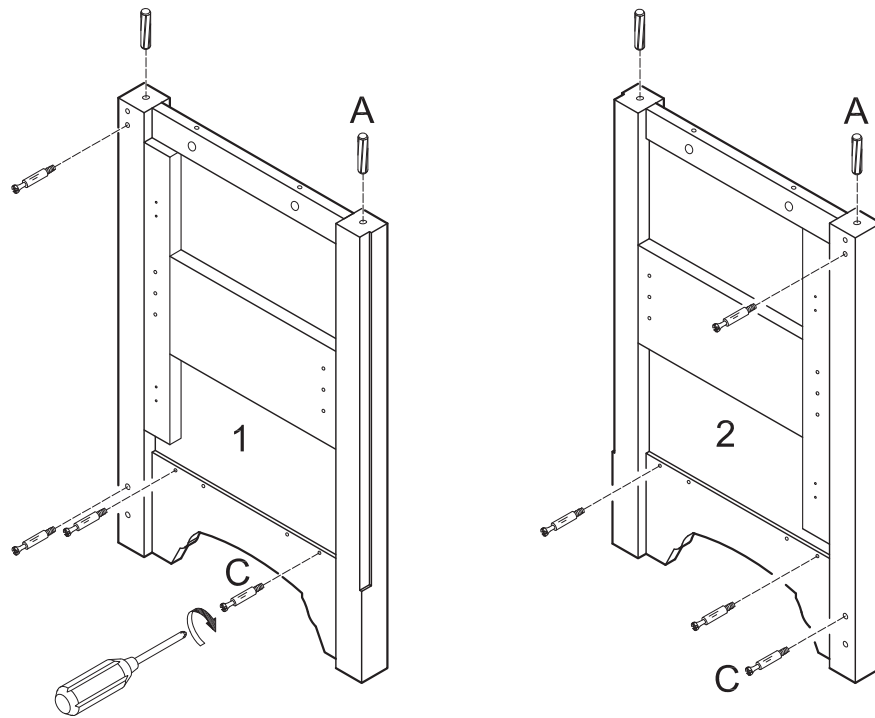

Insert large dowels (A) into panels (1,2). Screw cam bolts (C) into panels (1,2).

Step 2

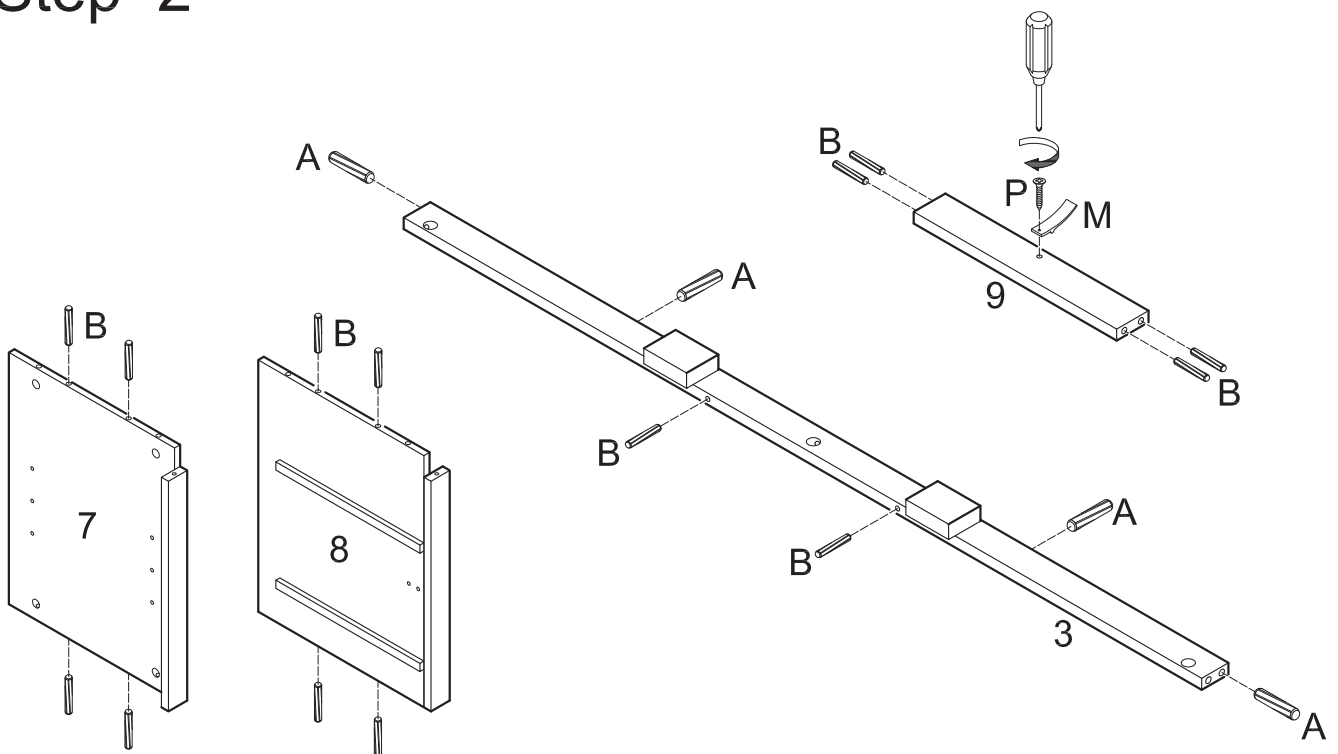

Insert small dowels (B) into panels (7,8) and slats (3,9). Insert large dowels (A) into slat (3). Attach drawer stopper (M) to slat (9) using screw (P).

Step 3

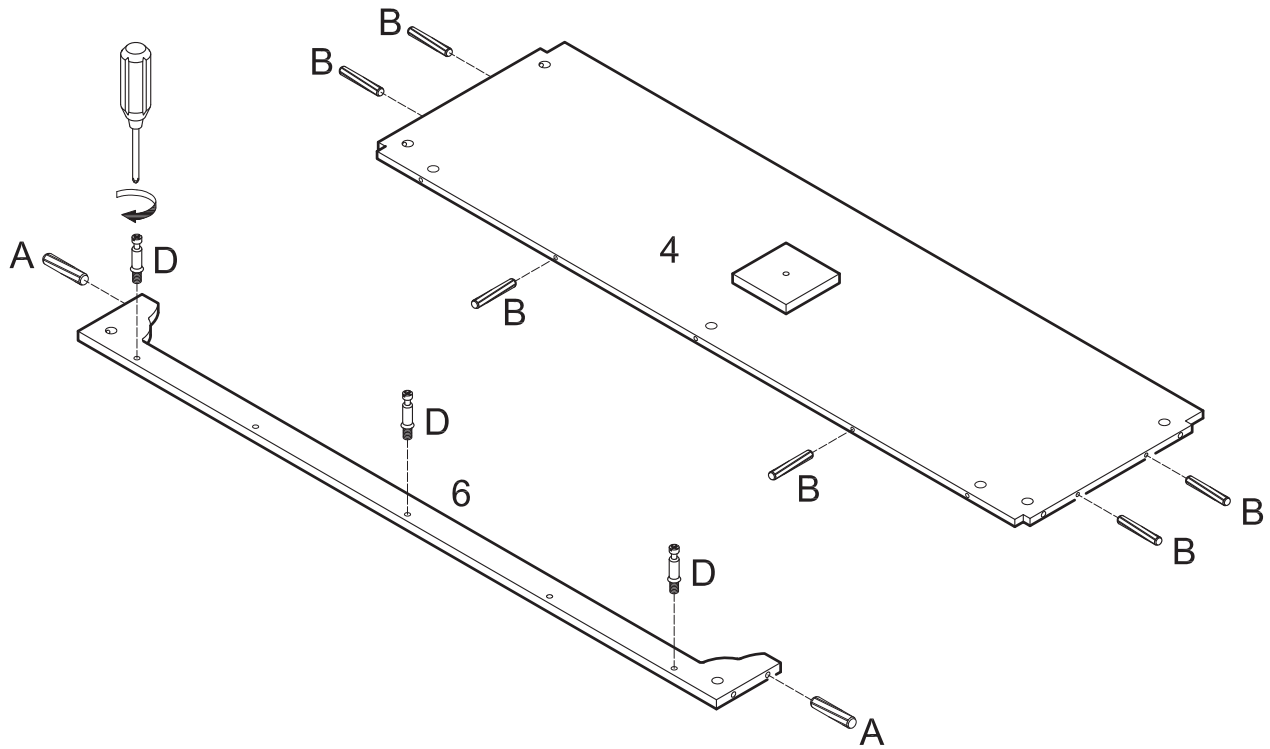

Insert large dowels (A) into slat (6). Screw cam bolts (D) into slat (6). Insert small dowels (B) into panel (4).

Step 4

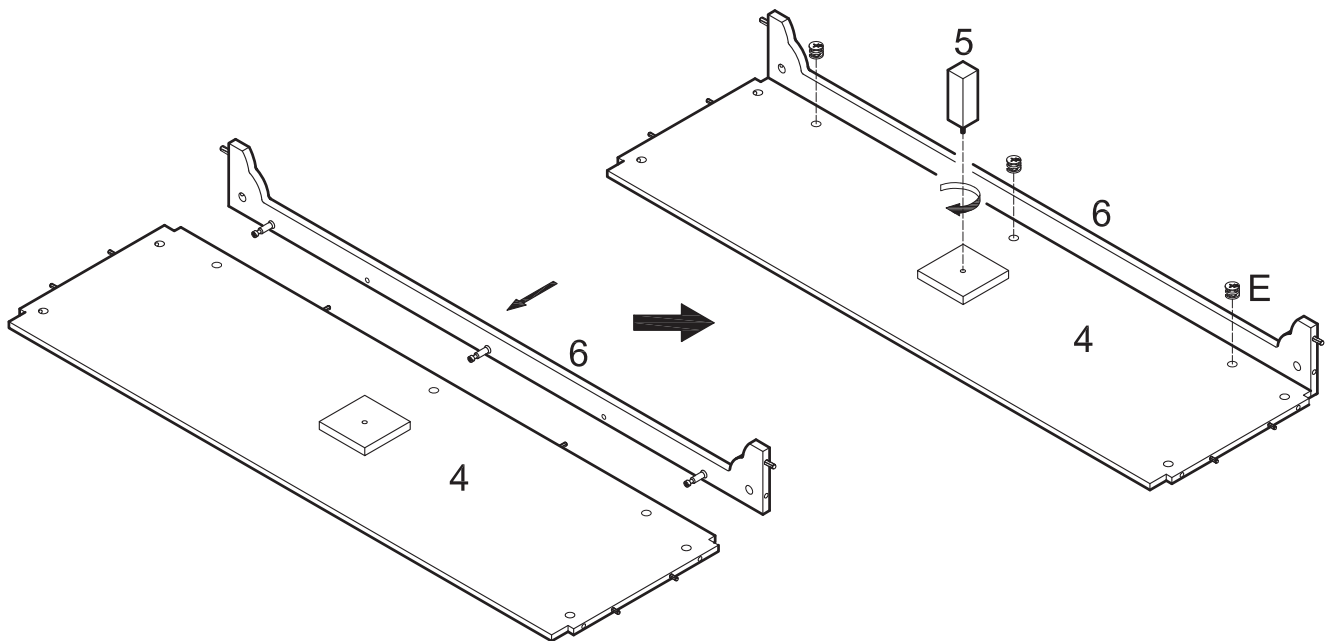
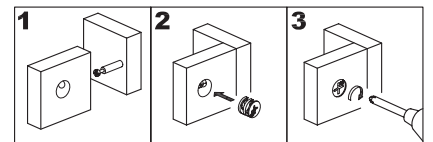

Attach slat (6) to panel (4) using cam bolts and dowels as guides. Insert cam locks (E) into panel (4) and tighten with a screwdriver. Screw leg (5) into panel (4).

Step 5

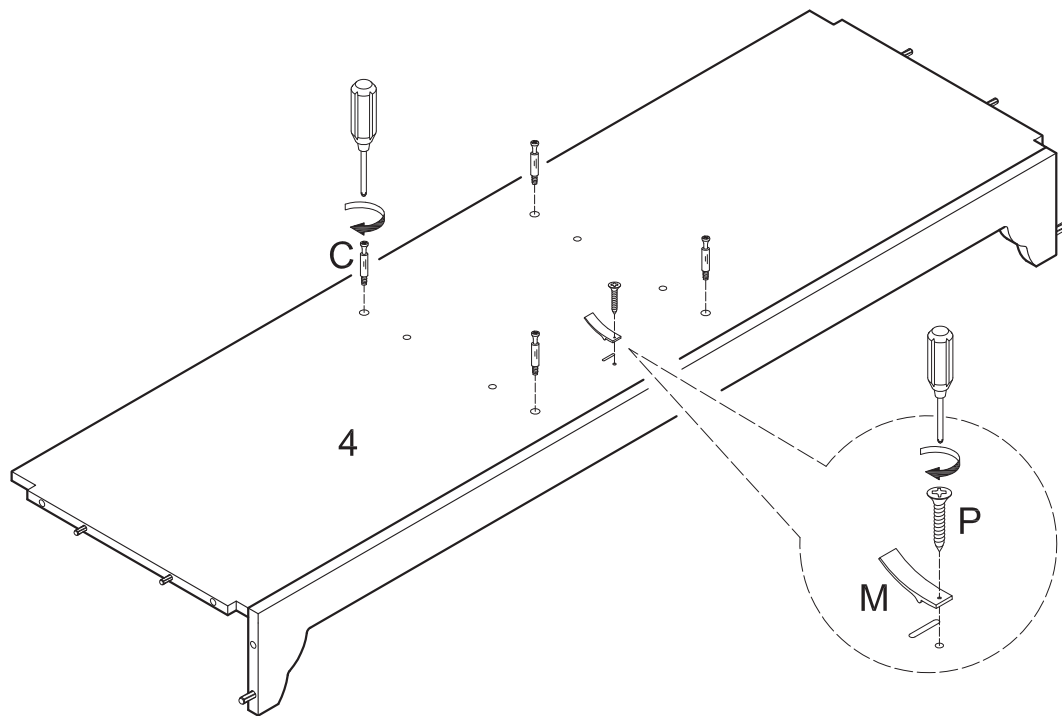

Screw cam bolts (C) into panel (4). Attach drawer stopper (M) to panel (4) using screw (P).

Step 6

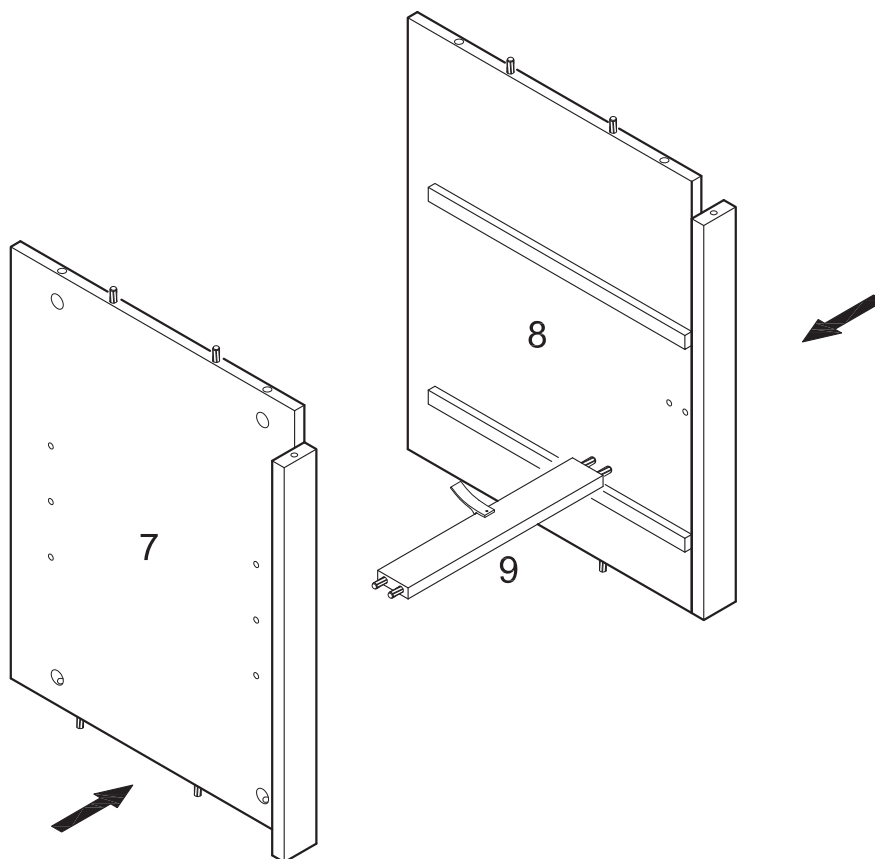

Join panels (7,8) together with slat (9) using dowels as guides.

Step 7

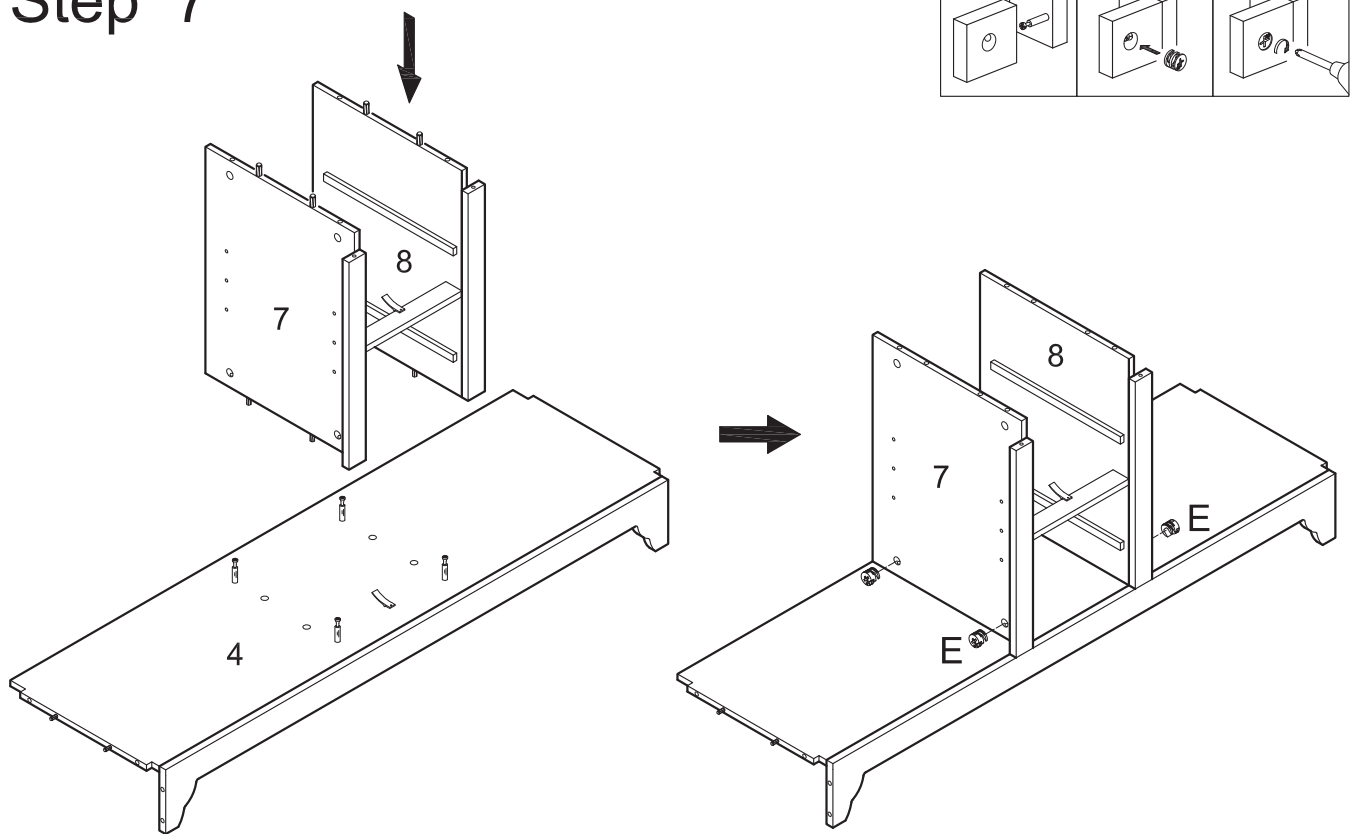

Attach panel assembly (7,8) to panel (4) using cam bolts and dowels as guides. Insert cam locks (E) into panels (7,8) and tighten with a screwdriver. *Two cam locks (E) will be inserted into each panel (7,8).*

Step 8

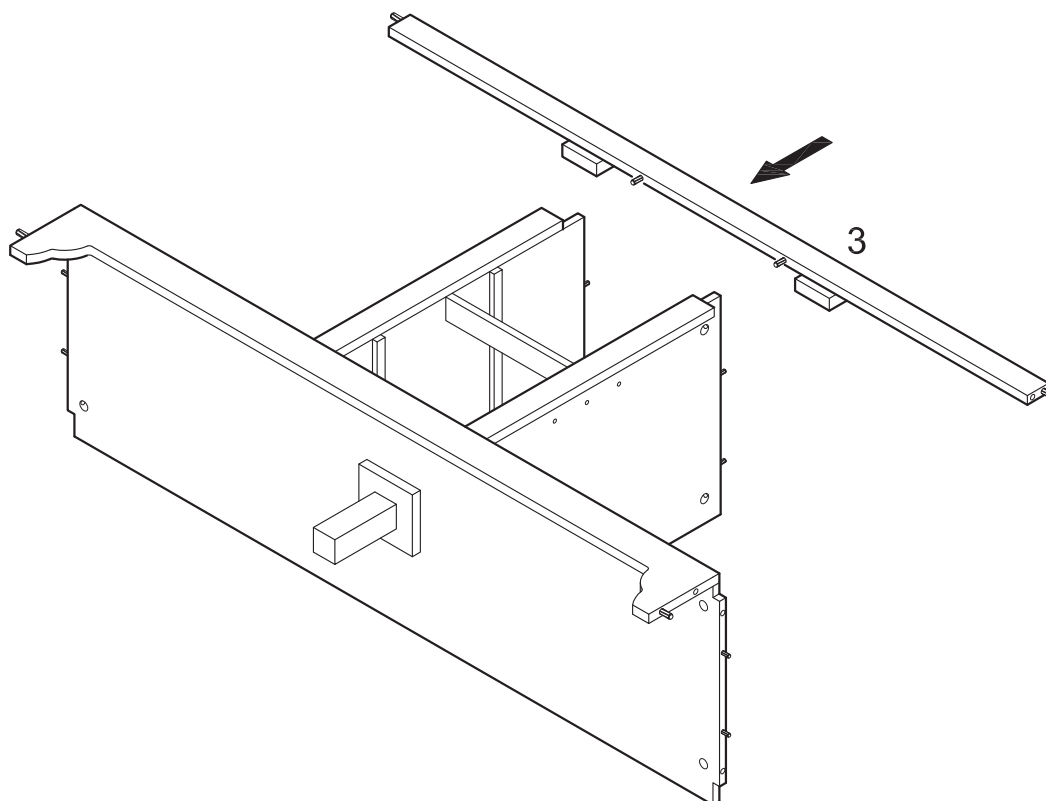

Attach slat (3) to the stand assembly using dowels as guides.

Step 9

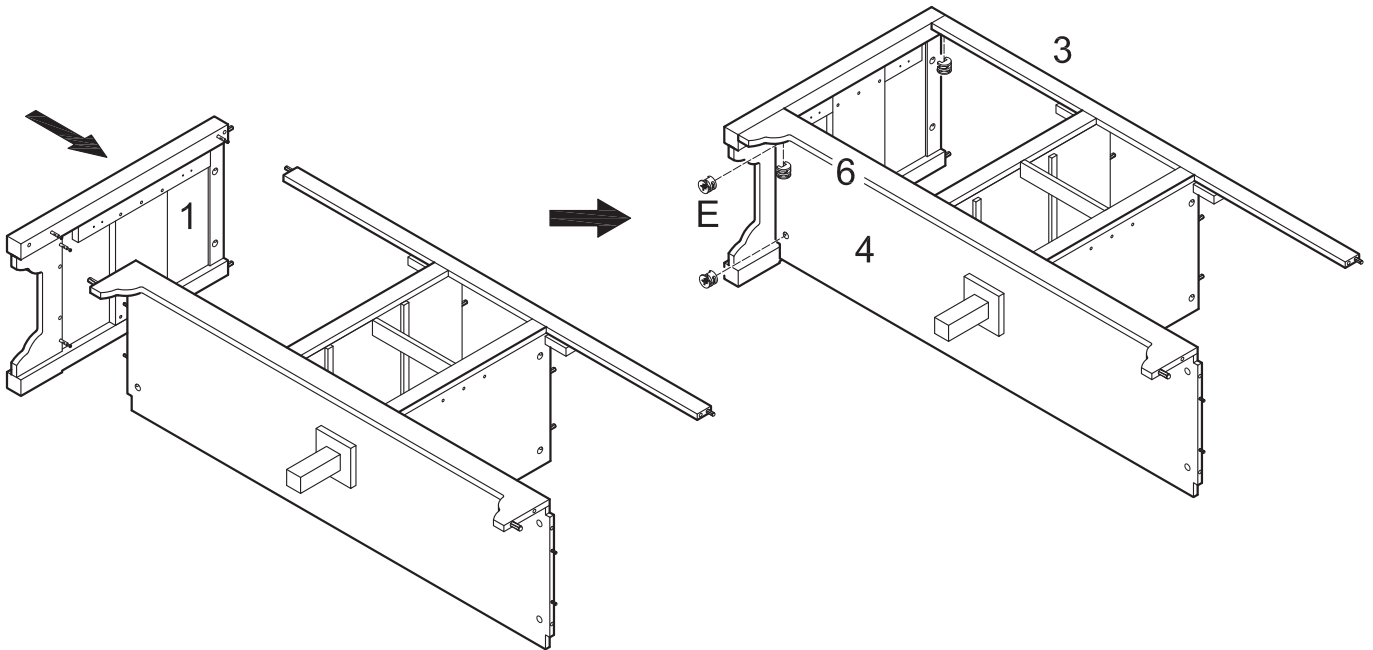
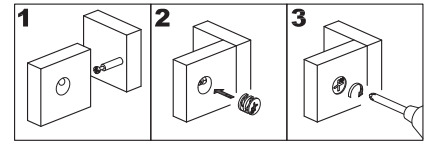

Attach panel (1) to the stand assembly using cam bolts and dowels as guides. Insert cam locks (E) into panel (4) and slats (3,6) and tighten with a screwdriver.

Step 10

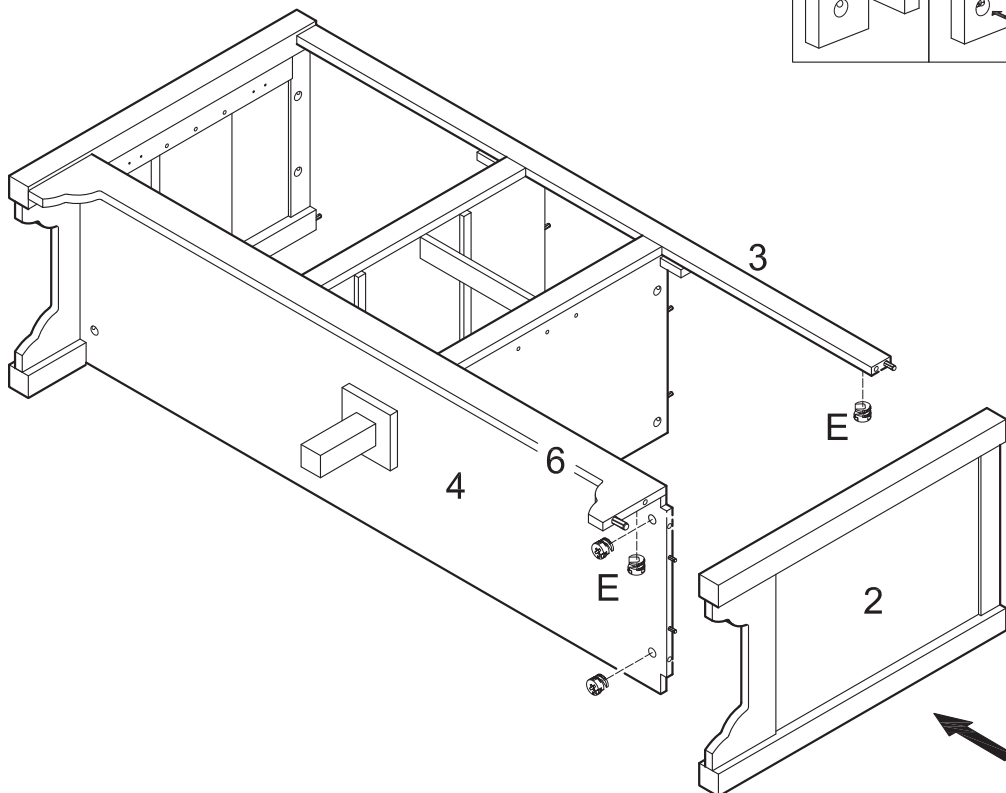
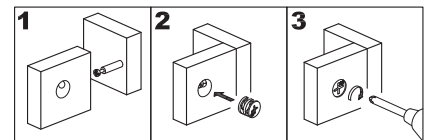

Attach panel (2) to the opposite side of the stand assembly using cam bolts and dowels as guides. Insert cam locks (E) into panel (4) and slats (3,6) and tighten with a screwdriver.

Step 11

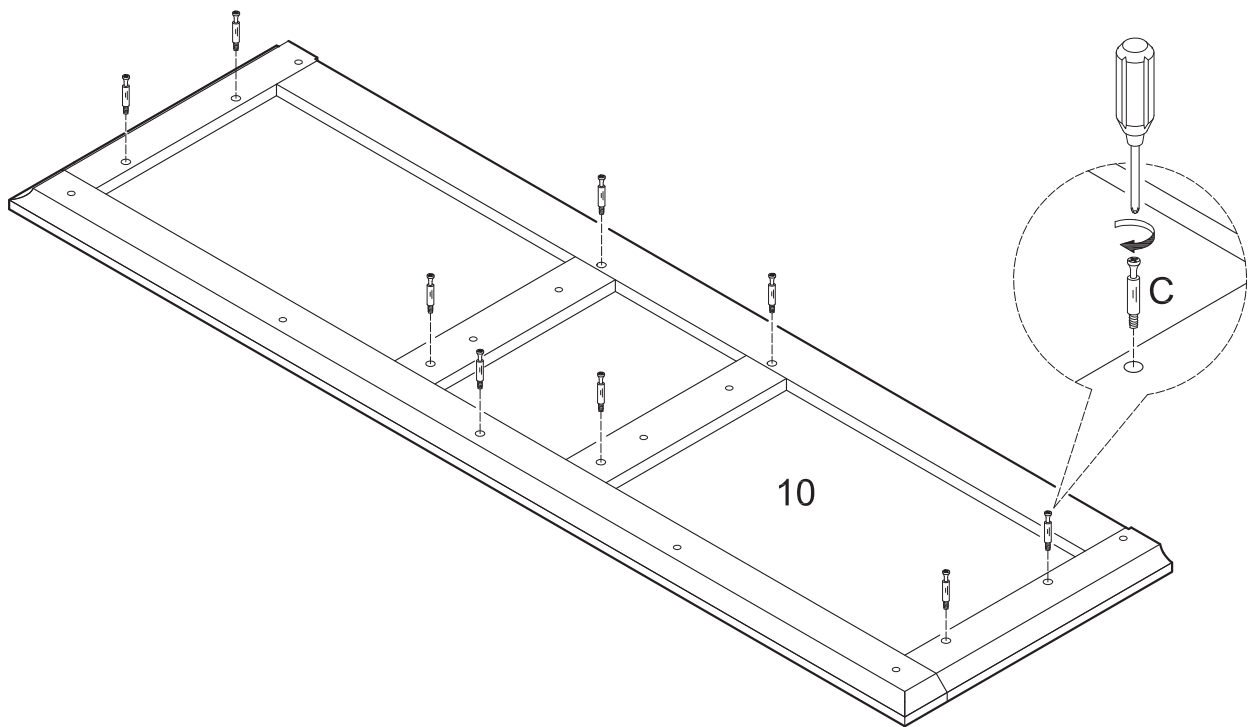

Screw cam bolts (C) into panel (10).

Step 12

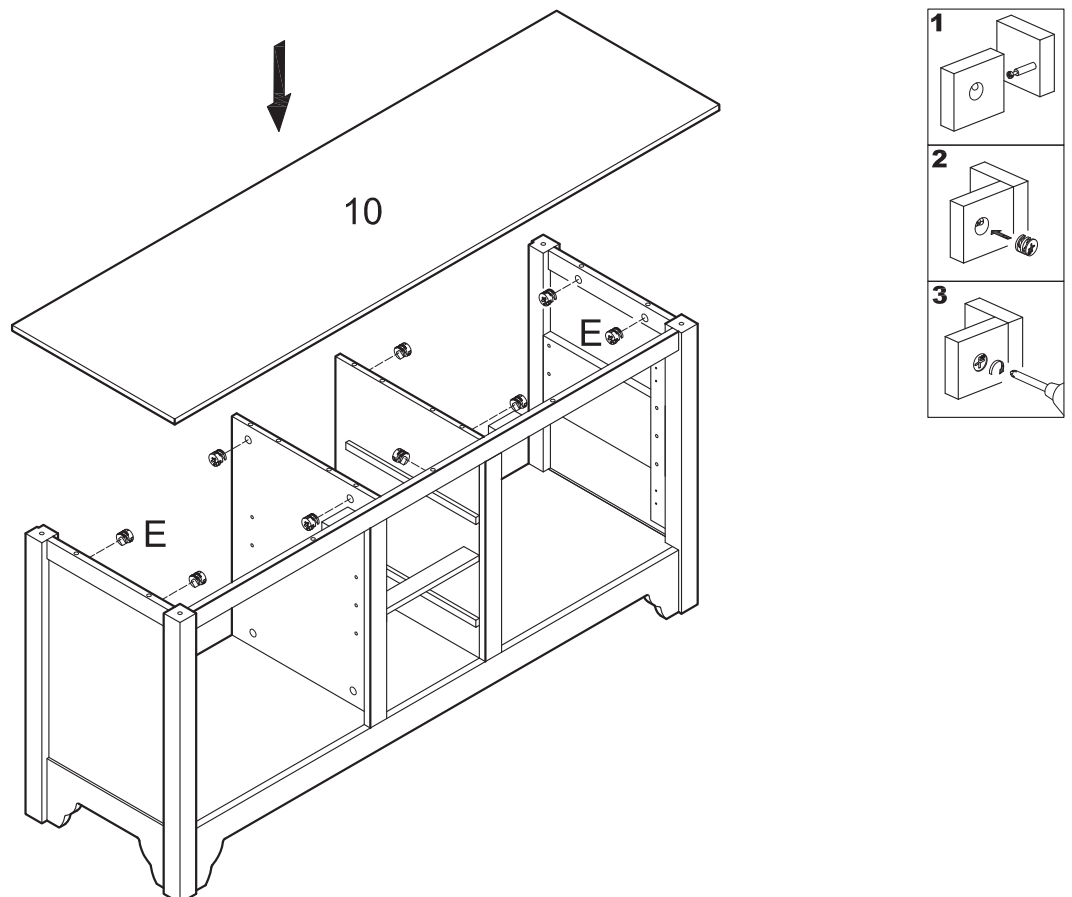

Insert cam locks (E) into the stand assembly as shown above. Attach top panel (10) to the stand assembly using cam bolts and dowels as guides. Tighten cam locks (E) with a screwdriver.

Step 13

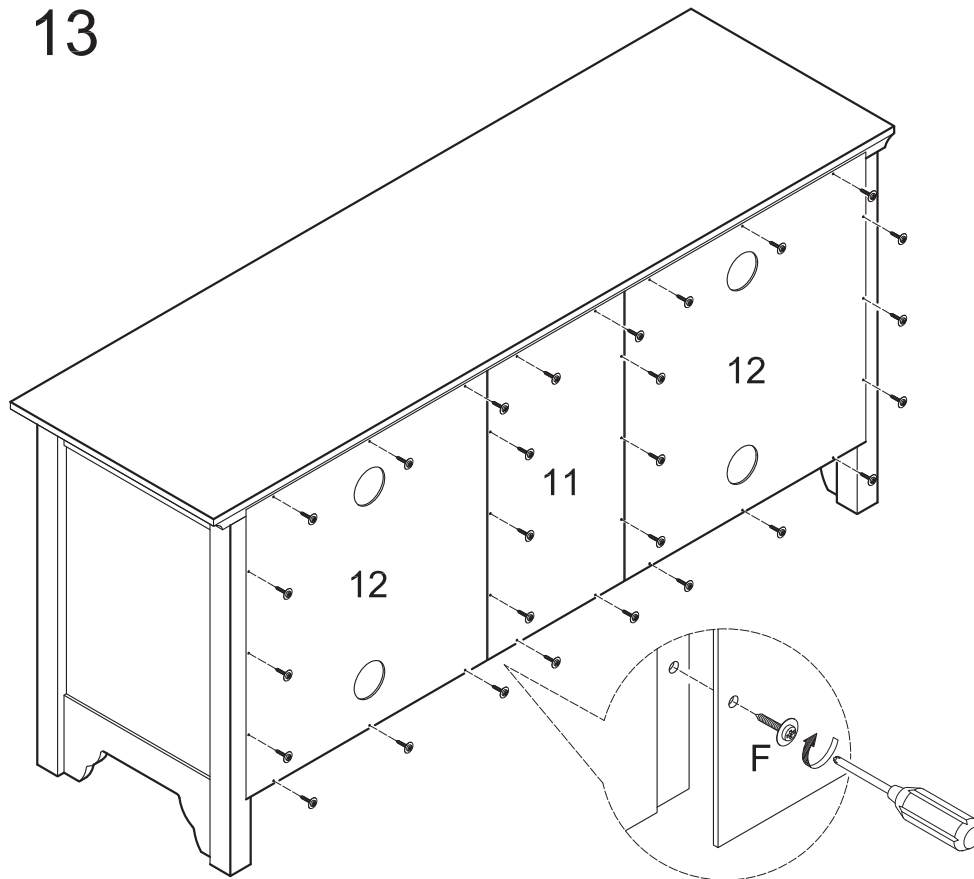

Attach panels (11,12) to the back of the stand assembly using screws (F). Note that panels (12) will overlap panel (11).

Step 14

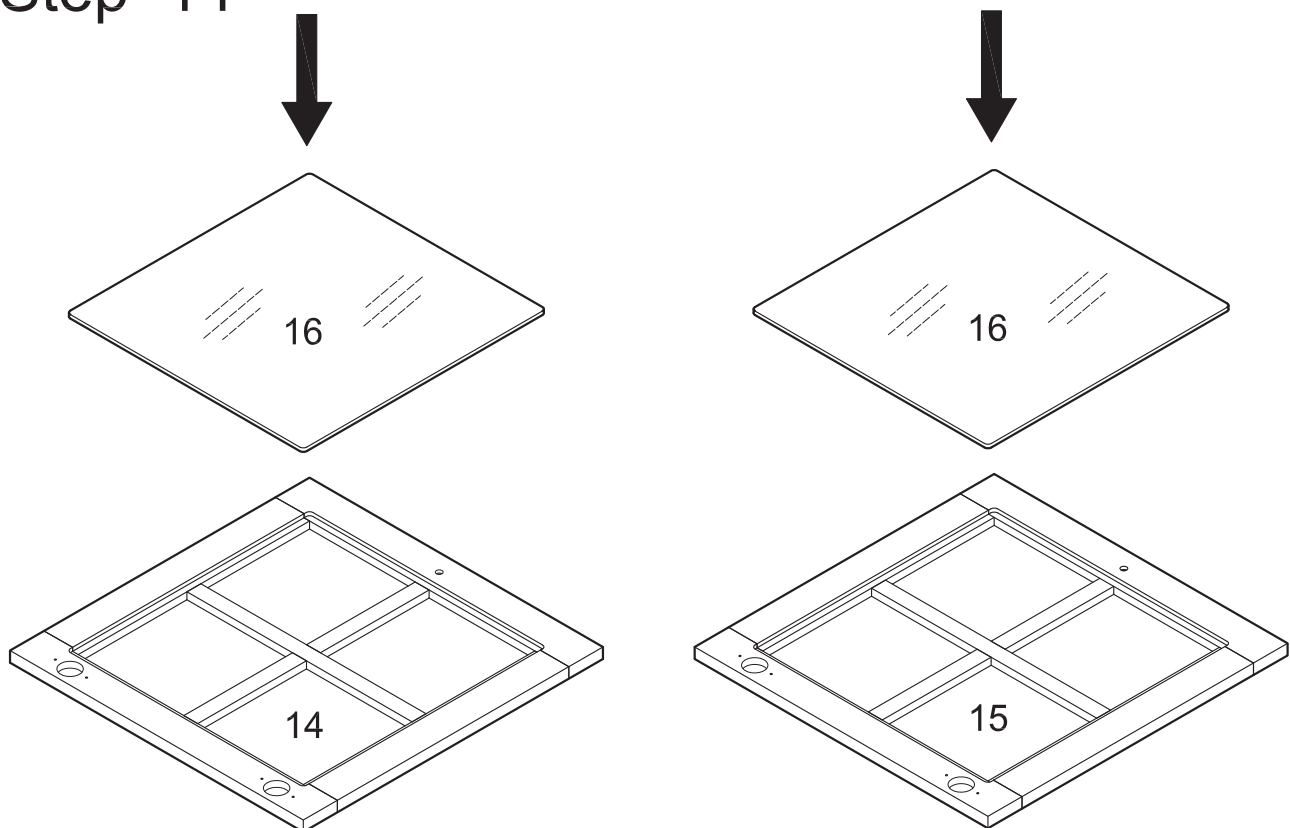

Carefully place glass panes (16) into door frames (14,15).

Step 15

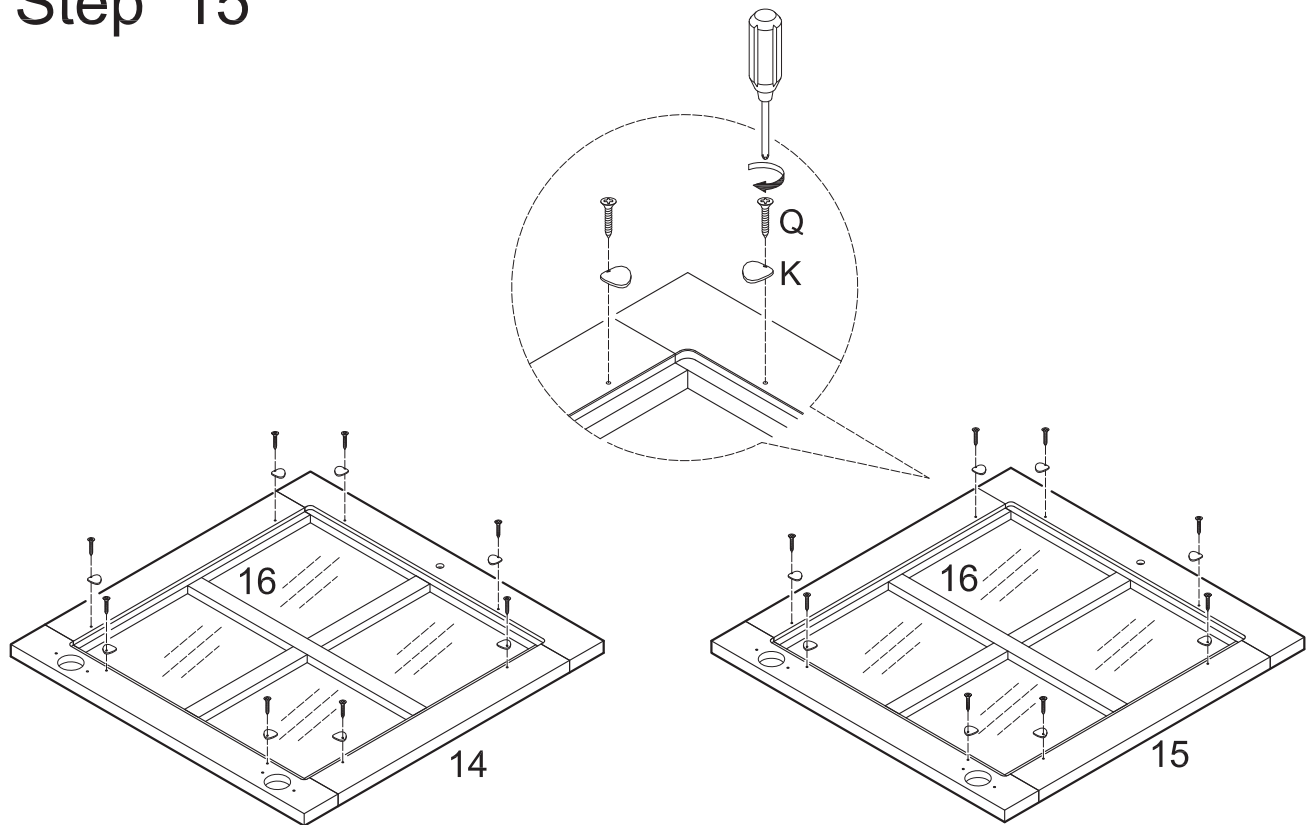

Secure glass panes (16) by attaching metal washers (K) to door frames (14,15) with screws (Q). *The curve of metal washers (K) will arc into glass panes (16).*

Step 16

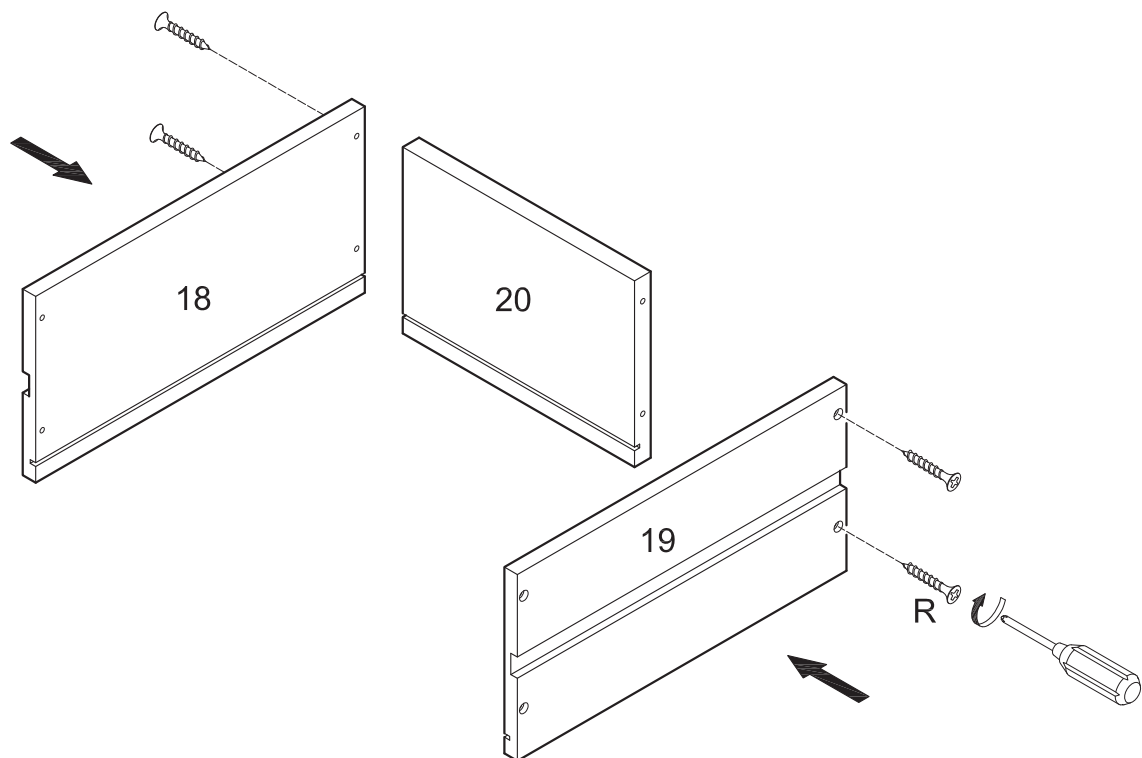

Attach drawer sides (18,19) to drawer back (20) using screws (R). *The thin grooves at the base of each drawer piece will align along the interior of the drawer assembly.* Repeat this step for the second drawer.

Step 17

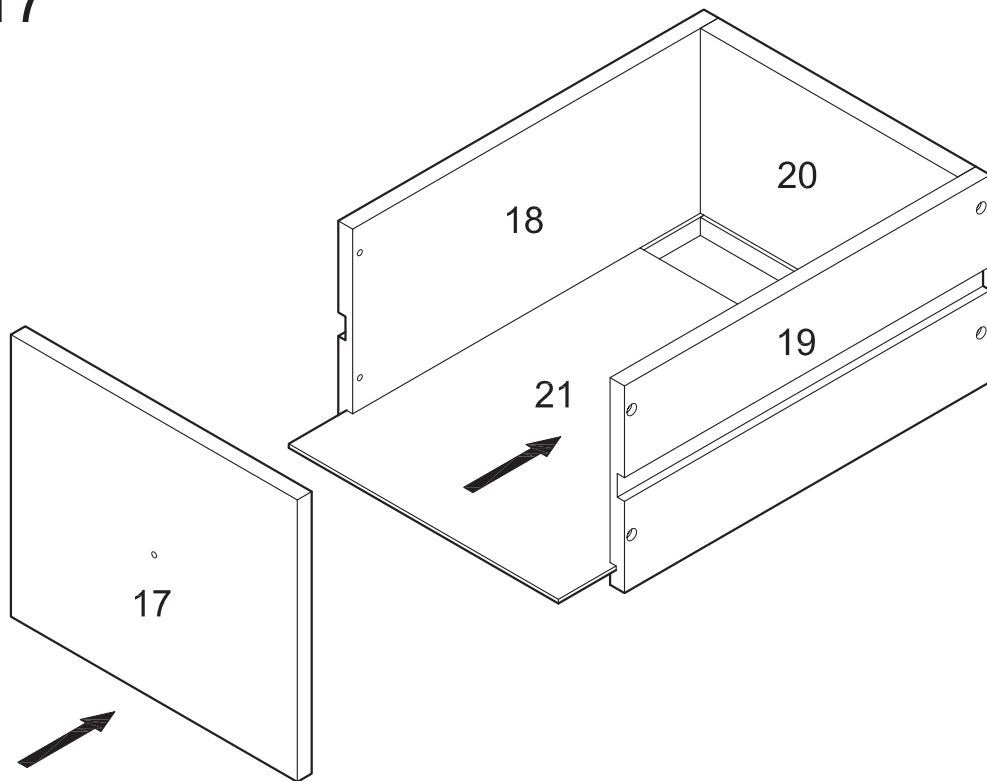

Slide drawer bottom (21) into place along the thin grooves of the drawer assembly. Fit drawer front (17) into place. Repeat this step for the second drawer.

Step 18

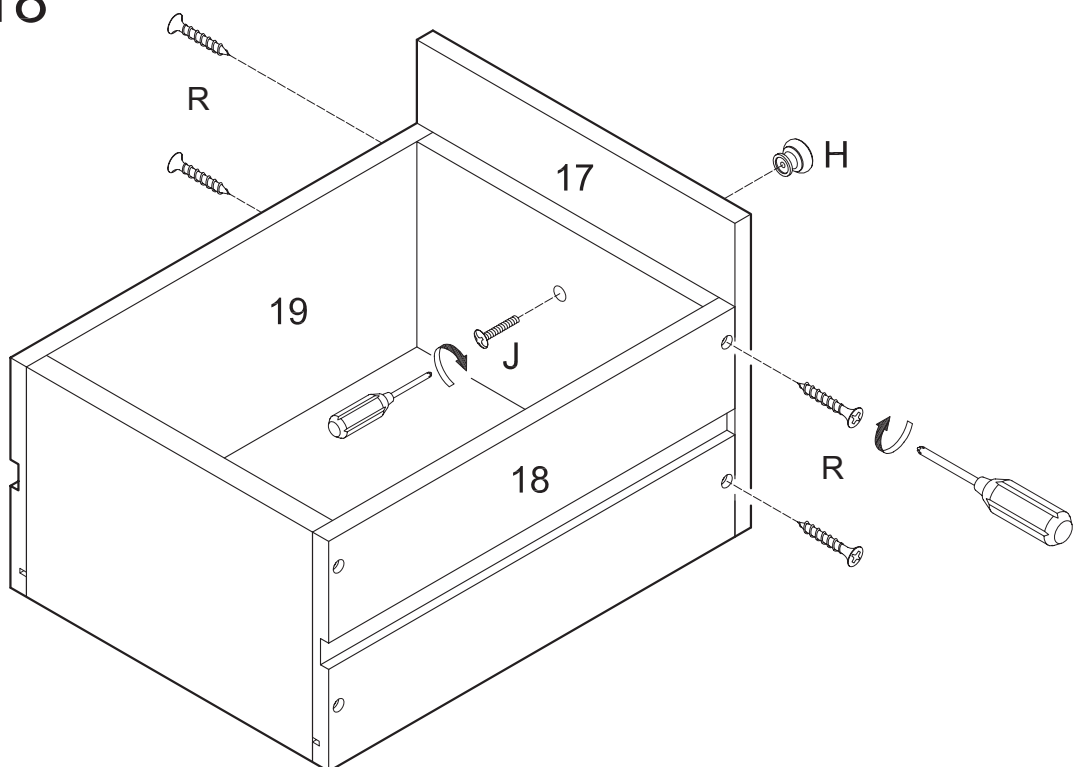

Secure drawer front (17) to the drawer assembly using screws (R). Attach handle (H) to drawer front (17) using bolt (J). Repeat this step for the second drawer.

Step 19

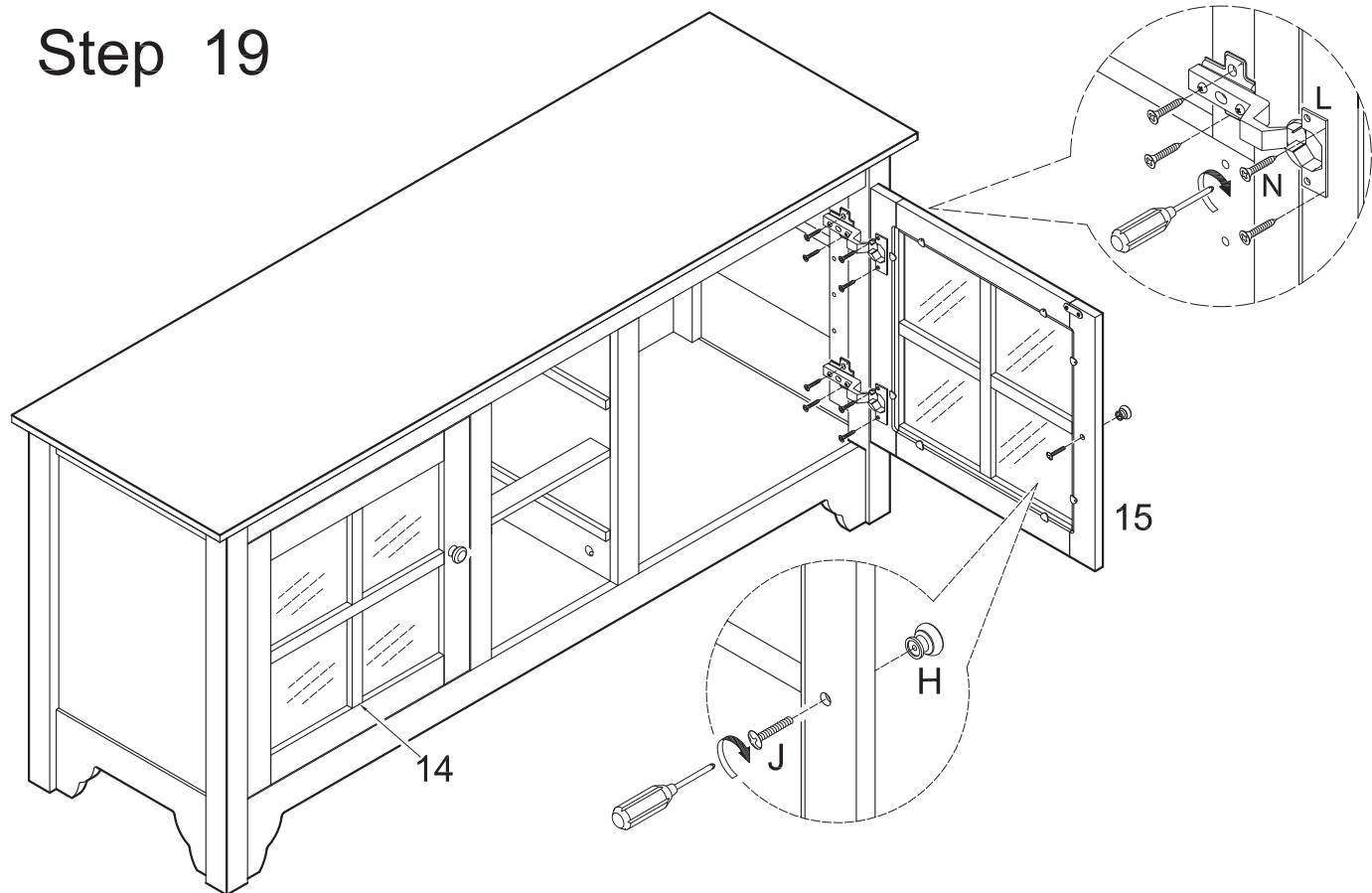

Attach hinges (L) to the interior of the assembly, then to doors (14,15) using screws (N). Attach handles (H) to doors (14,15) using bolts (J).

Step 20

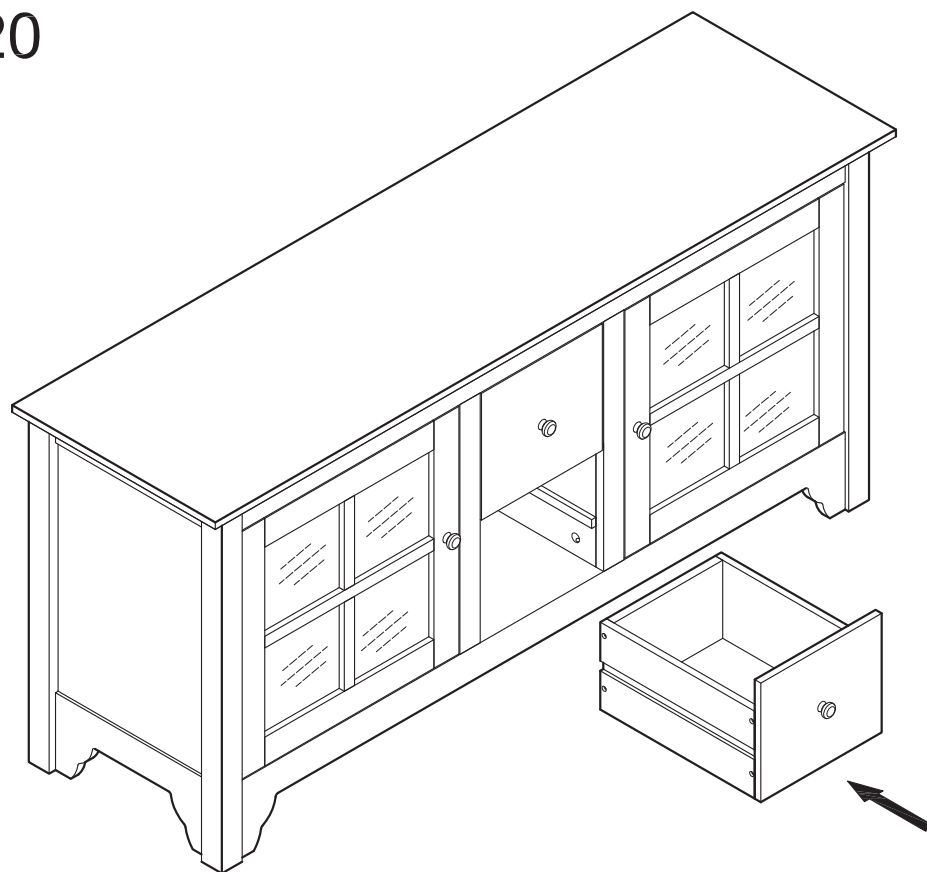

Carefully slide both drawers into the stand assembly.

Step 21

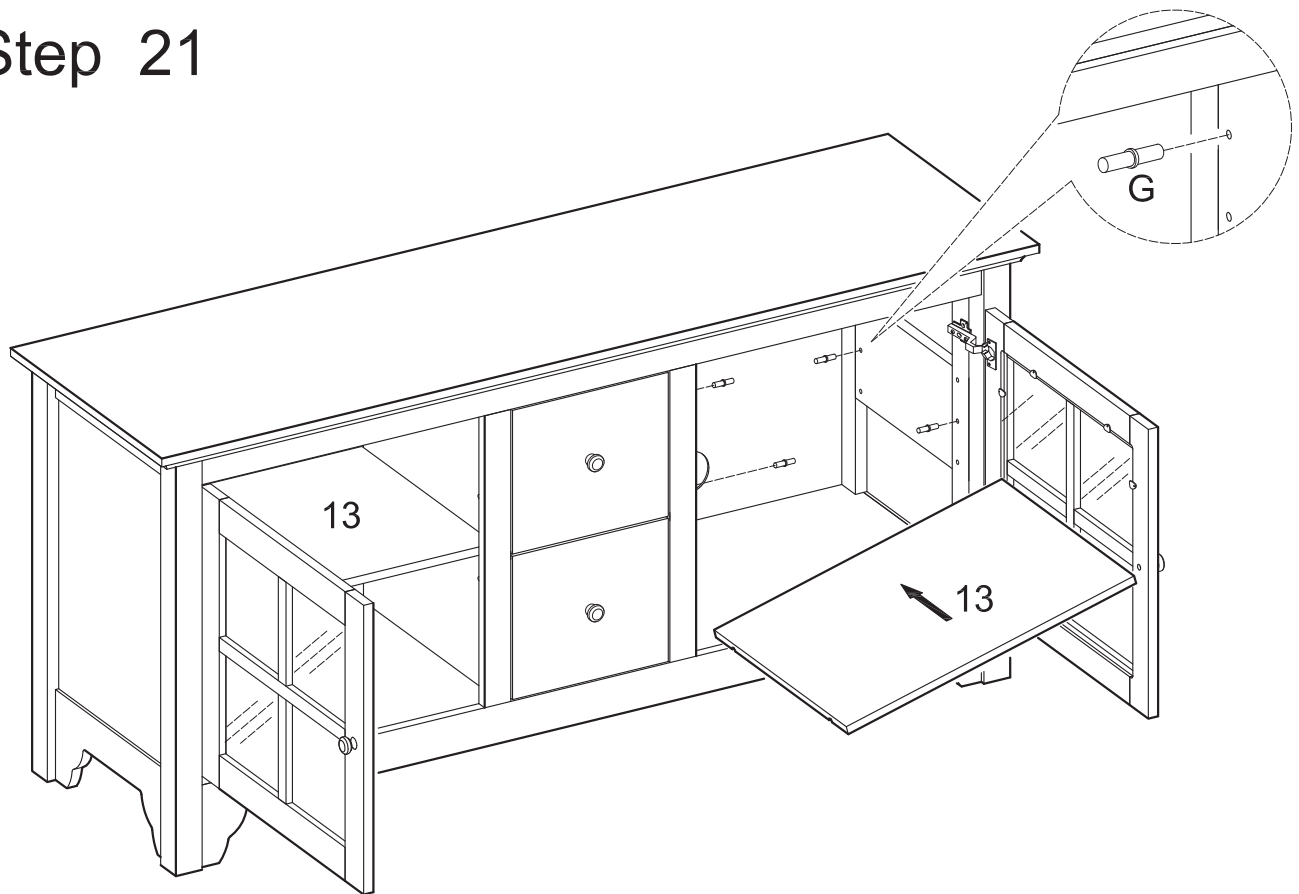

Insert shelf support pins (G) into the stand assembly at desired shelf heights. Place shelves (13) on shelf support pins (G).

Step 22

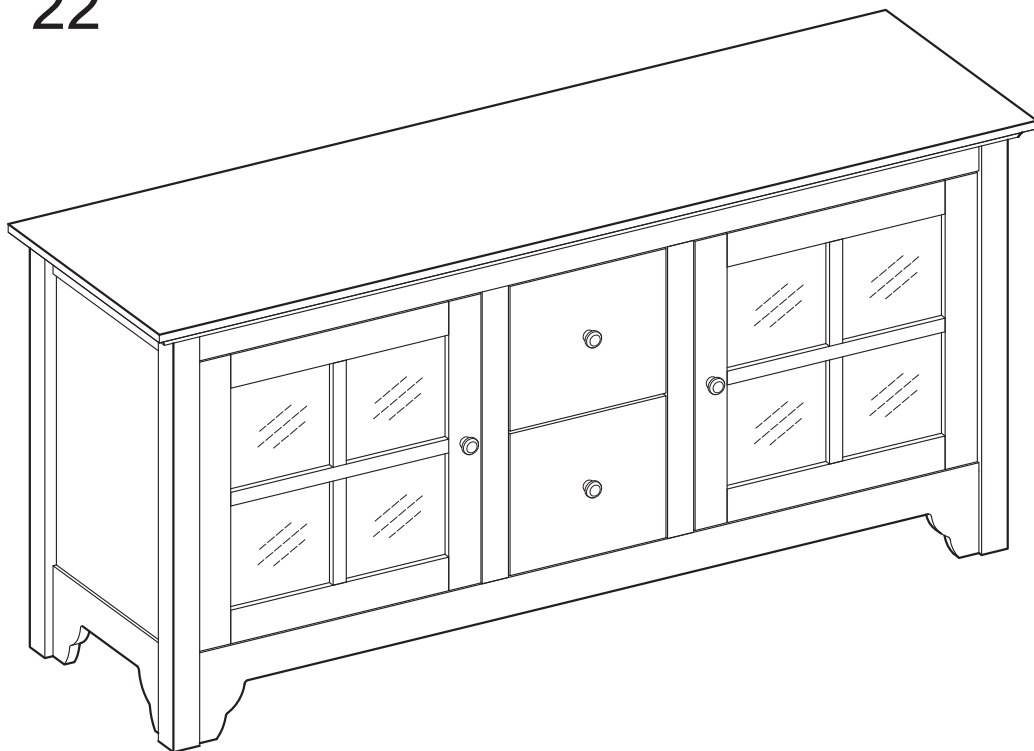

Final Assembly