



OPERATOR'S MANUAL

MODEL #100379
FRONT TINE TILLER



REGISTER YOUR PRODUCT ONLINE

at championpowerequipment.com



1-877-338-0999

or visit championpowerequipment.com

READ AND SAVE THIS MANUAL. This manual contains important safety precautions which should be read and understood before operating the product. Failure to do so could result in serious injury. This manual should remain with the product.
Specifications, descriptions and illustrations in this manual are as accurate as known at the time of publication, but are subject to change without notice.

TABLE OF CONTENTS

| | | | |
|--|-----------|--|-----------|
| Introduction | 3 | Maintenance | 20 |
| Safety Definitions | 3 | Tiller Lubrication | 21 |
| Important Safety Instructions | 4 | Check for Oil Leaks | 21 |
| Training | 4 | Check Hardware | 22 |
| Preparation | 4 | Tines | 22 |
| Operation | 4 | Checking and Adjusting the Tine Drive Belt Tension | 22 |
| Maintenance and Storage | 5 | Belt Tension Adjustment | 23 |
| Fuel Safety | 6 | Change Forward/Reverse Tine Drive Belts | 23 |
| Safety Symbols | 7 | Engine Cleaning | 24 |
| Operation Symbols | 9 | Air Cleaner Service | 24 |
| Quickstart Label Symbols | 9 | Engine Oil Service | 24 |
| Safety Labels | 10 | Air Cleaner Maintenance | 25 |
| Controls and Features | 11 | Spark Plug Service | 26 |
| Tiller | 11 | Spark Arrester Screen Service | 26 |
| Engine | 11 | Transportation and Storage | 26 |
| Assembly | 13 | Off-Season Storage | 26 |
| Unpacking | 13 | Removing from Storage | 27 |
| Install Lower Handle | 13 | Specifications | 28 |
| Install Upper Handle | 13 | Tiller Specifications | 28 |
| Install the Guard Extension | 13 | Engine Specifications | 28 |
| Install the Outer Tines | 13 | Fuel Specifications | 28 |
| Add Engine Oil | 14 | Parts Diagram | 29 |
| Add Fuel | 14 | Parts List | 30 |
| Forward Tine Control Lever | 15 | Engine Parts Diagram | 32 |
| Reverse Tine Control Lever | 15 | Engine Parts List | 33 |
| Depth Regulator Lever Adjustment | 15 | Troubleshooting | 35 |
| Transport Wheel Height Adjustment | 16 | Difficulty Starting Engine (Recoil) | 36 |
| Operation | 16 | Gasoline Engine: No Power | 37 |
| Introduction | 16 | Gasoline Engine Running Roughly | 37 |
| Starting the Engine | 17 | Stops Suddenly When Running | 38 |
| Stopping the Engine and the Tiller | 18 | Engine is Overheating | 38 |
| Operation at High Altitude | 18 | | |
| Tilling Tips and Techniques | 18 | | |
| Tilling Depths | 18 | | |
| Choosing Correct Tine Speed | 19 | | |
| Avoid Tilling Soggy, Wet Soil | 19 | | |
| Preparing Seedbeds | 19 | | |
| Clearing the Tines | 20 | | |
| Loading and Unloading the Tiller | 20 | | |

INTRODUCTION

Congratulations on your purchase of a Champion Power Equipment (CPE) product. CPE designs, builds, and supports all of our products to strict specifications and guidelines. With proper product knowledge, safe use, and regular maintenance, this product should bring years of satisfying service.

Every effort has been made to ensure the accuracy and completeness of the information in this manual at the time of publication, and we reserve the right to change, alter and/ or improve the product and this document at any time without prior notice.

Since CPE highly values how our products are designed, manufactured, operated and are serviced, and also highly value your safety and the safety of others, we would like you to take the time to review this product manual and other product materials thoroughly and be fully aware and knowledgeable of the assembly, operation, dangers and maintenance of the product before use. Fully familiarize yourself, and make sure others who plan on operating the product fully familiarize themselves too, with the proper safety and operation procedures before each use. Please always exercise common sense and always err on the side of caution when operating the product to ensure no accident, property damage, or injury occurs. We want you to continue to use and be satisfied with your CPE product for years to come.

When contacting CPE about parts and/or service, you will need to supply the complete model and serial numbers of your product. Transcribe the information found on your product's nameplate label to the table below

| |
|-----------------------------------|
| CPE TECHNICAL SUPPORT TEAM |
| 1-877-338-0999 |
| MODEL NUMBER |
| 100379 |
| SERIAL NUMBER |
| |
| DATE OF PURCHASE |
| |
| PURCHASE LOCATION |
| |

SAFETY DEFINITIONS

The purpose of safety symbols is to attract your attention to possible dangers. The safety symbols, and their explanations, deserve your careful attention and understanding. The safety warnings do not by themselves eliminate any danger. The instructions or warnings they give are not substitutes for proper accident prevention measures.

DANGER

DANGER indicates a hazardous situation which, if not avoided, will result in death or serious injury.

WARNING

WARNING indicates a hazardous situation which, if not avoided, could result in death or serious injury.

CAUTION

CAUTION indicates a hazardous situation which, if not avoided, could result in minor or moderate injury.

NOTICE

NOTICE is used to address practices not related to physical injury.

IMPORTANT SAFETY INSTRUCTIONS

WARNING

California Proposition 65: This product contains chemicals and produces exhaust known to the State of California to cause cancer, birth defects and other reproductive harm.

This machine meets voluntary safety standard B71.8 – 1996, which is sponsored by the Outdoor Power Equipment Institute, Inc., and is published by the American National Standards Institute.

Training

1. Carefully read this Operator's Manual and any other literature you may receive. Be thoroughly familiar with the controls and the proper use of the tiller and its engine. Know how to stop the unit and disengage the controls quickly.
2. Never allow children under age 16 to operate the tiller. Never allow adults to operate the tiller without proper instruction.
3. Keep the area of operation clear of all persons, particularly children and pets.
4. Keep in mind that the operator or user is responsible for accidents or hazards occurring to other people, their property, and themselves.

Preparation

1. Thoroughly inspect the area where the tiller is to be used and remove all foreign objects.
2. Be sure all tiller controls are released and both wheels are in the Wheel Drive position before starting the engine.
3. Do not operate the tiller without wearing adequate outer garments. Avoid loose garments or jewelry that could get caught in moving parts.
4. Do not operate the tiller when barefoot or wearing sandals, sneakers, or light footwear. Wear protective footwear that will improve footing on slippery surfaces.
5. Do not till near underground electric cables, telephone lines, pipes or hoses. If in doubt, contact your telephone or utility company.
6. Warning: Handle fuel with care; it is highly flammable and its vapors are explosive. Take the following precautions:
 - 6a. Store fuel in containers specifically designed for this purpose.
 - 6b. The gas cap shall never be removed or fuel added while the engine is running. Allow the engine to cool for several minutes before adding fuel.

- 6c. Keep matches, cigarettes, cigars, pipes, open flames and sparks away from the fuel tank and fuel container.
- 6d. Fill fuel tank outdoors with extreme care. Never fill fuel tank indoors. Use a funnel or spout to prevent spillage.
- 6e. Replace all fuel tank and container caps securely.
- 6f. If fuel is spilled, do not attempt to start the engine, but move the machine away from the area of spillage and avoid creating any source of ignition until fuel vapors have dissipated.
7. Never make adjustments when engine is running (unless recommended by manufacturer).

Operation

1. Do not put hands or feet near or under rotating parts.
2. Do Not attempt to till with tines in reverse
3. Exercise extreme caution when on or crossing gravel drives, walks, or roads. Stay alert for hidden hazards or traffic. Do not carry passengers.
4. After striking a foreign object, stop the engine, remove the wire from the spark plug and prevent it from touching the spark plug. Thoroughly inspect the machine for any damage and repair the damage before restarting and operating the machine
5. Exercise caution to avoid slipping or falling.
6. If the unit should start to vibrate abnormally, stop the engine, disconnect the spark plug wire and prevent it from touching the spark plug, and check immediately for the cause. Vibration is generally a warning of trouble.
7. Stop the engine, disconnect the spark plug wire and prevent it from touching the spark plug, whenever you leave the operating position, before unclogging the tines, or when making any repairs, adjustments or inspections.
8. Take all possible precautions when leaving the machine unattended. Stop the engine. Disconnect the spark plug wire and move it away from the spark plug.
9. Before cleaning, repairing, or inspecting, stop the engine and make certain all moving parts have stopped. Disconnect the spark plug wire and prevent it from touching the spark plug to prevent accidental starting.
10. Never use the tiller unless proper guards, plates, or other safety protective devices are in place.
11. Do not run the engine in an enclosed area. Engine exhaust contains carbon monoxide gas, a deadly poison that is odorless, colorless, and tasteless.
12. Keep children and pets away.

13. **Be aware that the tiller may unexpectedly bounce upward or jump forward if the tines should strike extremely hard packed soil, frozen ground, or buried obstacles like large stones, roots, or stumps.** If in doubt about the tilling conditions, always use the following operating precautions to assist you in maintaining control of the tiller:
 - 13a. Use shallower depth regulator settings, working gradually deeper with each pass.
 - 13b. Use slower engine speeds.
 - 13c. Clear the tilling area of all large stones, roots or other debris.
 - 13d. Avoid using downward pressure on the handlebars. If need be, use slight upward pressure to keep the tines from digging too deeply.
 - 13e. In an emergency, stop the tines and wheels by releasing whichever lever is engaged. Do not attempt to restrain the tiller.
14. Do not overload the tiller's capacity by attempting to till too deeply at too fast a rate.
15. Do not operate the tiller on a slope that is too steep for safety (greater than 15 degrees). When on slopes, slow down and make sure you have good footing. Never permit the tiller to freewheel down slopes.
16. Never allow bystanders near the unit.
17. Never operate the tiller without good visibility or light.
18. Never operate the tiller if you are tired; or under the influence of alcohol, drugs or medication.
19. Operators shall not tamper with the engine-governor settings on the machine; the governor controls the maximum safe operating speed to protect the engine and all moving parts from damage caused by overspeed. Authorized service shall be sought if a problem exists.
20. Do not touch engine parts which may be hot from operation. Let parts cool down sufficiently.
21. Please remember: You can always stop the tines by releasing control lever.
22. Start the engine carefully according to instructions and with feet well away from the tines.
23. Never pick up or carry a machine while the engine is running.

Maintenance and Storage

1. Check all nuts, bolts, and screws for proper tightness to be sure the equipment is in safe working condition.
2. Never store the tiller with fuel in the fuel tank inside a building where ignition sources are present, such as hot water and space heaters, furnaces, clothes dryers, stoves, electric motors, etc. Allow the engine to cool before storing the unit in any enclosure.
3. To reduce the chances of a fire, keep the engine free of grass, leaves, or excessive grease.
4. Store gasoline in a cool, well-ventilated area, safely away from any spark- or flame-producing equipment. Store gasoline in an approved container, safely away from the reach of children.
5. Never perform maintenance while the engine is running or the spark plug wire is connected, except when specifically instructed to do so.
6. If the fuel tank has to be drained, do this outdoors.

Fuel Safety

⚠ DANGER

GASOLINE AND GASOLINE VAPORS ARE HIGHLY FLAMMABLE AND EXPLOSIVE.

Fire or explosion can cause severe burns or death.

Gasoline and gasoline vapors:

- Gasoline is highly flammable and explosive.
- Gasoline can cause a fire or explosion if ignited.
- Gasoline is a liquid fuel but it's vapors can ignite.
- Gasoline is a skin irritant and needs to be cleaned up immediately if spilled on skin or clothes.
- Gasoline has a distinctive odor, this will help detect potential leaks quickly.
- In any petroleum gas fire, flames should not be extinguished unless by doing so the fuel supply valve can be turned OFF. This is because if a fire is extinguished and a supply of fuel is not turned OFF, then an explosion hazard could be created.
- Gasoline expands or contracts with ambient temperatures. Never fill the gasoline tank to full capacity, as gasoline needs room to expand if temperatures rise.

When adding or removing gasoline:

Turn the tiller off and let it cool for at least two minutes before removing the gasoline cap. Loosen the cap slowly to relieve pressure in the tank.

Only fill or drain gasoline outdoors in a well-ventilated area.

DO NOT pump gasoline directly into the tiller at the gas station. Use an approved container to transfer the fuel to the tiller.

DO NOT overfill the gasoline tank.

Always keep gasoline away from sparks, open flames, pilot lights, heat and other sources of ignition.

DO NOT light or smoke cigarettes.

When starting the tiller:

DO NOT attempt to start a damaged tiller.

Make certain that the gasoline cap, air filter, spark plug, fuel lines and exhaust system are properly in place.

Allow spilled gasoline to evaporate fully before attempting to start the engine.

Make certain that the tiller is resting firmly on level ground.

When operating the tiller:

DO NOT tip the tiller or allow fuel or oil to spill.

When transporting or servicing the tiller:

Make certain that the fuel valve is in the OFF position and the gasoline tank is empty.

Disconnect the spark plug wire.

When storing the tiller:

Store away from sparks, open flames, pilot lights, heat and other sources of ignition.



Do not store tiller or gasoline near furnaces, water heaters, or any other appliances that produce heat or have automatic ignitions.





⚠ WARNING

Never use a gasoline container, gasoline tank, or any other fuel item that is damaged or appears damaged.

Safety Symbols

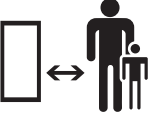



Some of the following symbols may be used on this product. Please study them and learn their meaning. Proper interpretation of these symbols will allow you to more safely operate the product.



| SYMBOL | MEANING |
|---|---|
|  | Read Operator's Manual. To reduce the risk of injury, user must read and understand operator's manual before using this product. |
|  | Eye and Ear Protection. Always wear safety goggles or safety glasses with side shields, and as necessary a full face-shield as well as full ear protection when operating this product. Always wear eye protection with side shields marked to comply with ANSI Z87.1. |
|  | Footwear. Always wear safety shoes or heavy boots when operating the machine. |
|  | Gloves. Always wear nonslip, heavy-duty protective gloves when operating this product. |
|  | Safety Alert. This machine was built to be operated according to the safe operation practices in this manual. As with any type of power equipment, carelessness or error on the part of the operator can result in serious injury. This machine is capable of amputating fingers, hands, toes and feet and throwing foreign objects. Failure to observe the safety instructions could result in serious injury or death. |
|  | Fire/Explosion. Fuel and its vapors are extremely flammable and explosive. Fire or explosion can cause severe burns or death. Operation of this equipment may create sparks that can start fires around dry vegetation. A spark arrestor may be required. The operator should contact local fire agencies for laws or regulations relating to fire prevention requirements. |
|  | Hot Surface. To reduce the risk of injury or damage, avoid contact with any hot surface. |
|  | Open Flame Alert. Fuel and its vapors are extremely flammable and explosive. Keep fuel away from smoking, open flames, sparks, pilot lights, heat, and other ignition sources. |

| SYMBOL | MEANING |
|---|---|
|  | <p>Toxic Fumes. The engine exhaust from this product contains chemicals known to cause cancer, birth defects and other reproductive harm.</p> <p>Risk of Asphyxiation. This engine emits carbon monoxide, an odorless, colorless poison gas. Breathing carbon monoxide can cause nausea, fainting or death. Use only in a well-ventilated area.</p> |
|  | <p>Clearance. Keep all objects including others at least 10 feet (3m) from this machine. Only one person should operate the tiller and load the logs.</p> |
|  | <p>Rotating Tines. Avoid injury from rotating tines. Keep hands away.</p> |
|  | <p>Rotating Tines. Avoid injury from rotating tines. Keep feet away.</p> |
|  | <p>Thrown Objects. This machine may pick up and throw objects which can cause serious personal injury.</p> |

Operation Symbols

Some of the following symbols may be used on this product. Please study them and learn their meaning. Proper interpretation of these symbols will allow you to more safely operate the product.

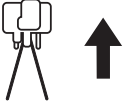
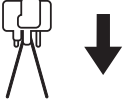
| SYMBOL | MEANING |
|---|--|
|  | Choke Lever CHOKE: left position RUN: right position |
|  | Fuel Valve CLOSED: left position OPEN: right position |
|  | Throttle Lever FAST: left position |
|  | Throttle Lever SLOW: right position |

| SYMBOL | MEANING |
|---|------------------------|
|  | Forward |
|  | Reverse |
|  | Engage Tines |
|  | Disengage Tines |

Quickstart Label Symbols

Some of the following symbols may be used on this product. Please study them and learn their meaning. Proper interpretation of these symbols will allow you to more safely operate the product.

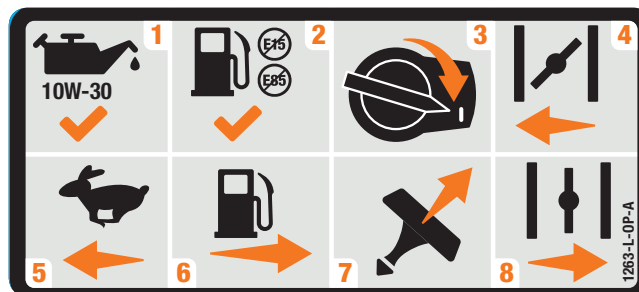

Starting the Engine

1. Check Oil Level. Recommended oil is 10W-30. The engine can be seriously damaged without oil. Always check the oil level before using. The machine must be resting firmly on level ground when checking.
2. Add gasoline with a minimum octane rating of 85 and an ethanol content of less than 10% by volume.
3. Turn the engine switch to “ON” position.
4. Move the choke lever to “CHOKE” position.
5. Move the throttle lever to “FAST” position.
6. Move the fuel valve to “OPEN” position.
7. Pull starter cord.
8. Move the choke lever to “RUN” position.

Safety Labels

These labels warn you of potential hazards that can cause serious injury. Read them carefully.

If a label comes off or becomes hard to read, contact Technical Support Team for possible replacement.

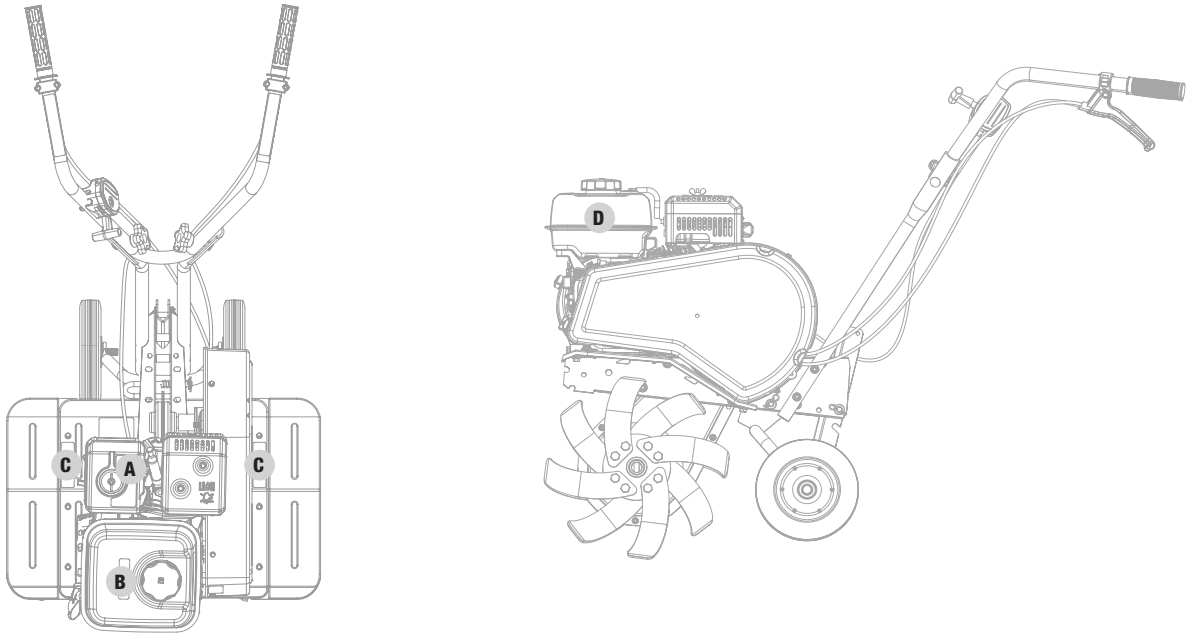

| | LABEL | DESCRIPTION |
|-----|-------|-----------------------------------|
| A | | Hot Surface |
| B | | Fuel |
| C | | Safety Icons |
| N/A | | Combustion (not shown in diagram) |
| D | | Safety Icons |

CONTROLS AND FEATURES

Read this operator's manual before operating your tiller. Familiarize yourself with the location and function of the controls and features. Save this manual for future reference.

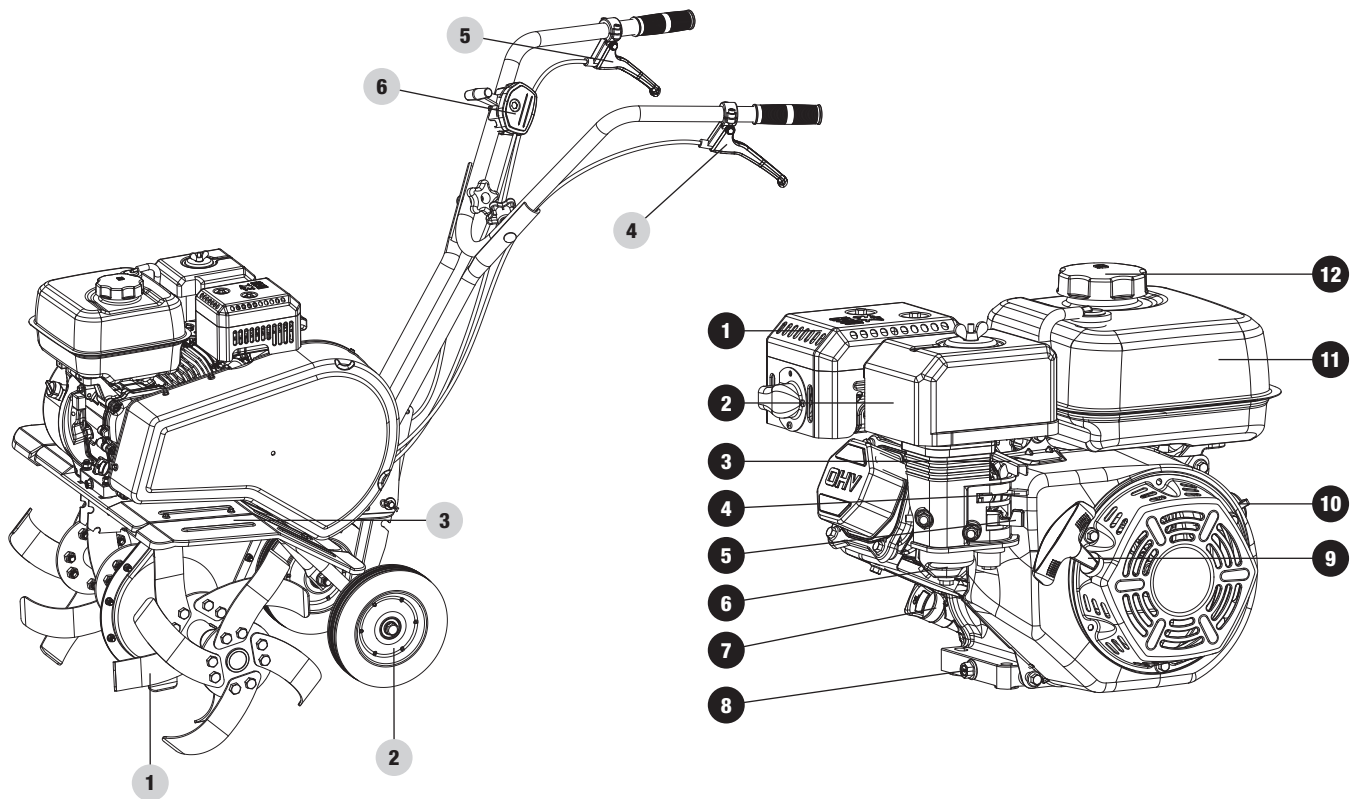

Tiller

1. Tines
2. Transport Wheels
3. Tine Shield
4. Reverse Lever
5. Forward Lever
6. Speed Control

Engine

1. **Muffler**
2. **Air Filter** – Protects the engine by filtering dust and debris from the intake air.
3. **Throttle**
4. **Choke** – Used to start the engine.
5. **Fuel Valve** – Used to turn fuel supply on and off to engine.
6. **Carburetor**
7. **Oil Fill Cap/Dipstick** – Used to check and fill oil level.
8. **Oil Drain Bolt** – Used to drain the oil.
9. **Recoil Starter** – Used to manually start the engine.
10. **Engine On/Off Switch**
11. **Gasoline Tank** – 0.9 gal. (3.2 L)
12. **Gasoline Tank Cap**

Parts Included

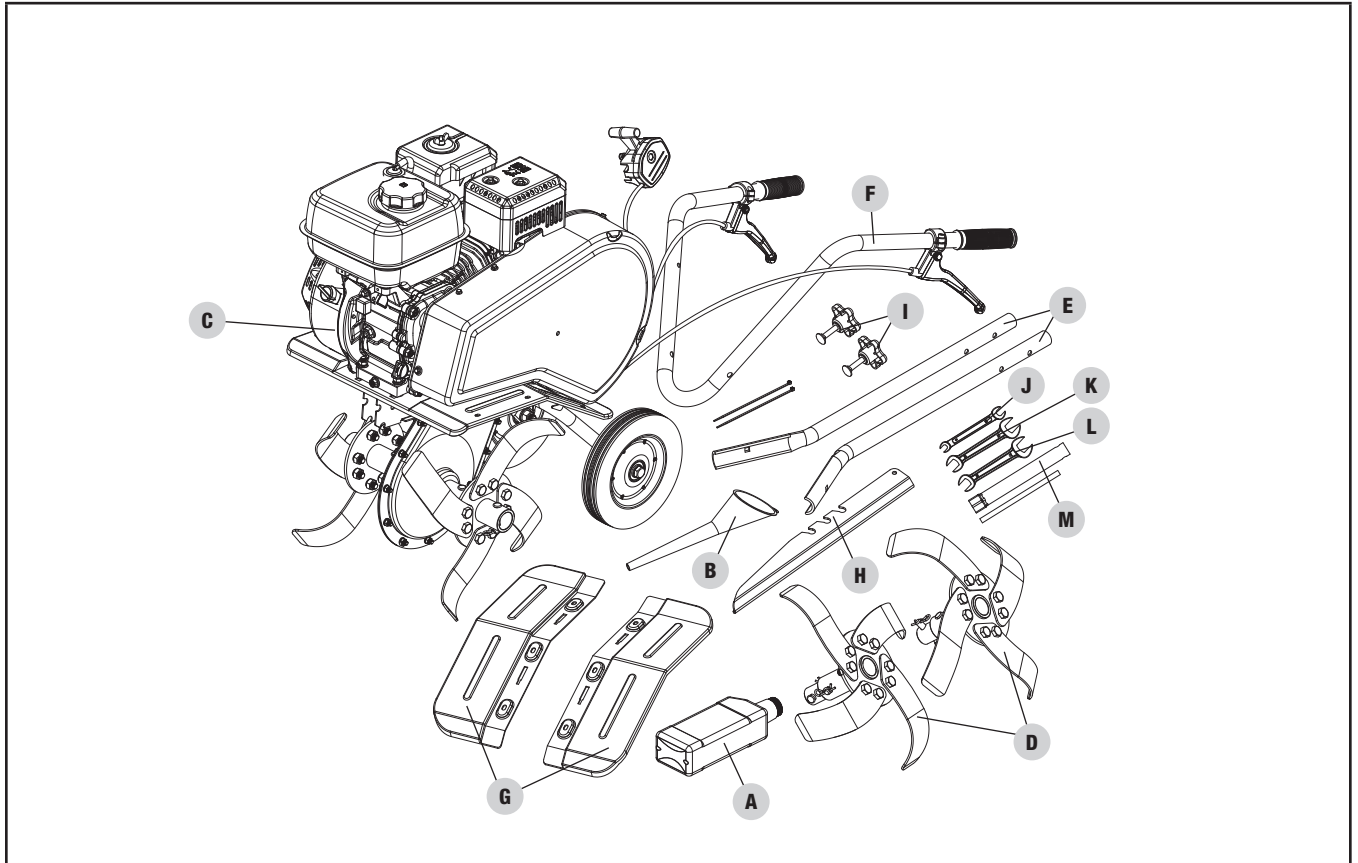

Accessories

- Engine Oil (0.6 qt.).....A
- Oil Funnel.....B

Assembly Parts

- Tiller main body with inner tinesC
- Outer tinesD
- Lower handles.....E
- Upper handle.....F
- Guard extensions.....G
- Depth RegulatorH
- Knobs.....I

Hardware

- Bolts (not shown)
- Nuts..... (not shown)
- Washers..... (not shown)

Tools Included

- 8–10 Wrench..... J
- 13–16 Wrench.....K
- 13–17 Wrench.....L
- Spark Plug Wrench.....M

Tools Not Included

- Needle Nose Pliers (for cotter pins)

ASSEMBLY

Your tiller requires some assembly. This unit ships from our factory without oil. It must be properly serviced with fuel and oil before operation.

If you have any questions regarding the assembly of your tiller, call our Technical Support Team at 1-877-338-0999. Please have your serial number and model number available.

Unpacking

1. Set the shipping carton on a solid, flat surface.
2. Remove everything from the carton except the tiller.
3. Carefully cut each corner of the box from top to bottom.
4. Fold each side flat on the ground to provide a surface area to work with the tiller.

Install Lower Handle

1. Mount lower handles onto tiller body using the (2) M8 bolts, (4) flat washers, (2) lock washers, and (2) M8 lock nuts.

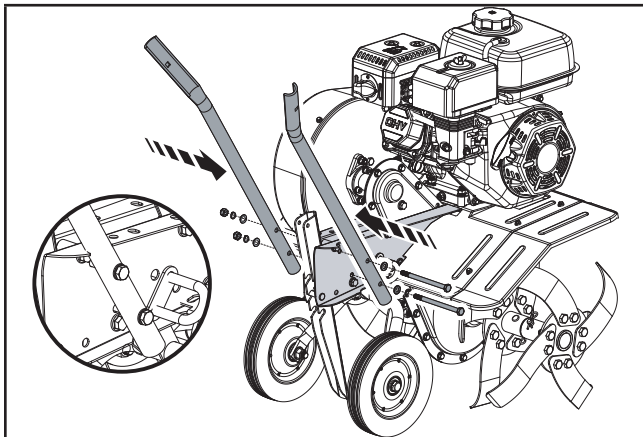

Install Upper Handle

1. Mount upper handle using (2) M8 round head bolts, (2) flat washers, and (2) knobs.

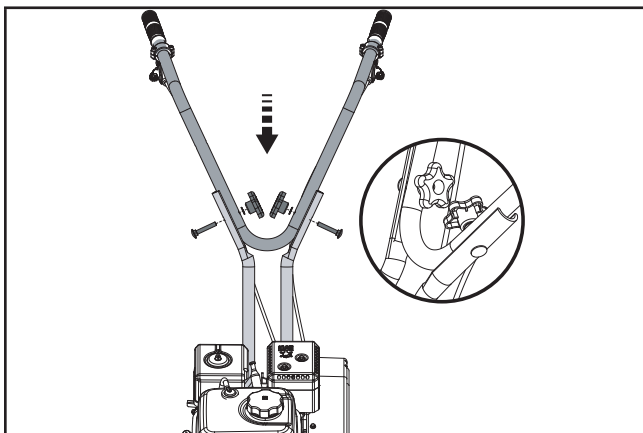

Install the Guard Extension

1. Mount the side guard extensions as shown - slide guard extension in and lock in place for each side.

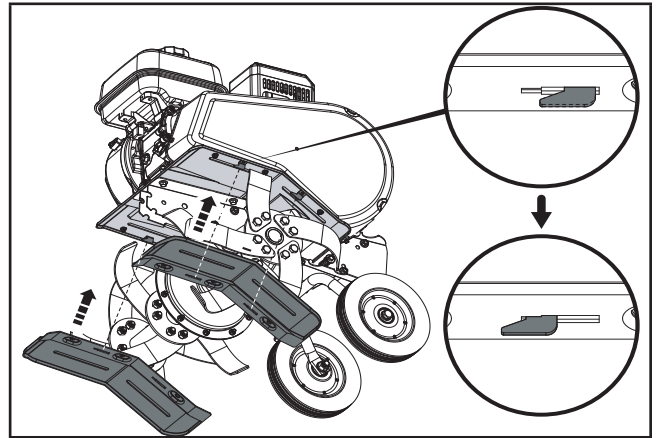

2. Attach using the (6) M5 bolts and (6) flanged lock nuts. Three sets for each side.

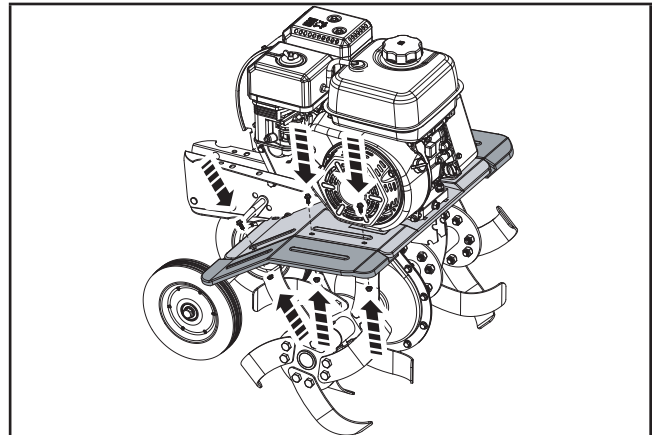

Install the Outer Tines

1. Remove cotter bolt and pin on each outer tine as shown:

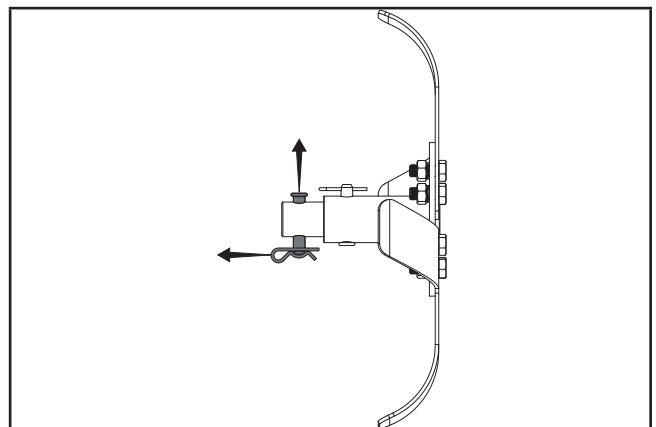

2. Mount the outer tines using the removed cotter bolts and pins:

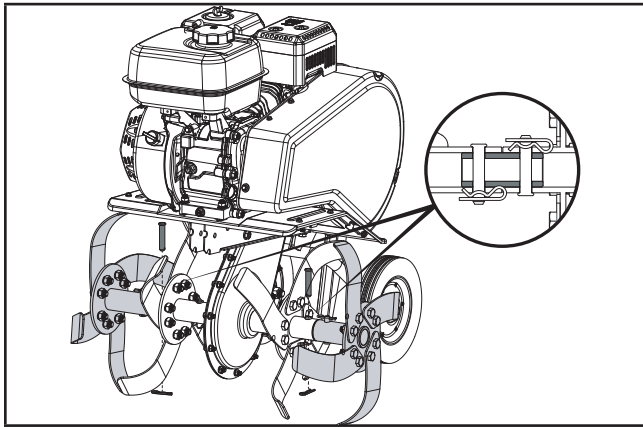

| Recommended Oil Type / Tipo de aceite recomendado / Type d'huile recommandé | | | | | | | | | |
|---|---|-------|------|--------|--------|------|------|------|--|
| | | | | 10W-30 | | | | | |
| | 5W-30 | | | | 10W-40 | | | | |
| | 5W-30 Synthetic / Sintético / Synthétique | | | | | | | | |
| °F | -20 | 0 | 20 | 40 | 60 | 80 | 100 | 120 | |
| °C | -28.9 | -17.8 | -6.7 | 4.4 | 15.6 | 26.7 | 37.8 | 48.9 | |
| Ambient temperature / Temperatura ambiente / Température ambiante | | | | | | | | | |

Install Speed Control

1. Mount speed control assembly to upper handle bar using (1) M6 bolt, (1) flat washer and (1) M6 lock nut.

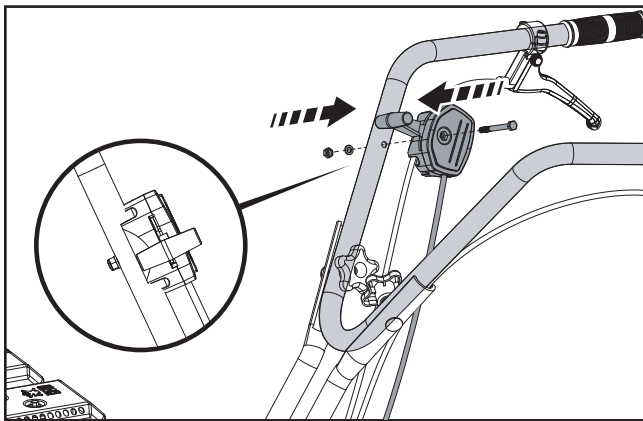

Add Engine Oil

1. Place tiller on a flat, level surface.
2. Put the wheels in the WHEEL DRIVE position.
3. Remove oil fill cap/dipstick to add engine oil.
4. Using a funnel, add up to 0.6 qt. (0.6 L) of oil and replace oil fill cap/dipstick. DO NOT OVERFILL.
5. Check engine oil level and add as needed.

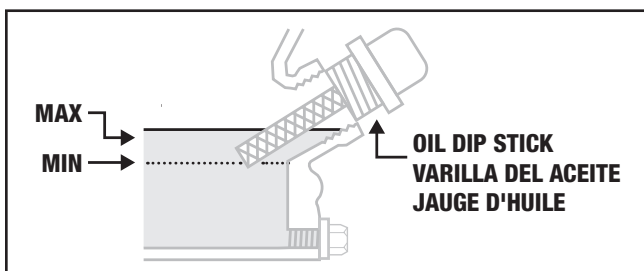

Add Fuel

1. Use clean, fresh, regular unleaded gasoline with a minimum octane rating of 85 and an ethanol content of 10% or less by volume. **E10 E85 E85**
2. DO NOT mix oil with gasoline.
3. Remove the gasoline cap.
4. Slowly add gasoline to the tank. DO NOT OVERFILL.

Gasoline can expand after filling. A minimum of ¼ in. (6.4 mm) of space left in the tank is required for gasoline expansion although more than ¼ in. (6.4 mm) is recommended. Gasoline can be forced out of the tank as a result of expansion if overfilled and can affect the stable running condition of the tiller.

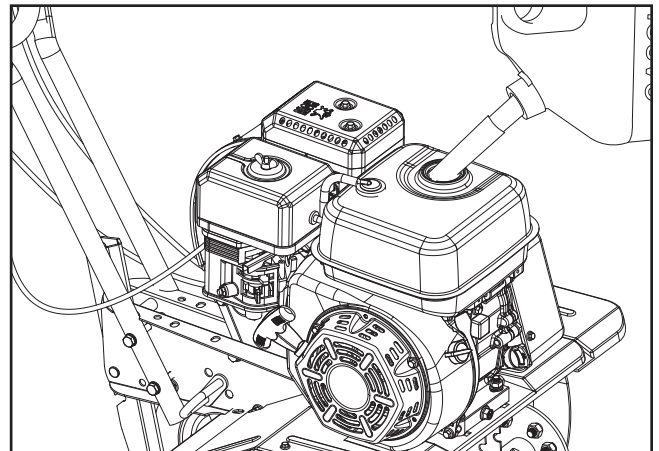

⚠ CAUTION

Use regular unleaded gasoline with a minimum octane rating of 85 and an ethanol content of 10% or less by volume.

DO NOT mix oil and gasoline.

Fill tank to approximately ¼ in. (6.4 mm) below the top of the tank to allow for gasoline expansion.

DO NOT pump gasoline directly into the tiller at the pump. Use an approved container to transfer the gasoline to the tiller.

DO NOT fill tank indoors.

DO NOT fill tank when the engine is running or hot.

DO NOT overfill the tank.

DO NOT light cigarettes or smoke when filling the tank.

⚠ WARNING

Pouring gasoline too fast through the fuel screen may result in blow back of gasoline at the operator while filling.

🗨 NOTICE

Our engines work well with 10% or less ethanol blend gasoline. When using ethanol-gasoline blends there are some issues worth noting:

- Ethanol-gasoline blends can absorb more water than gasoline alone.
- These blends can eventually separate, leaving water or a watery goo in the tank, fuel valve and carburetor.
- With gravity-fed supplies, the compromised gasoline can be drawn into the carburetor and cause damage to the engine and/or potential hazards.
- There are only a few suppliers of fuel stabilizer that are formulated to work with ethanol-gasoline blends.
- Any damages or hazards caused by using improper gasoline, improperly stored gasoline, and/or improperly formulated stabilizers, are not covered by manufacturer's warranty.

It is advisable to always shut off the gasoline supply, run the engine to starvation and drain the tank when the equipment is not in use for more than 30 days.

Forward Tine Control Lever

The Forward Tine rotation lever engages the tines in a forward direction pulling the tiller forward. The operator will need to

hold the tiller from moving forward to allow the tines to engage the soil and dig downward.

To operate the Forward Tine Control Lever:

1. Store transport wheels by flipping the upward and locking using the wheel adjustment pin.
2. Squeeze the lever upward until it engages the handle
3. Release lever to disengage (stop) tines

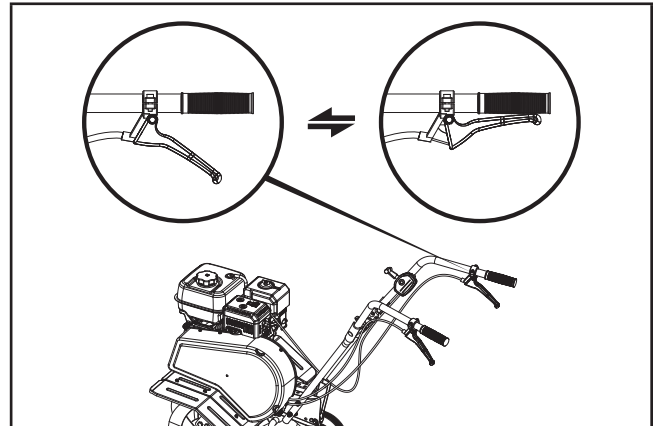
**Reverse Tine Control Lever**

The reverse tine control lever reverses the rotation of the tines so the tiller can be removed from tight spaces, obstructions or entanglements.

To operate the Reverse Tine Control Lever:

1. Pull the reverse tine control upward toward the handle and slowly back the tiller out of the undesired space
2. Ensure all tiller tine motion has stopped before re-engaging tines.
3. Release the lever to disengage (stop) the wheels and tines (the engine will continue to run).

⚠ WARNING

DO NOT till in reverse.

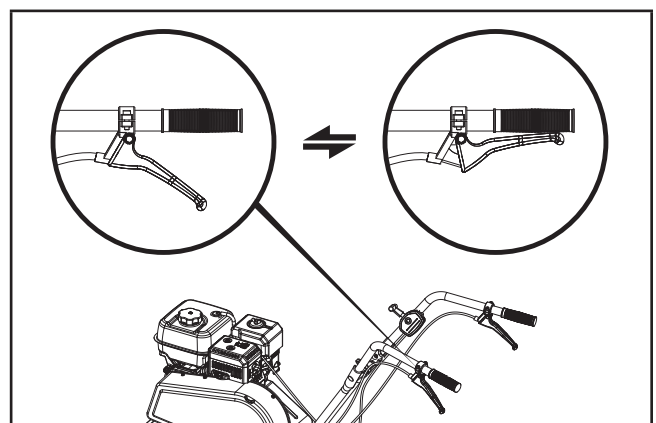

Depth Regulator Lever Adjustment

This regulator lever controls the tilling depth of the tines. Remove pin and clip and slide regulator lever up or down as required. Reassemble pin and clip.

The “travel position” (highest hole) raises the tines approximately 1-1/2 in. (4 cm) off the ground, allowing the tiller to be moved without the tines contacting the ground. This setting should also be used when starting the engine.

Moving the regulator lever upward will increase the tilling depth. The lowest notch allows a tilling depth of approximately 6 in. (15 cm), depending on soil conditions. For best results, always begin tilling at a very shallow depth setting and gradually increase the tilling depth.

⚠ WARNING

Do not attempt to till too deeply too quickly.

Gradually work down to deeper tilling depths.

Place the Depth Regulator Lever in the “travel” position before starting the engine. This position prevents the tines from touching the ground until you are ready to begin tilling.

Failure to follow this warning could result in personal injury or property damage.

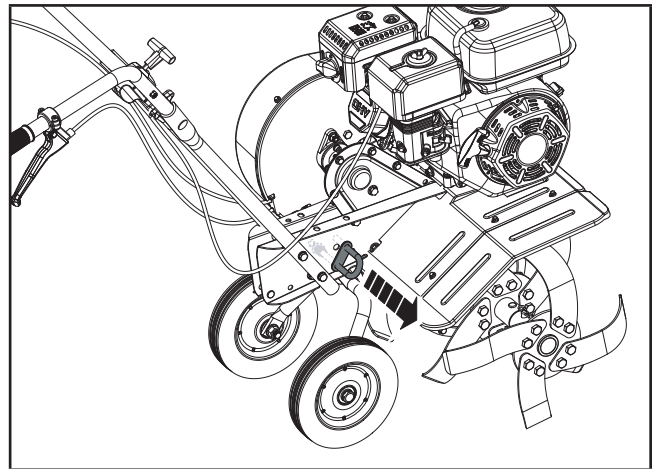
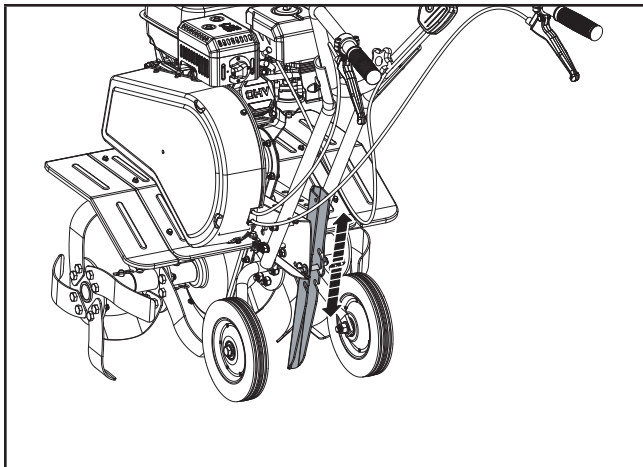

2. Swing the wheel assembly upward for tilling depth adjustment or downward for transport mode. Insert the spring loaded locking pin to lock wheel height at desired level.

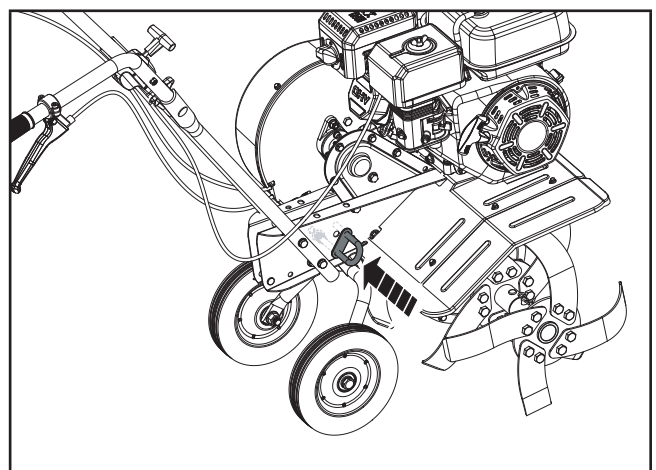
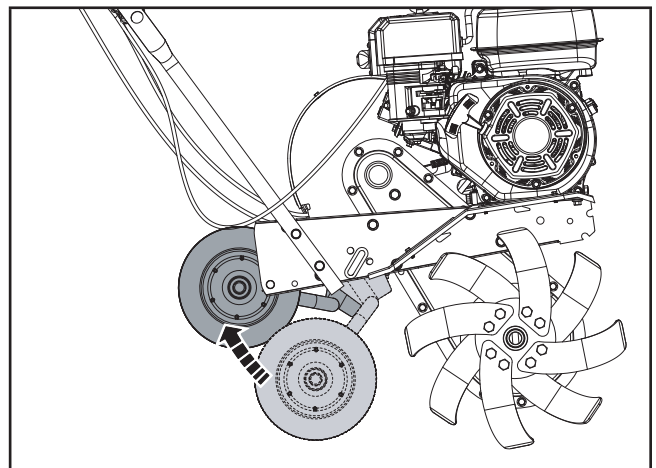

Transport Wheel Height Adjustment

The quick store transport wheels allow the operator to easily move the tiller to and from the garden and stow in moments when its time to start tilling.

1. Pull spring loaded locking pin away from the tiller body.

OPERATION

⚠ WARNING

Before operating your machine, carefully read and understand all safety, controls and operating instructions in this Operator's Manual.

Failure to follow these instructions can result in serious personal injury

Introduction

Read this section before you start the engine. Then, take the time to familiarize yourself with the basic operation of the tiller before using it in the garden. Find an open, level area and practice using the tiller controls without the tines engaging the soil (put tines in "travel" setting). Only after you've become completely familiar with the tiller should you begin using it in the garden.

Starting the Engine

To help prevent serious personal injury or damage to equipment

⚠ WARNING

Do not attempt to engage the tines or wheels until you have read all of the operating instructions

⚠ WARNING

Before starting engine, put both wheels in the WHEEL DRIVE position. Never have wheels in FREEWHEEL position when engine is running. When the wheels are in FREEWHEEL, they do not hold back the tiller and the tines could propel the tiller rapidly forward or backward.

⚠ WARNING

Never run engine indoors or in enclosed, poorly ventilated areas. Engine exhaust contains carbon monoxide, an odorless and deadly gas.

⚠ WARNING

Keep away from rotating tines. Rotating tines will cause injury.

1. Make certain the tiller is on a flat, level surface.
2. Release all controls on the tiller.
3. Flip engine switch to the "ON" position.

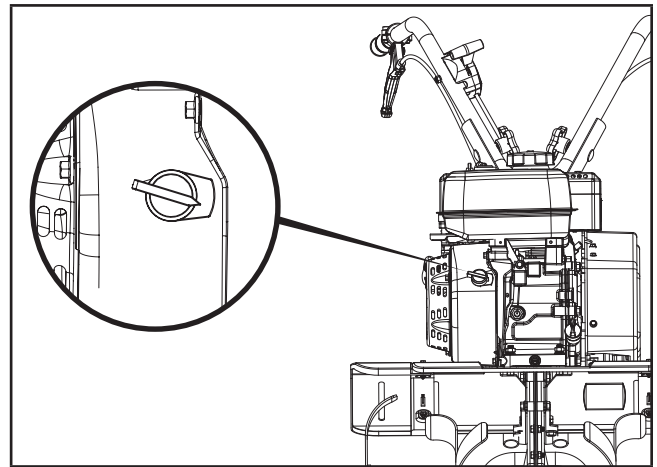

4. Move the choke lever to the "Choke" position.
5. Move the throttle lever to the "Fast" position.
6. Move the fuel valve to the "ON" position.

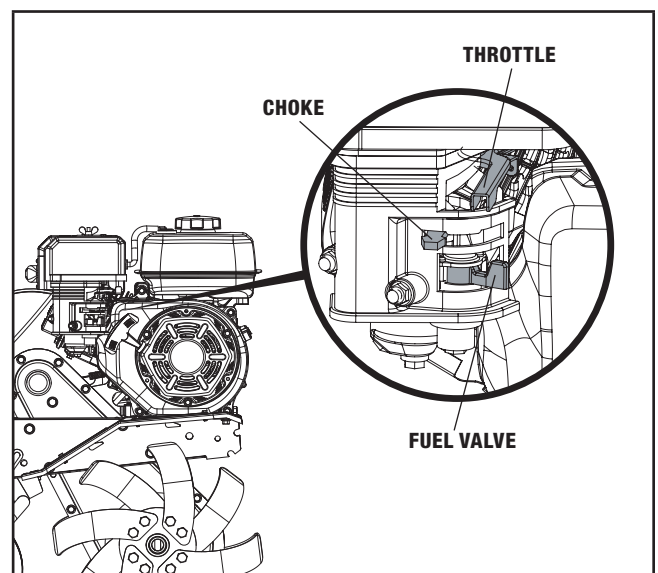

7. Pull the starter cord slowly until resistance is felt and then pull rapidly.

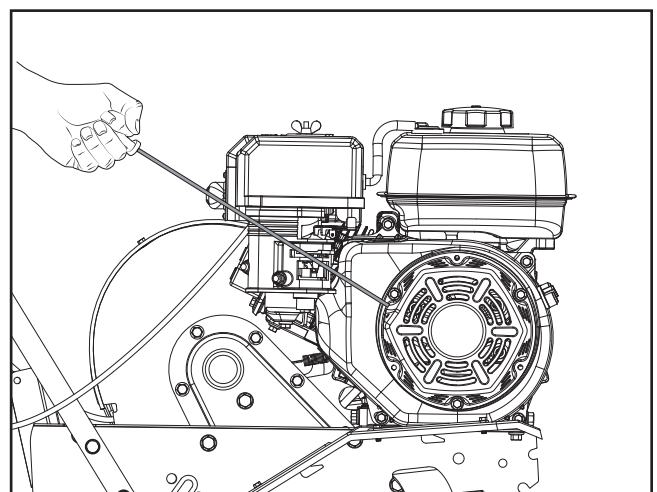

8. As engine warms up, move the choke lever to the "Run" position.

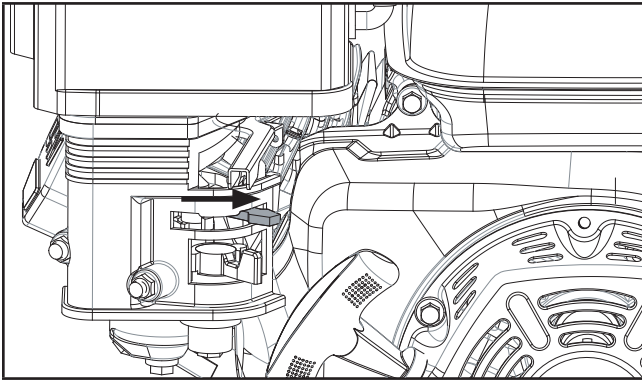

NOTICE

If the engine starts but does not run, make certain that the tiller is on a flat, level surface. The engine is equipped with a low oil sensor that will prevent the engine from running when the oil level falls below a critical threshold.

Stopping the Engine and the Tiller

In an emergency, turn the engine switch to the “OFF” position.

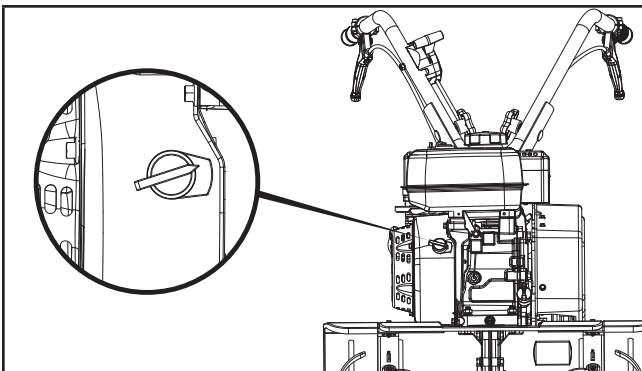

Under normal operation:

1. To stop the tines, release all control levers.
2. Turn the fuel valve to the “OFF” position.

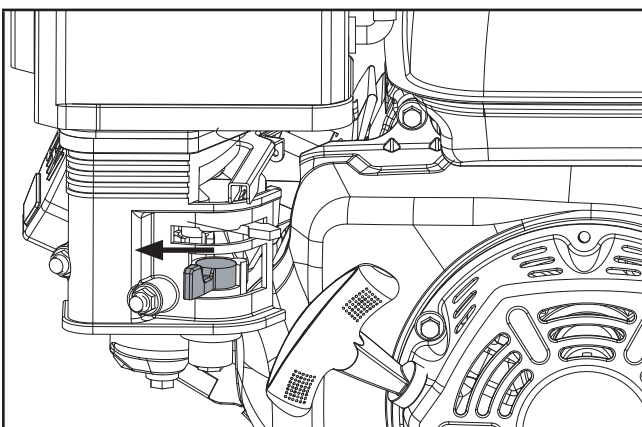

3. Let the engine run until fuel starvation has stopped the engine. This usually takes a few minutes.

4. Turn the engine switch to the “OFF” position.

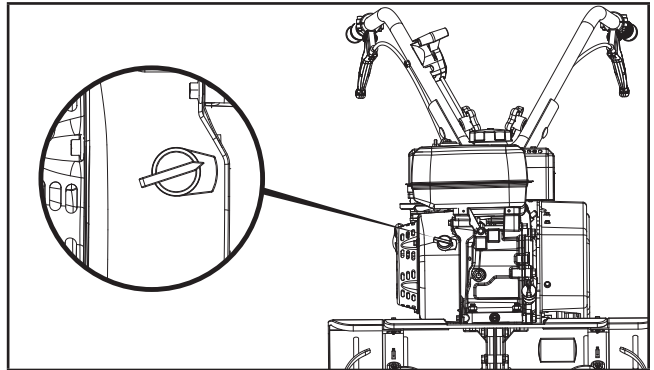

Operation at High Altitude

The density of air at high altitude is lower than at sea level. Engine power is reduced as the air mass and air-fuel ratio decrease. Engine power and generator output will be reduced approximately 3½% for every 1000 ft. of elevation above sea level. This is a natural trend and cannot be changed by adjusting the engine. At high altitudes increased exhaust emissions can also result due to the increased enrichment of the air fuel ratio. Other high altitude issues can include hard starting, increased fuel consumption and spark plug fouling.

To alleviate high altitude issues other than the natural power loss, CPE can provide a high altitude carburetor main jet. The alternative main jet and installation instructions can be obtained by contacting our Technical Support Team. Installation instructions are also available in the Technical Bulletin area of the CPE website.

The part number and recommended minimum altitude for the application of the high altitude carburetor main jet is listed in the table below.

In order to select the correct high altitude main jet it is necessary to identify the carburetor model. For this purpose, a code is stamped on the side of the carburetor. Select the correct high altitude jet part number corresponding to the carburetor code found on your particular carburetor.

| Carb. Code | High Alt. Jet Part Number | Min. Altitude |
|------------|---------------------------|-------------------|
| Z530610 | 16161-Z010310-0000 | 3000 ft. (914 m) |
| | 16161-Z050210-0000 | 6000 ft. (1829 m) |

⚠ WARNING

Operation using the alternative main jet at elevations lower than the recommended minimum altitude can damage the engine. For operation at lower elevations, the originally supplied standard main jet must be used. Operating the engine with the wrong engine configuration at a given altitude may increase its emissions and decrease fuel efficiency and performance.

TILLING TIPS AND TECHNIQUES**Tilling Depths****⚠ WARNING**

Before tilling, contact your telephone or utilities company and inquire if underground equipment or lines are used on your property. Do not till near buried electric cables, telephone lines, pipes or hoses.

Avoid trying to dig too deeply too quickly, especially when busting sod or when tilling soil that hasn't been tilled for some time. Use shallow depth regulator settings (only an inch or two deep) for the first passes through the soil. With each succeeding pass, dig another inch or two deeper. (Watering the area a few days prior to tilling will make the tilling easier, as will letting the newly worked soil set for a day or two before making a final, deep tilling pass.

When cultivating (breaking up surface soil around plants to destroy weeds), adjust the tines to dig only 1 in. to 2 in. (2.5 to 5 cm) deep. Using shallow tilling depths helps prevent injury to plants whose roots often grow close to the surface. If needed, lift up on the handlebars slightly to prevent the tines from digging too deeply. (Cultivating on a regular basis not only eliminates weeds, it also loosens and aerates the soil for better moisture absorption and faster plant growth.)

Choosing Correct Tine Speed

With experience, you will find the "just right" tilling depth and tilling speed combination that is best for your garden.

Set the engine throttle lever at a speed to give the engine adequate power and yet allow it to operate at the slowest possible speed ... at least until you have achieved the maximum tilling depth you desire. Faster engine speeds may be desirable when making final passes through the seedbed or when cultivating. Selection of the correct engine speed, in relation to the tilling depth, will ensure a sufficient power level to do the job without causing the engine to labor.

Avoid Tilling Soggy, Wet Soil

Tilling wet soil often results in large, hard clumps of soil that can interfere with planting. If time permits, wait a day or two after heavy rains to allow the soil to dry before tilling. Test soil by squeezing it into a ball. If it compresses too easily, it is too wet to till.

Preparing Seedbeds

When preparing a seedbed, go over the same path twice in the first row, then overlap one-half the tiller width on the rest of the passes. When finished in one direction, make a second pass at a right angle. Overlap each pass for best results (in very hard ground, it may take three or four passes to thoroughly pulverize the soil.)

If the garden size will not permit lengthwise and then crosswise tilling, then overlap the first passes by one-half a tiller width, followed by successive passes at one quarter width.

Cultivating

With planning, you can allow enough room between rows to cultivate. Leave room for the hood width, plus enough extra room for future plant growth.

Tilling on Slopes

Read the following recommendations before tilling on slopes:

If you must garden on a moderate slope, please follow two very important guidelines:

1. Till only on moderate slopes, never on steep ground where footing is difficult.
2. We recommend tilling up and down slopes rather than terracing. Tilling vertically on a slope allows maximum planting area and also leaves room for cultivating.

IMPORTANT: When tilling on slopes, be sure the correct oil level is maintained in the engine (check every one-half hour of operation). The incline of the slope will cause the oil to slant away from its normal level and this can starve engine parts of required lubrication. Keep the motor oil level at the full point at all times!

⚠ WARNING

Do not operate tiller on a slope too steep for safe operation. Till slowly and be sure you have good footing. Never permit tiller to freewheel down slopes. Failure to follow this warning could result in personal injury.

Tilling Up and Down Slopes (Vertical Tilling)

To keep soil erosion to a minimum, be sure to add enough organic matter to the soil so that it has good moisture-holding texture and try to avoid leaving footprints or wheel marks.

When tilling vertically, try to make the first pass uphill as the tiller digs more deeply going uphill than it does downhill. In soft soil or weeds, you may have to lift the handlebars slightly while going uphill. When going downhill, overlap the first pass by about one-half the width of the tiller.

Tilling Across Slopes Without Using Terraces (Horizontal Tilling)

If vertical or terracing gardening aren't practical for you, then you can till laterally across a slope. We don't recommend this method as it can create unsure footing and invites soil erosion.

As in terrace gardening, start at the top of the slope and overlap the first pass by half the width of the tiller. For added stability of the tiller, always keep the uphill wheel in the soft, newly tilled soil.

Terrace Gardening

- When a slope is too steep or too short for vertical tilling, it may be necessary to till across the slope and create terraced rows. Terraces are rows that are cut into the side of a slope, creating a narrow, but flat area on which to plant.
- On a long slope, you can make several terraces, one below the other.
- Terraces should be only 2-to-3 ft. (60-90 cm) wide. Digging too far into the side of the slope will expose poor subsoil that is unproductive for plants.
- To create a terrace, start at the top of the slope and work down. Go back and forth across the first row.
- Each succeeding lower terrace is started by walking below the terrace you're preparing. For added stability of the tiller, always keep the uphill wheel in the soft, newly tilled soil. Do not till the last 12 in. (30 cm) or more of the downhill outside edge of each terrace. This untilled strip helps prevent the terraces from breaking apart and washing downhill. It also provides a walking path between rows.

Clearing the Tines

The tines have a self-clearing action which eliminates most tangling of debris in the tines. However, occasionally dry grass, stringy stalks or tough vines may become tangled. Follow these procedures to help avoid tangling and to clean the tines, if necessary.

- To reduce tangling, set the depth regulator deep enough to get maximum "chopping" action as the tines chop the material against the ground. Also, try to till under crop residues or cover crops while they are green, moist and tender.
- While power composting, try swaying the handlebars from side to side about 6 in. to 12 in. (15 to 30 cm). This "fishtailing" action often clears the tines of debris.

- If tangling occurs, lift the tines out of the soil and run the tiller in reverse (if unit is equipped with powered reverse) for a few feet. This reversing action should unwind a good deal of debris.
- It may be necessary to remove the debris by hand (a pocket knife will help you to cut away the material). Be sure to stop the engine and disconnect the spark plug wire before clearing the tines by hand.

⚠ WARNING

Before clearing the tines by hand, stop the engine, allow all moving parts to stop and disconnect the spark plug wire.

Remove the ignition key on electric start models.

Failure to follow this warning could result in personal injury.

Loading and Unloading the Tiller

⚠ WARNING

Loading and unloading the tiller into a vehicle is potentially hazardous and we don't recommend doing so unless absolutely necessary, as this could result in personal injury or property damage. However, if you must load or unload the tiller, follow the guidelines given next.

- Before loading or unloading, stop the engine, wait for all parts to stop moving, disconnect the spark plug wire and let the engine and muffler cool.
- The tiller is too heavy and bulky to lift safely by one person. Two or more people should share the load.
- Use sturdy ramps and manually (engine shut off) roll the tiller into and out of the vehicle. Two or more people are needed to do this.
- The ramps must be strong enough to support the combined weight of the tiller and any handlers. The ramps should provide good traction to prevent slipping; they should have side rails to guide the tiller along the ramps; and they should have a locking device to secure them to the vehicle.
- The handlers should wear sturdy footwear that will help to prevent slipping.
- Position the loading vehicle so that the ramp angle is as flat as possible (the less incline to the ramp, the better). Turn the vehicle's engine off and apply its parking brake.
- When going up ramps, stand in the normal operating position and push the tiller ahead of you. Have a person at each side to turn the wheels.

- When going down ramps, walk backward with the tiller following you. Keep alert for any obstacles behind you. Position a person at each wheel to control the speed of the tiller. Never go down ramps tiller-first, as the tiller could tip forward.
- Place wooden blocks on the downhill side of the wheels if you need to stop the tiller from rolling down the ramp. Also, use the blocks to temporarily keep the tiller in place on the ramps (if necessary), and to chock the wheels in place after the tiller is in the vehicle.
- After loading the tiller, prevent it from rolling by engaging the wheels in the WHEEL DRIVE position. Chock the wheels with blocks and securely tie the tiller down.

MAINTENANCE

WARNING

Before inspecting, cleaning or servicing the machine, shut off engine, wait for all moving parts to come to a complete stop, disconnect spark plug wire and move wire away from spark plug. Remove ignition key on electric start models.

Failure to follow these instructions can result in serious personal injury or property damage.

BEFORE EACH USE

- Check motor oil level
- Clean engine
- Check air filter element
- Check reduction gear oil

FIRST 2 HOURS OF BREAK-IN OPERATION

- Check drive belt tension
- Check nuts and bolts
- Change engine oil

EVERY 5 OPERATING HOURS

- Check motor oil level

EVERY 10 OPERATING HOURS

- Check drive belt tension
- Check nuts and bolts
- Change engine oil
- Lubricate tiller

EVERY FIRST MONTH OR FIRST 20 HOURS

- Change engine oil
- Replace reduction gear oil
- Clean air filter element

EVERY 30 OPERATING HOURS

- Check gear oil level in transmission
- Check tines for wear
- Check air pressure in tires (if unit has pneumatic tires)

EVERY 3 MONTHS OR EVERY 50 HOURS OF OPERATION

- Change engine oil
- Replace reduction gear oil
- Replace air filter element
- Clean spark arrester

EVERY YEAR OR EVERY 100 HOURS OF OPERATION

- Clean deposit cup
- Check/adjust spark arrester*
- Check/adjust idling
- Check/adjust valve clearance**
- Clean fuel tank and fuel filter**

EVERY TWO YEARS

- Check fuel line

EVERY 125 HOURS

- Clean up carbon from cylinder head piston**

NOTICE

- Change the engine oil after the first 2 hours of break-in operation.
- Change the engine oil more frequently in dusty conditions.

** These items should be replaced if replacement needed.

*** These items should be maintained and repaired by our authorized dealer, unless the owner has appropriate tools and is proficient with mechanical maintenance.

Tiller Lubrication

After every 10 operating hours, oil or grease the lubrication points as described below.

Use clean lubricating oil (#30 weight engine oil is suitable) and clean general purpose grease (grease containing a metal lubricant is preferred, if available).

- Remove the wheels, clean the wheel shaft and apply a thin coating of grease to the wheel shaft.
- Grease the back, front and sides of the depth regulator lever.
- Remove the tines and clean the tine shaft. Use a file or sandpaper to gently remove any rust, burrs or rough spots (especially around holes in shaft). Apply grease to ends of shaft before installing tines.
- Oil the threads on the handlebar height adjustment screws and the handlebar attaching screws.

Check for Oil Leaks

Before each use, check the tiller for signs of an oil leak — usually a dirty, oily accumulation either on the unit or on the floor.

A little seepage around a cover or an oil seal is usually not a cause for alarm. However, if the oil drips overnight, then immediate attention is needed. Ignoring an oil leak can result in severe transmission damage!

If a cover is leaking, check for loose screws. If the screws are tight, a new gasket or oil seal may be required.

If the leak is from around a shaft and oil seal, the oil seal probably needs to be replaced. See your authorized dealer or contact the factory for service or advice.

IMPORTANT: Never operate the tiller if the transmission is low on oil. Check the oil level after every 30 hours of operation and whenever there is any oil leakage.

Check Hardware

Check for loose or missing hardware after every 10 operating hours and tighten or replace (as needed) before reusing tiller.

Be sure to check the screws underneath the tiller hood that secure the transmission cover and the Depth Regulator Lever to the transmission.

Tines

The tines will wear with use and should be inspected at the beginning of each tilling season and after every 30 operating hours. The tines can be replaced either individually or as a complete set. Refer to the parts list for tine identification and part numbers.

A. Tine Inspection:

With use, the tines will become shorter, narrower and pointed. Badly worn tines will result in a loss of tilling depth, and

reduced effectiveness when chopping up and turning under organic matter.

B. Removing/Installing a Single Tine:

1. With the engine shut off and the spark plug wire disconnected, remove the M10×25 bolt, lock washer, flat washer and M10 nut that attach a single tine to a tine holder. If needed, use penetrating oil on the nuts.
2. When installing a single tine, be sure to position it so that its cutting edge (sharp) will enter the soil first as the tiller moves forward. Hand tighten completely.

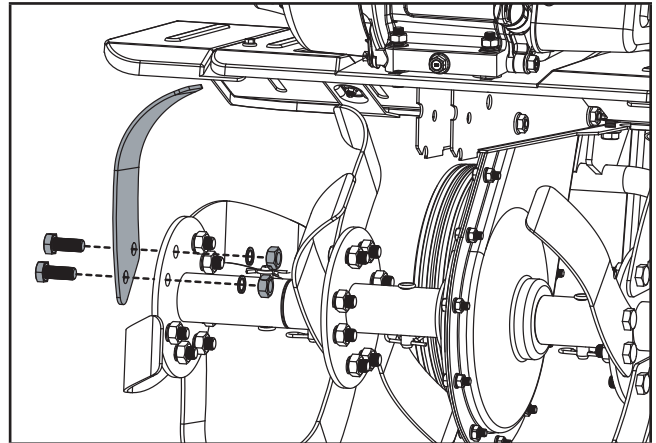

C. Removing/Installing a Tine Assembly:

1. A tine assembly consists of eight tines mounted on a tine holder.
2. If removing both tine assemblies, mark them “left” and “right” before removal. Remove (2) pins and (2) cotter pins that secure the tine assembly to the tine shaft. If necessary, use a rubber mallet to tap the tine assembly outward off the shaft.
3. Before reinstalling the tine assembly, inspect the tine shaft for rust, rough spots or burrs. Lightly file or sand, as needed. Apply a thin coat of grease to the shaft.
4. Install each tine assembly so that the cutting (sharp) edge of the tines will enter the soil first when the tiller moves forward.
5. Bend cotter pins once inserted to prevent the pins from coming out.

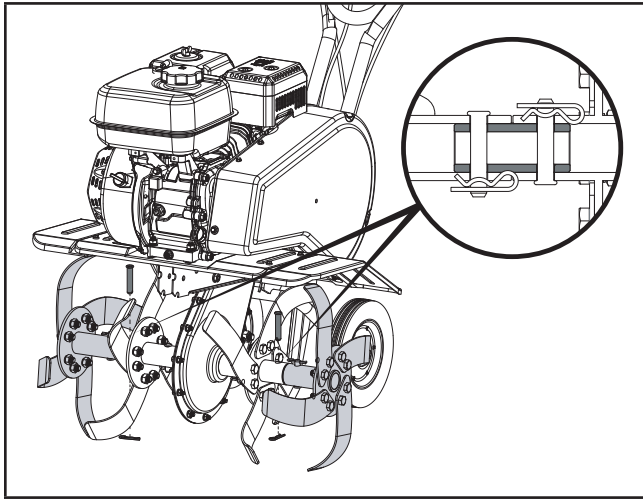

Checking and Adjusting the Tine Drive Belt Tension

It is important to maintain correct tension on the forward and reverse tine drive belt drive. A loose belt will cause the tines to slow down — or stop completely — even though the engine is running at full speed. A too-tight belt can result in unintentional tine movement when the lever is in the Neutral (released) position.

- Check belt tension after the first two hours of break-in operation and after every 10 operating hours.
- At the end of each tilling season, check the belt for cracks, cuts or frayed edges, and replace it as soon as possible.

To Check Belt Tension:

1. Stop engine, wait for all parts to stop moving and disconnect spark plug wire.
2. With the forward and reverse lever in an open (released) position, measure the distance of travel in the lever before the belt fully engages the pulley, if it is more than 5/8" of an inch the belt is too loose and needs tightened.

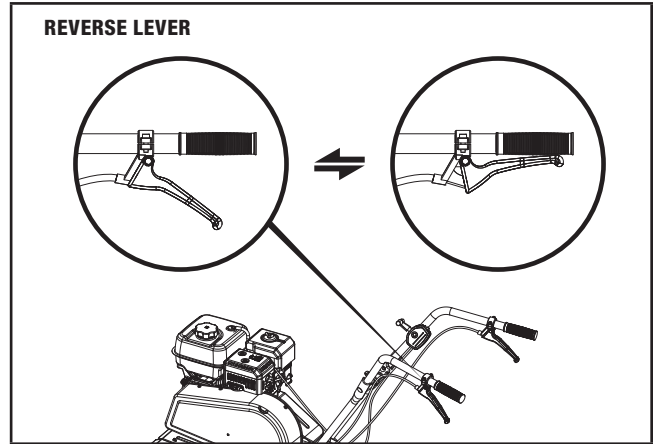
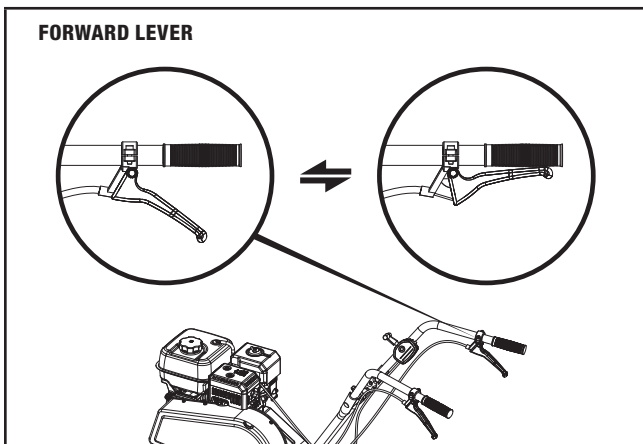

3. To adjust the length of the spring.
 - 3a. Un-thread the hex nut halfway up the adjustment screw.
 - 3b. Unhook the top of the spring from the lever.
 - 3c. Use pliers to prevent the adjuster from turning and turn the slotted screw located inside the spring clockwise (viewed from operator's position) to increase tension on the spring. Turn the screw counter-clockwise to decrease tension. Once adjusted, reattach the spring to the lever.
 - 3d. Repeat Steps 2 and 3 to re-measure the length of the spring. When the second measurement is between 1/16 in. to 3/16 in. (2 to 5 mm) longer than the first measurement, re-tighten the hex nut against the top of the adjuster.

Replacement Belt Information

If the drive belt needs to be replaced, refer to the parts list for information. The procedure requires average mechanical ability and commonly available tools to change or replace.

| | LENGTH (inches) | WIDTH (inches) |
|---------|-------------------|---------------------|
| 17X1070 | 24 in. ± 0.24 in. | 0.95 in. ± 0.01 in. |
| Z914 | 29 in. ± 0.20 in. | 0.70 in. ± 0.02 in. |

| | LENGTH (mm) | WIDTH (mm) |
|---------|-----------------|----------------|
| 17X1070 | 1070.0 ± 8.0 mm | 17.0 ± 0.40 mm |
| Z914 | 914.0 ± 8.0 mm | 9.5 ± 0.50 mm |

Belt Tension Adjustment

Loosen the nuts holding the tine engagement cable to the tiller body. Move the cable away from the drive pulley to tighten belt tension or toward the drive pulley to decrease belt tension, re-tighten the nuts.

To increase belt tension:

1. Turn jam nut clockwise in 1/8 in. (3 mm) increments.
2. Test the travel distance of the engagement lever again to see if travel before full engagement is less than 5/8 of an inch. If it is still more than 5/8 readjust the cable. Note, if there is no more cable adjustment left the belt has become stretched and will need replaced.

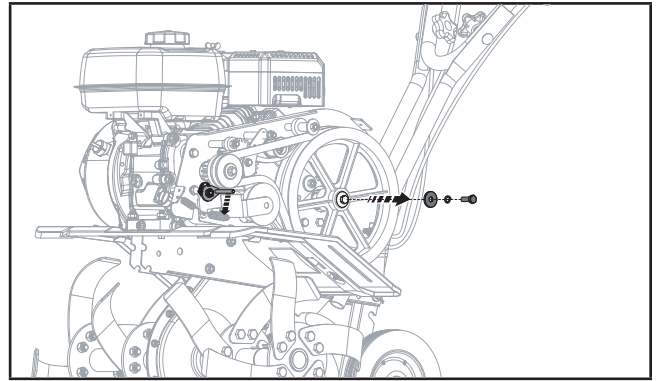
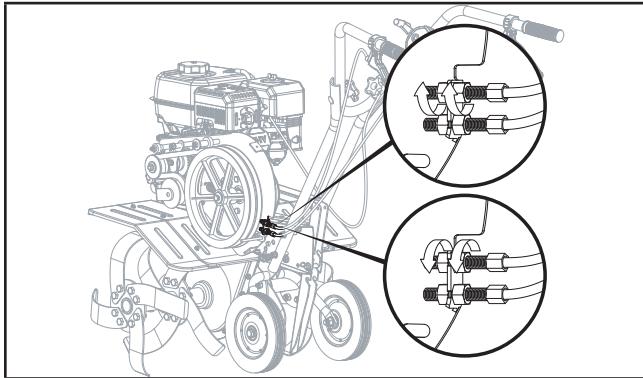

6. Remove the forward direction tine belt.

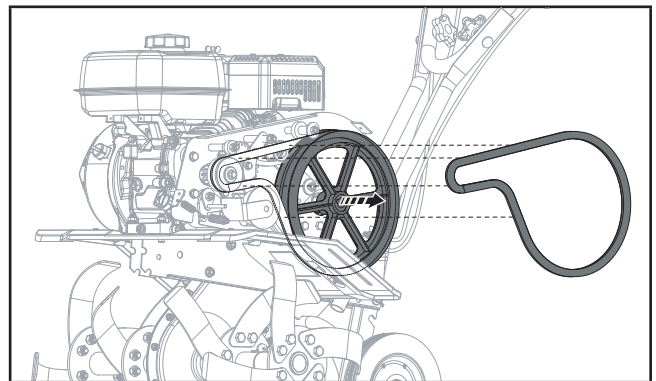

7. Remove belt guide bracket for reverse tine belt.

Change Forward/Reverse Tine Drive Belts

1. Turn off engine. Engine must cool completely before proceeding.
2. Remove spark plug wire and secure away from spark plug.
3. Remove belt guard.
4. Loosen belt Tension by removing tine engagement cables.

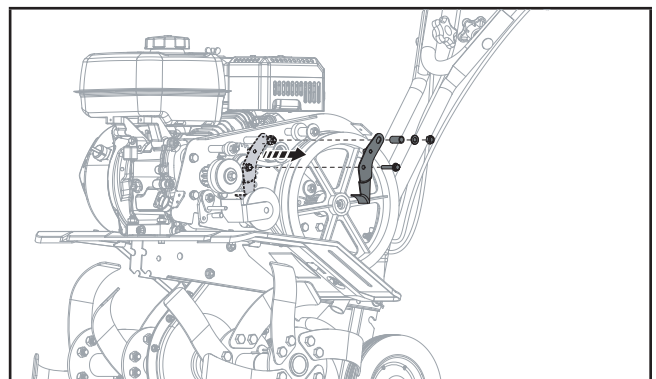
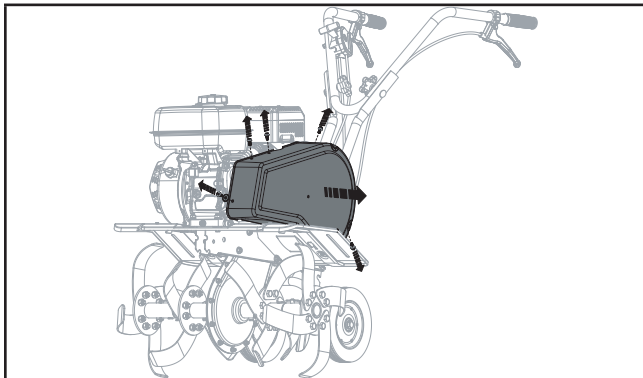

8. Remove drive pulley and reverse belt.
9. Install new belts and replace drive components.
10. Tension belt control cables as per belt tension adjustment instructions.
11. Replace belt cover

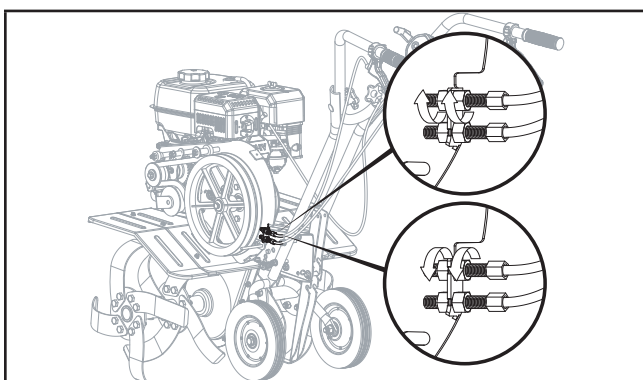

5. Remove the bolt holding the main drive pulley:

⚠ WARNING

The tines or wheels should not rotate with the engine running, the depth regulator set at transport height (lowest height) and the drive lever not engaged.

Engine Cleaning

Keeping the engine clean will help to ensure smooth operation and prevent damage from overheating. Refer to the Engine

Owner's Manual for engine cleaning service intervals and instructions. Be sure that the muffler is cool before servicing the engine.

Air Cleaner Service

The air cleaner filters dirt and dust out of the air before it enters the carburetor. Operating the engine with a dirty, clogged air filter can cause poor performance and damage to the engine. Never operate the engine without the air cleaner installed. Inspect and service the air cleaner more often if operating in very dusty or dirty conditions. Refer to the engine Owner's Manual for air cleaner service intervals and instructions.

Engine Oil Service

Check the engine oil level before each use and after every five hours of continuous operation. Running the engine when it is low on oil will quickly ruin the engine.

It is recommended that you change the motor oil after every 10 hours of operation and even sooner when operating in extremely dirty or dusty conditions.

A. To Check the Engine Oil Level:

1. Park the tiller on a level area and shut off the engine.
2. Level the engine (use the Depth Regulator Lever to adjust the engine angle).
3. Clean around the oil dipstick to prevent dirt from falling into the crankcase.
4. On engines with a dipstick, remove it and wipe it clean. Reinsert the dipstick, tighten it securely, and remove it. Add oil as needed to bring the level up to the FULL mark. Wipe dipstick clean each time oil level is checked. Do not overfill. Tighten dipstick securely.

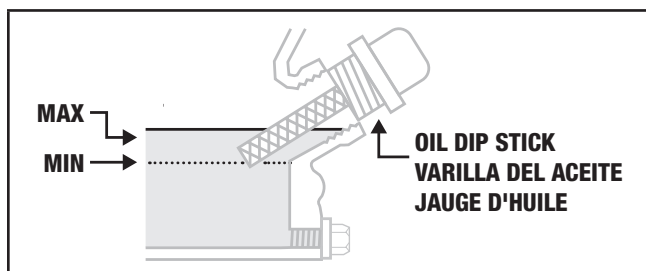

B. To Change the Engine Oil:

⚠ CAUTION

DO NOT attempt to crank or start the engine before it has been properly filled with the recommended type and amount of oil. Damage to the tiller as a result of failure to follow these instructions will void your warranty.

🗨 NOTICE

The recommended oil type is **10W-30 automotive oil**.

1. Place tiller on a flat, level surface.
2. Clean around the oil drain plug to prevent dirt from falling into the crankcase. Remove oil drain plug.
3. Allow the engine oil to drain.
4. Replace oil drain bolt.
5. Reinstall the wheel.
6. Refill the with engine oil through the dipstick with funnel and replenish the fuel tank with gasoline.

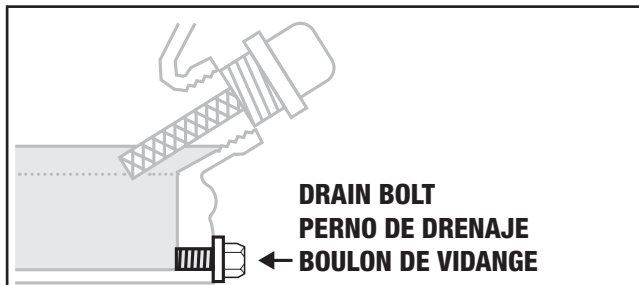
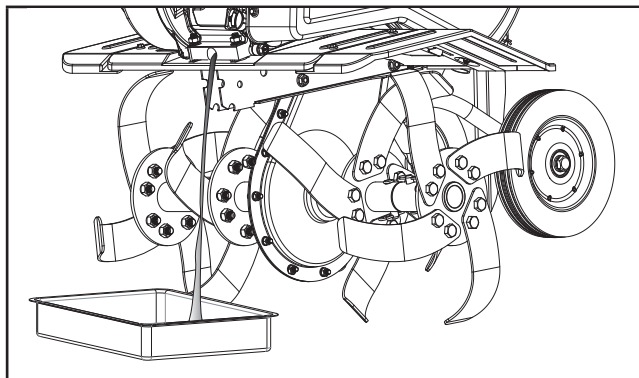

🗨 NOTICE

Once oil has been added, a visual check should show oil about 1-2 threads from running out of the fill hole.

If using the dipstick to check oil level, DO NOT screw in the dipstick while checking.

🗨 NOTICE

Check oil often during the break-in period. Refer to the [Maintenance](#) section for recommended service intervals.

⚠ CAUTION

The engine is equipped with a low oil shut-off and will stop when the oil level in the crankcase falls below the threshold level.

NOTICE

We consider the first 5 hours of run time to be the break-in period for the engine. During the break in period we recommend using standard automotive non-synthetic blended oils. After the break in period synthetic oil can be used but is not required. Adjusting throttle setting will increase/decrease engine speed helping to seat piston rings. Avoid bogging or lugging the engine down and avoid prolonged running at constant RPM. After the 5 hour break-in period, change the oil. Using synthetic oil does not increase the recommended oil change interval.

NOTICE

Weather will affect engine oil and engine performance. Change the type of engine oil used based on weather conditions to suit the engine needs.

NOTICE

Synthetic oil may be used after the 5 hour initial break-in period. Using synthetic oil does not increase the recommended oil change interval. Full synthetic 5W-30 oil will aid in starting in cold ambient <math><5^{\circ}\text{C}</math> (41° F).

Air Cleaner Maintenance

A dirty air cleaner can restrict air flowing into the carburetor. To keep the carburetor in good working conditions, please service the air cleaner periodically. If operating the engine in extremely dusty area, servicing should be done more often.

WARNING

Never clean the air cleaner element with gasoline or low flash-point detergents, an explosion may happen.

NOTICE

Never run the engine without an air cleaner. Dirty air entering the engine can speed up engine wear.

1. Remove the air cleaner cover and take the element out.
2. Paper element: Wash the element with home detergents and warm water (or non-flammable or high flash-point cleansing solvents) and dry.
Foam element: Soak in clean engine oil until saturated. Squeeze out excess oil; otherwise, the engine will smoke when starting.
3. Clean the air cleaner cover and inner surface with a damp cloth, be careful not to allow dust to enter the carburetor.

4. Reinstall the element and reinstall the air cleaner cover.

Spark Plug Service

Spark plug type: F6RTC/F6TC/F7RTC/F7TC

For normal engine operation, ensure the spark plug gap is correct and check for carbon deposit around the spark plug.

1. Remove the spark plug cap.
2. Clear away dirt around the spark plug base.
3. Dismantle the spark plug with a spark plug wrench.
4. Visually check the spark plug. Clean with a steel brush. If the insulator is damaged, replace the spark plug.
5. Measure the spark plug clearance with a spark plug gap gauge. The clearance should be 0.7-0.8 mm. If adjustment is necessary, bend the side electrode carefully.
6. Check if the spark plug gasket is in good condition. To prevent cross threading, screw in by hand.
7. Screw in the spark plug to the bottom first by hand and then screw in by a spark plug wrench and compress the gasket.
 - 7a. If a new spark plug is used, twist another 1/2 turn after compressing the gasket.
 - 7b. If reinstalling a used spark plug, only twist another 1/8-1/4 turn.

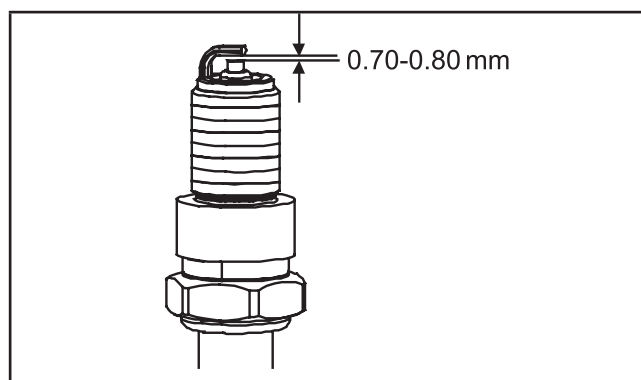
**WARNING**

Don't touch the muffler when the engine is running or hot.

NOTICE

The spark plug must be tightened securely, or it may become very hot and damage the engine.

Spark Arrester Screen Service

If the engine muffler is equipped with a spark arrester screen, remove and clean it according to the service intervals.

TRANSPORTATION AND STORAGE

Transport with the fuel valve turned the “OFF” position. Transport or store the engine when it is cool to avoid getting burns or starting a fire.

NOTICE

Do not tilt the engine to avoid fuel spill. Spilled fuel or fuel vapor may ignite and cause fire.

Off-Season Storage

When the tiller won't be used for an extended period, prepare it for storage as follows:

1. Make sure the storage area is dry and free of dust.
2. Clean the tiller and engine.
3. Do routine tiller lubrication and check for loose parts and hardware.
4. Turn the fuel valve to “OFF” position, set a proper container under the carburetor.
5. Drain the oil out of the gasoline engine.
6. Remove the spark plug. Place about a spoon of fresh engine oil into the cylinder. Crank the engine to distribute engine oil evenly.
7. Reinstall the spark plug.
8. Store unit in a clean, dry area.
9. Never store the tiller with fuel in the fuel tank in an enclosed area where gas fumes could reach an open flame or spark, or where ignition sources are present (space heaters, hot water heaters, furnaces, etc.)
10. Loosen the oil drain bolt and completely drain the gasoline out of the carburetor into a proper container and screw the oil drain bolt down. Remove the sediment bowl after closing fuel cock, and completely pour the gasoline out the sediment bowl. Finally reinstall the sediment bowl back and screw it down.

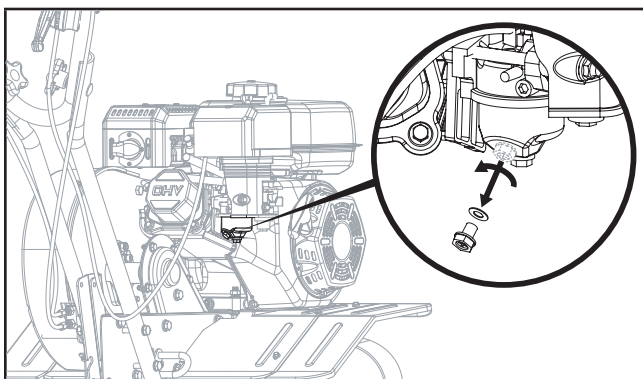

WARNING

Fuel is extremely flammable and explosive under certain conditions. Keep smoke, fire and spark away from operating site.

Removing from Storage

1 MONTH

- No repair needed.

1-2 MONTHS

- Drain the used gasoline and add fresh gasoline.

2 MONTHS TO 1 YEAR

- Drain the used gasoline and add fresh gasoline.
- Drain the gasoline out of the carburetor cup.
- Drain the gasoline out of the sediment bowl.

OVER 1 YEAR

- Drain the used gasoline add fresh gasoline.
- Drain the gasoline out of the carburetor cup.
- Drain the gasoline out of the sediment bowl.

SPECIFICATIONS

Tiller Specifications

| | |
|---------------------------------|----------------------------|
| Model | 100379 |
| Tine Diameter | 13.8 in. (350 mm) |
| Tilling Width (in.) | 16-22 in. (313.5-558.8 mm) |
| Tilling Depth (in.) | 8 in. (203 mm) |
| Tilling Depth Adjustments | 1.4 in. (35 mm) Increments |
| Wheel Diameter | 8 in. (20.3 cm) |
| Net Weight | 120 lb. (54 kg) |
| Length | 47.2 in. (120 cm) |
| Width | 23.6 in. (60 cm) |
| Height | 37.8 in. (96 cm) |

Engine Specifications

| | |
|---------------------|------------------|
| Displacement | 212 cc |
| Type | 4-Stroke OHV |
| Fuel Capacity | 0.9 gal. (3.2 L) |
| Oil Capacity | 0.6 qt. (0.6 L) |
| Oil Type | 10W-30 |

NOTICE

Weather will affect engine oil and engine performance.
Change the type of engine oil used based on weather conditions to suit the engine needs.

Fuel Specifications

Use regular unleaded gasoline with a minimum octane rating of 85 and an ethanol content of 10% or less by volume. DO NOT USE E15 or E85. DO NOT OVERFILL.

Parts Diagram

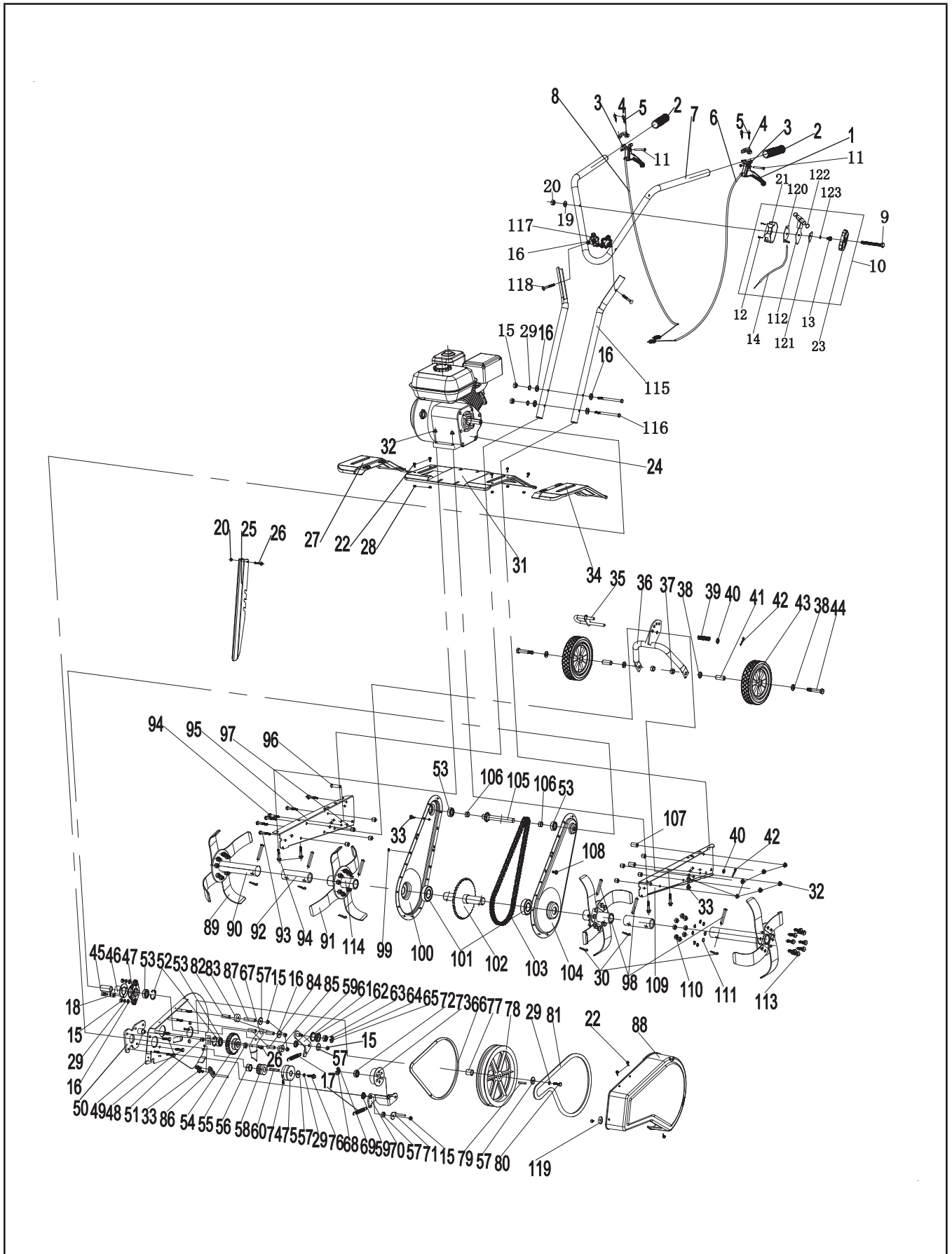

Parts List

| # | Part Number | Description | Qty. |
|----|---------------|------------------------------------|------|
| 1 | 100379-001 | Clutch Lever | 2 |
| 2 | 100379-002 | Handlebar Grip | 2 |
| 3 | 100379-003.2 | Bottom Clutch Lever Holder, Black | 2 |
| 4 | 100379-004.2 | Upper Clutch Lever Holder, Black | 2 |
| 5 | 100379-005 | Screw M6 × 20 | 4 |
| 6 | 100379-006 | Reverse Clutch Cable | 1 |
| 7 | 100379-007.2 | Handlebar, Black | 1 |
| 8 | 100379-008 | Forward Clutch Cable | 1 |
| 9 | 100379-009 | Bolt M6 × 60 | 1 |
| 10 | 100379-010 | Throttle Switch | 1 |
| 11 | 100379-011 | Suit Rivet | 2 |
| 12 | 100379-012 | Self-tapping Screw M3 × 20 | 2 |
| 13 | 100379-013 | Rivet | 1 |
| 14 | 100379-014 | Throttle Cable | 1 |
| 15 | 100379-015 | Locknut M8 | 9 |
| 16 | 100379-016 | Flat Washer Ø8 | 9 |
| 17 | 100379-017 | Tension Spring | 2 |
| 18 | 100379-018 | Combination Screw M6 × 16 | 3 |
| 19 | 100379-019 | Flat Washer Ø6 | 1 |
| 20 | 100379-020 | Locknut M6 | 2 |
| 21 | 100379-021 | Left Throttle Switch Box | 1 |
| 22 | 100379-022 | Bolt M5 × 12 | 11 |
| 23 | 100379-023 | Right Throttle Switch Box | 1 |
| 24 | 100379-024 | Engine | 1 |
| 25 | 100379-025.2 | Resistance Pole, Black | 1 |
| 26 | 100379-026 | Flange Bolt M6 × 35 | 2 |
| 27 | 100379-027.48 | Left Extension Fenderboard, Yellow | 1 |
| 28 | 100379-028 | Flange Locknut M5 | 6 |
| 29 | 100379-029 | Spring Washer Ø8 | 6 |
| 30 | 100379-030 | B Uncork Pin Ø2.5 × 37 | 6 |
| 31 | 100379-031.48 | Fenderboard, Yellow | 1 |
| 32 | 100379-032 | Flange Locknut M8 | 12 |
| 33 | 100379-033 | Flange Bolt M8 × 16 | 5 |
| 34 | 100379-034.48 | Right Extension Fenderboard | 1 |
| 35 | 100379-035 | Wheel Adjusting Pole | 1 |
| 36 | 100379-036.2 | Wheel Bracket, Black | 1 |

| # | Part Number | Description | Qty. |
|----|---------------|---------------------------|------|
| 37 | 100379-037 | Locknut M12 | 2 |
| 38 | 100379-038 | Flat Washer Ø12 | 4 |
| 39 | 100379-039 | Adjusting Press Spring | 1 |
| 40 | 100379-040 | Gasket Ø10 | 2 |
| 41 | 100379-041 | Axle Bushing | 2 |
| 42 | 100379-042 | B Uncork Pin Ø2 × 37 | 2 |
| 43 | 100379-043.48 | Wheel 8", Yellow | 2 |
| 44 | 100379-044 | Bolt M12 × 65 | 2 |
| 45 | 100379-045 | Bushing, Fixation Board | 1 |
| 46 | 100379-046 | Flange Plate | 1 |
| 47 | 100379-047 | Bearing Seat | 1 |
| 48 | 100379-048 | Flange Bolt M8 × 25 | 4 |
| 49 | 100379-049.2 | Fixation Board, Black | 1 |
| 50 | 100379-050 | Fixation Board, Big Gear | 1 |
| 51 | 100379-051 | Bushing, Big Gear | 1 |
| 52 | 100379-052 | Circlip 35 | 2 |
| 53 | 100379-053 | Bearing 6003 | 4 |
| 54 | 100379-054 | Big Gear | 1 |
| 55 | 100379-055 | Fixation Washer, Big Gear | 1 |
| 56 | 100379-056 | Bushing, Small Belt Wheel | 1 |
| 57 | 100379-057 | Flat Washer Ø8 × Ø28 × 3 | 5 |
| 58 | 100379-058 | Small Gear | 1 |
| 59 | 100379-059 | Tension Bushing | 2 |
| 60 | 100379-060 | Flat Key 4.78 × 5 × 45 | 1 |
| 61 | 100379-061 | Reverse Tension Arm | 1 |
| 62 | 100379-062 | Tension Pulley (Reverse) | 1 |
| 63 | 100379-063 | Bearing 628 | 1 |
| 64 | 100379-064 | Circlip 8 | 1 |
| 65 | 100379-065 | Circlip 24 | 1 |
| 66 | 100379-066 | Reverse Belt Z914Li | 1 |
| 67 | 100379-067 | Belt Guard Assembly | 1 |
| 68 | 100379-068 | Circlip 12 | 1 |
| 69 | 100379-069 | Circlip 28 | 1 |
| 70 | 100379-070 | Forward Tension Arm | 1 |
| 71 | 100379-071 | Forward Belt Baffle | 1 |
| 72 | 100379-072 | Bearing 6001 | 1 |
| 73 | 100379-073 | Forward Tension Pulley | 1 |
| 74 | 100379-074 | Screw M6 × 16 | 1 |

| # | Part Number | Description | Qty. |
|-----|---------------|---|------|
| 75 | 100379-075 | Forward Small Belt Wheel | 1 |
| 76 | 100379-076 | Bolt 5/16,1"-24 | 1 |
| 77 | 100379-077 | Bushing, Big Belt Wheel | 1 |
| 78 | 100379-078 | Big Belt Wheel | 1 |
| 79 | 100379-079 | Flat Key 5 × 5 × 35 | 1 |
| 80 | 100379-080 | Bolt M8 × 25 | 1 |
| 81 | 100379-081 | Forward Belt 17 × 1070 | 1 |
| 82 | 100379-082 | Back Belt Block Tube 1 | 2 |
| 83 | 100379-083 | Tension Bushing | 1 |
| 84 | 100379-084 | Front Belt Block Tube | 2 |
| 85 | 100379-085 | Belt Block Bushing | 1 |
| 86 | 100379-086 | Big Belt Block Pole | 1 |
| 87 | 100379-087 | Back Belt Block Tube 2 | 1 |
| 88 | 100379-088 | Belt Guard | 1 |
| 89 | 100379-089.2 | Left Blade, Black | 8 |
| 90 | 100379-090.2 | Blade Holder 2, Black | 2 |
| 91 | 100379-091.2 | Right Blade, Black | 8 |
| 92 | 100379-092.2 | To Take Over, Black | 2 |
| 93 | 100379-093 | Flange Bolt M8 × 45 | 4 |
| 94 | 100379-094 | Flange Bolt M8 × 40 | 6 |
| 95 | 100379-095.48 | Right Base, Yellow | 1 |
| 96 | 100379-096 | Pin Roll Ø10 × 40 | 1 |
| 97 | 100379-097 | Bushing, Case | 8 |
| 98 | 100379-098 | Pin Roll Ø10 × 50 | 6 |
| 99 | 100379-099 | Flange Locknut M6 | 16 |
| 100 | 100379-100.2 | Right Case, Black | 1 |
| 101 | 100379-101 | Bearing 6206 | 2 |
| 102 | 100379-102 | Big Chain Wheel | 1 |
| 103 | 100379-103 | Chain 08B-1-80 | 1 |
| 104 | 100379-104.2 | Left Case, Black | 1 |
| 105 | 100379-105 | Small Chain Wheel | 1 |
| 106 | 100379-106 | Bushing, Small Chain Wheel | 2 |
| 107 | 100379-107 | Bushing, Base | 2 |
| 108 | 100379-108 | Flange Screw M6 × 16 | 16 |
| 109 | 100379-109.48 | Left Base, Yellow | 1 |
| 110 | 100379-110 | Nut M10 × 1 | 32 |
| 111 | 100379-111 | Spring Washer Ø10 | 32 |
| 112 | 100379-112.1 | The Accelerator Components In Hand, Black | 1 |
| 113 | 100379-113 | Bolt M10 × 1 × 25 | 32 |
| 114 | 100379-114.2 | Blade Holder 1, Black | 2 |

| # | Part Number | Description | Qty. |
|-----|--------------|---|------|
| 115 | 100379-115.2 | Handlebar Arm, Black | 2 |
| 116 | 100379-116 | Outer Hex Bolt M8 × 120 | 2 |
| 117 | 100379-117 | Handlebar Knob | 2 |
| 118 | 100379-118 | Round Head Square Neck Ccrew M8 × 50 | 2 |
| 119 | 100379-119 | Flat Washer Ø5 × Ø16 × 1.5 | 1 |
| 120 | 100379-120 | The Throttle Switch Fixed Plate | 1 |
| 121 | 100379-121 | Positioning Plate | 1 |
| 122 | 100379-122 | Plug | 2 |
| 123 | 100379-123 | Saddle Elastic Washer Ø10 | 1 |

Engine Parts Diagram

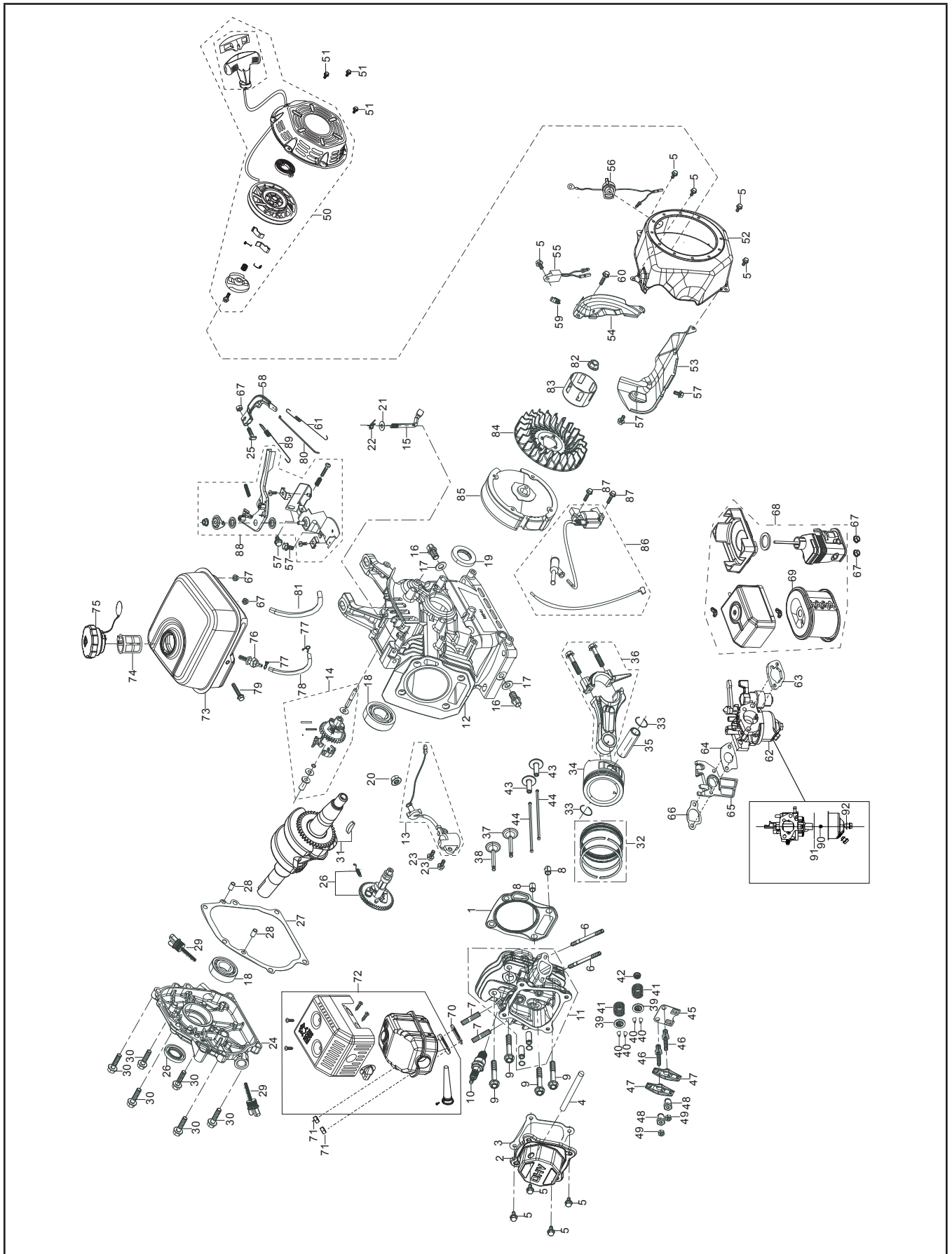

Engine Parts List

| # | Part Number | Description | Qty. |
|----|--------------------|--|------|
| 1 | 12131-Z950110-0000 | Gasket, Cylinder Head | 1 |
| 2 | 12410-Z440110-0099 | Cover Subassembly, Cylinder Head | 1 |
| 3 | 12004-Z440110-0000 | Gasket, Cylinder Head Cover | 1 |
| 4 | 17004-Z440110-0000 | Tube, Breather, Ø8 x Ø12 x 90 | 1 |
| 5 | 90001-0612-01 | Bolt, M6 x 12 | 9 |
| 6 | 90204-Z010310-0000 | Stud, M6 x 113 | 2 |
| 7 | 90203-Z010110-0000 | Stud, M8 x 34 | 2 |
| 8 | 90502-1114-00 | Pin, d=11 L=14 | 2 |
| 9 | 12003-Z010110-0000 | Bolt, Cylinder Head, M8 x 60 | 4 |
| 10 | 30010-Z010110-0000 | Plug, Spark, M14 x 1.25-6e L=81, F6RTC | 1 |
| 11 | 12140-Z810210-0000 | Head Subassembly, Cylinder | 1 |
| 12 | 11310-Z530420-0099 | Crankcase Subassembly | 1 |
| 13 | 37060-Z010120-0000 | Sensor, Engine Oil | 1 |
| 14 | 16400-Z010110-0000 | Gear Assembly, Governor | 1 |
| 15 | 16061-Z010110-0000 | Arm, Governor | 1 |
| 16 | 11007-Z010110-0000 | Bolt, Drain Plug, M10 x 1.25 x 15 | 2 |
| 17 | 90408-Z010110-0000 | Washer, Ø10 x 1.25 x Ø15 | 2 |
| 18 | 90547-0205-CL | Bearing, Ø25 x Ø52 x 15 | 2 |
| 19 | 90682-Z300110-0000 | Seal, Oil d=25 D=41.25 b=6 | 2 |
| 20 | 90305-Z010210-01 | Nut, M10 | 1 |
| 21 | 90408-Z010210-0000 | Washer, Ø6.2 x Ø15 x 0.6 | 1 |
| 22 | 90501-Z010110-0000 | Cotter Pin, Ø1.2 L=26 | 1 |
| 23 | 90001-0614-01 | Bolt, M6 x 14 | 2 |
| 24 | 11411-Z440310-0000 | Cover, Crankcase | 1 |
| 25 | 16072-Z010110-0000 | Bolt, Governor Support, M6 x 21 | 1 |
| 26 | 14200-530210-0099 | Camshaft Assembly | 1 |
| 27 | 11001-Z440110-0000 | Gasket, Crankcase | 1 |
| 28 | 90502-0912-00 | Pin, d=9 L=12 | 2 |
| 29 | 15010-Z290110-0B00 | Dipstick Subassembly, Oil | 2 |
| 30 | 90001-0832-01 | Bolt, M8 x 32 | 6 |

| # | Part Number | Description | Qty. |
|----|--------------------|-----------------------------------|------|
| 31 | 13300-Z533210-0000 | Crankshaft Assembly | 1 |
| 32 | 13200-Z140210-0099 | Piston Ring Assembly | 1 |
| 33 | 13122-Z010110-0000 | Clip, Piston Pin | 2 |
| 34 | 13111-Z140220-0099 | Piston | 1 |
| 35 | 13121-Z010110-0000 | Pin, Piston | 1 |
| 36 | 13010-Z440210-0099 | Rod, Connecting | 1 |
| 37 | 12110-Z810110-0099 | Intake Valve | 1 |
| 38 | 12110-Z810120-0099 | Exhaust Valve | 1 |
| 39 | 12112-Z810210-0000 | Seat, Valve Spring | 2 |
| 40 | 12109-Z810110-0000 | Lock Clamp, Valve | 4 |
| 41 | 12103-Z010110-0000 | Spring, Valve | 2 |
| 42 | 12101-Z810210-0000 | Guide, Seal | 1 |
| 43 | 14081-Z040110-0000 | Tappet, Valve | 2 |
| 44 | 14071-Z440110-0000 | Lifter, Valve | 2 |
| 45 | 14090-Z010110-0000 | Plate Subassembly, Lifter Stopper | 1 |
| 46 | 14313-Z010110-0000 | Bolt, Valve Adjusting | 2 |
| 47 | 14311-Z010110-0000 | Rocker, Valve | 2 |
| 48 | 14314-Z010110-0000 | Nut, Valve Adjusting | 2 |
| 49 | 14312-Z010110-0000 | Nut, Valve Lock | 2 |
| 50 | 28200-Z300110-H600 | Starter Assembly, Recoil, Black | 1 |
| 51 | 90001-0608-01 | Bolt, M6 x 8 | 3 |
| 52 | 28110-Z010410-0B00 | Shroud, PMS 109 C | 1 |
| 53 | 19304-Z010610-0000 | Shroud, Cylinder Body | 1 |
| 54 | 19340-Z010120-0000 | Shield, Lower | 1 |
| 55 | 37050-Z010210-0000 | Protector, Oil | 1 |
| 56 | 35540-Z060140-Q200 | Switch Subassembly, Stop Engine | 1 |
| 57 | 90001-0610-01 | Bolt, M6 x 10 | 4 |
| 58 | 16070-Z010110-0000 | Support Subassembly, Governor | 1 |
| 59 | 90740-Z010110-0000 | Collar, Ø15 | 1 |
| 60 | 90001-0616-01 | Bolt, M6 x 16 | 1 |
| 61 | 16012-Z010110-0000 | Spring, Throttle Valve Returning | 1 |
| 62 | 16100-Z530610-0709 | Carburetor Assembly | 1 |
| 63 | 17001-Z010210-0000 | Gasket, Air Cleaner | 1 |
| 64 | 16001-Z010110-0000 | Gasket, Carburetor | 1 |
| 65 | 16003-Z010110-0000 | Plate, Carburetor Insulator | 1 |
| 66 | 16002-Z050110-0000 | Gasket, Carburetor Insulator | 1 |
| 67 | 90305-0600-31 | Nut, M6 | 5 |

| # | Part Number | Description | Qty. |
|----|--------------------|--|------|
| 68 | 17100-Z010210-0000 | Air Cleaner Assembly, Black | 1 |
| 69 | 17150-Z010110-0000 | Element, Air Cleaner | 1 |
| 70 | 18001-Z440110-0000 | Gasket, Exhaust Outlet | 1 |
| 71 | 90303-0800-31 | Nut, M8 | 2 |
| 72 | 18100-Z012610-H300 | Muffler Assembly, Black | 1 |
| 73 | 16620-Z440410-H600 | Fuel Tank | 1 |
| 74 | 16652-Z010710-0000 | Strainer, Fuel | 1 |
| 75 | 16730-Z440210-LK00 | Fue Tank Cap, Black | 1 |
| 76 | 16680-Z010110-0000 | Outlet Subassembly, Fuel Tank Oil | 1 |
| 77 | 90740-Z010210-0000 | Collar, Ø7.5 | 2 |
| 78 | 90686-Z010710-0000 | Tube, Fuel, Ø4.5 x Ø8.5 x 160 | 1 |
| 79 | 90001-0630-01 | Bolt, M6 x 30 | 1 |
| 80 | 16062-Z010110-0000 | Rod, Gouverneur | 1 |
| 81 | 30431-Z010110-0000 | Jacket, Rubber | 1 |
| 82 | 13501-Z010110-0000 | Nut, Flywheel, M14 x 1.5 | 1 |
| 83 | 28002-Z010310-0000 | Pulley, Starter | 1 |
| 84 | 19352-Z440110-0000 | Cooling Fan | 1 |
| 85 | 13510-Z440410-0000 | Flywheel Subassembly | 1 |
| 86 | 30400-Z440110-0100 | Coil, Ignition | 1 |
| 87 | 90001-0625-01 | Bolt, M6 x 25 | 2 |
| 88 | 16520-Z010430-0001 | Control Assembly, Throttle | 1 |
| 89 | 16063-Z050510-0000 | Spring, Governor | 1 |
| 90 | 16161-Z030310-0000 | Main Jet, H128 x 0.91, Standard | 1 |
| | 16161-Z010310-0000 | Main Jet, H128 x 0.94, Altitude 3000-6000 feet | / |
| | 16161-Z050210-0000 | Main Jet, H128 x 0.97, Altitude 6000-8000 feet | / |
| 91 | 16112-Z010110-0000 | Seal Ring, Float | 1 |
| 92 | 90681-Z010510-0000 | Seal Ring | 1 |

TROUBLESHOOTING

| Problem | Cause | Solution |
|--------------------------------|---|---|
| Engine does not start | Spark plug wire disconnected. | Reconnect wire. |
| | Engine Throttle Control Lever incorrectly set. | Put lever in START position. |
| | Fuel tank empty. | Add fuel. |
| | Choke control (if so equipped) in incorrect position. | Move to CHOKE position. |
| | Stale gasoline. | Drain fuel and add fresh fuel. |
| | Dirty air filter. | Clean or replace filter. |
| | Defective or incorrectly gapped spark plug. | Inspect spark plug. |
| | Carburetor out of adjustment. | Contact Technical Support Team. |
| | Misadjusted throttle control. | Contact Technical Support Team. |
| | Dirt or water in fuel tank. | Contact Technical Support Team. |
| Engine runs poorly | Defective or incorrectly gapped spark plug. | Inspect spark plug. |
| | Dirty air filter(s). | Clean or replace. |
| | Carburetor out of adjustment. | Contact Technical Support Team. |
| | Stale gasoline. | Replace with fresh gasoline. |
| | Dirt or water in fuel tank. | Contact Technical Support Team. |
| | Engine cooling system clogged. | Clean air cooling system. |
| Engine overheats | Engine cooling system clogged. | Clean air cooling area. |
| | Carburetor out of adjustment. | Contact Technical Support Team. |
| | Oil level is low. | Check oil level. |
| Engine does not shut off | Misadjusted throttle control or ignition switch. | Contact Technical Support Team. |
| Wheels and Tines will not turn | Improper use of controls. | Review controls section. |
| | Worn, broken, or misadjusted drive belt(s). | See "Checking and Adjusting Forward Drive Belt Tension" or "Belt Tension Adjustment". |
| | Internal transmission wear or damage. | Contact local dealer or the factory. |
| | Bolt loose in transmission pulley. | Tighten bolt. |
| Tines turn, but wheels don't | Wheel Drive Pins not in WHEEL DRIVE. | See "Wheel Drive Pins". |
| | Bolt loose in transmission pulley. | Tighten bolt. |
| | Internal transmission wear or damage. | Contact Technical Support Team. |
| Wheels Turn, but tines don't | Tine holder mounting hardware missing. | Replace hardware. |
| | Bolt loose in transmission pulley. | Tighten bolt. |
| | Internal transmission wear or damage. | Contact Technical Support Team. |
| Poor tilling performance | Worn tines. | See "Tines" section. |
| | Improper Depth Regulator setting. | See "Depth Regulator Lever Adjustment". |
| | Incorrect throttle setting. | Adjust throttle on engine or speed control on handelbar to highest setting. |
| | Forward Drive Belt slipping. | See "Checking and Adjusting Forward Drive Belt Tension" or "Belt Tension Adjustment". |

Difficulty Starting Engine (Recoil)

| Problem | Cause | Solution | |
|---|---|--|--|
| Something wrong with the fuel system: fuel supply is not smooth or no fuel supply | There is no enough fuel in fuel tank and fuel cock is closed. | Fill fuel, open fuel cock. | |
| | Air vent in the fuel filler cap is clogged. | Dredge air vent. | |
| | Fuel cock is clogged. | Clean first and then dredge. | |
| | Improper or clogged main oil flow hole. | Readjust or clean. Blow to clear through. | |
| | Needle valve is not closed properly or start hole is clogged. | Dismantle needle valve and repair, clean. Blow to get through. | |
| | Float is damaged or sticking. | Repair float. | |
| | Fuel is too filthy or deteriorated. | Replace. | |
| | There is water in fuel. | Replace. | |
| | Too much fuel in engine. | Drain extra fuel. Dry up spark plug electrodes. | |
| | Wrong fuel brand. | Select proper fuel brand corresponding with the requirements. | |
| No spark | Too much carbon deposit and dirt around electrodes. | Clear carbon deposits. | |
| | Too much carbon deposit and dirt around electrodes. | Replace spark plug. | |
| | Too much carbon deposit and dirt around electrodes. | Adjust to proper value. | |
| Abnormal cylinder compression | Piston ring is at its wear limit. | Replace. | |
| | Piston ring is broken. | Replace. | |
| | Piston ring is sticking. | Clear up carbon fouling. | |
| | Spark plug is not installed tightly or gasket is missing. | Tighten with a gasket in. | |
| | Air leakage between cylinder block and cylinder head. | Check cylinder gasket and the flatness of the surface where the cylinder block contacts the cylinder head. | |
| | | Tighten cylinder head bolts in stipulated order to stipulated torque. | |
| Air leakage in the valves. | Check valve clearance and tightness. Repair if necessary. | | |

If engine still doesn't start, contact our Technical Support Team for service and/or repair.

⚠ WARNING

- When testing the spark plug, never hold the high-voltage wire of the spark plug with wet hand.
- Make sure there is no spilled fuel outside the engine and that the spark plug isn't covered with fuel.
- To prevent fire, keep sparks far away from the spark plug mounting hole.

Gasoline Engine: No Power

| Problem | Cause | Solution |
|--|---|-----------------------------------|
| When increasing throttle, speed increase slow (or even decreases and stops running)/poor compression | Air in fuel line or fuel line clogged. | Exhaust air or dredge fuel line. |
| | Main oil flow hole is not adjusted properly. | Readjust. |
| | In carburetor, needle valve hole and main oil flow hole clogged. | Clean and blow to clear. |
| | Fuel cock is clogged up. | Clean/replace damaged part. |
| | Too much carbon deposit in combustion chamber. | Clear away. |
| | Too much carbon fouling in muffler and exhaust pipe. | Clear away. |
| | Air cleaner is clogged up. | Clean air cleaner filter element. |
| | Intake pipe is leaking. | Repair or replace. |
| | Piston or cylinder or piston ring is worn. | Replace the worn part. |
| | Air leakage from the surface where the cylinder block contacts the cylinder head. | Replace cylinder gasket. |
| | Too big or too small valve clearance. | Readjust. |
| | Valve tightness is poor. | Repair. |

Gasoline Engine Running Roughly

| Problem | Cause | Solution |
|---------------------|--|--|
| Knocking sound | Piston, cylinder or piston ring is worn excessively. | Replace the worn part. |
| | Piston pin and piston pin hole are worn excessively. | Replace piston or piston pin. |
| | Piston pin and piston pin hole are worn excessively. | Replace tie rod. |
| | Roller bearing for crankshaft main shaft is worn. | Replace roller bearing. |
| Abnormal combustion | Engine is too hot. | Shut down and allow engine to cool off before troubleshooting. |
| | Too much carbon deposit in combustion chamber. | Clear away. |
| | Improper gasoline brand or low gasoline quality. | Replace with qualified gasoline. |
| Spark plug | There is water in float chamber. | Clean. |
| | Improper spark plug electrodes clearance. | Adjust. |
| | Faulty spark plug. | Replace spark plug. |

Stops Suddenly When Running

| Problem | Cause | Solution |
|------------------------------|--|--|
| Stops suddenly while running | Fuel is empty. | Refill fuel. |
| | Carburetor is clogged. | Check fuel line and dredge. |
| | Float is leaking. | Repair. |
| | Needle valve is stuck. | Dismantle float chamber and eliminate. |
| | Spark plug is punctured, or short-circuited by carbon deposit. | Replace spark plug. |
| | Side electrode of spark plug is dropped out. | Replace spark plug. |
| | Ignition coil is punctured or short-circuited. | Replace ignition coil. |
| | Cylinder is seriously scored and valve dropped out. | Repair or replace damaged parts. |

Engine is Overheating

| Problem | Cause | Solution |
|---|---|-------------------------------------|
| Engine is overheating | Oil level is low | Fill oil to proper level |
| | Exhaust pipe blocked up | Clean exhaust pipe |
| | Shroud leaking | Repair damaged part |
| | Cooling fins blocked by foreign matter | Clean cooling fins |
| | Cooling fan loosened and malfunctioning. | Reinstall properly |
| | Connection rod deformation has made piston and cylinder bushing side wear | Replace connection rod |
| | Cylinder or piston or piston ring is worn and made a space between cylinder and crankcase | Replace the worn parts |
| | Crankshaft main bearing burned out | Replace main bearing |
| Beating sound | Piston, piston ring or cylinder is worn | Replace the worn part |
| | Connection rod or piston pin and piston pin hole are worn | Replace the worn part |
| | Crankshaft main neck is worn | Replace the worn bearing |
| | Piston ring is broken | Replace piston ring |
| Metal beating sound when abnormal combustion occurs | Too much carbon deposit in combusting chamber | Clear away carbon deposit |
| | Insufficient electrode clearance of spark plug | Adjust electrode clearance properly |
| Other | Improper valve clearance | Readjust valve clearance properly |
| | Fly wheel is not connected with crankshaft tightly | Tighten |

For further technical support:

Technical Support Team
 Mon-Fri 8:30 AM-5:00 PM (PST/PDT)
 Toll Free 1-877-338-0999
support@championpowerequipment.com

WARRANTY

WARRANTY*

CHAMPION POWER EQUIPMENT
2 YEAR LIMITED WARRANTY

Warranty Qualifications

Champion Power Equipment (CPE) will register this warranty upon receipt of your Warranty Registration Card and a copy of your sales receipt from one of CPE's retail locations as proof of purchase. Please submit your warranty registration and your proof of purchase within ten (10) days of the date of purchase.

Repair/Replacement Warranty

CPE warrants to the original purchaser that the mechanical and electrical components will be free of defects in material and workmanship for a period of two years (parts and labor) from the original date of purchase and 180 days (parts and labor) for commercial and industrial use. Transportation charges on product submitted for repair or replacement under this warranty are the sole responsibility of the purchaser. This warranty only applies to the original purchaser and is not transferable.

Do Not Return The Unit To The Place Of Purchase

Contact CPE's Technical Service and CPE will troubleshoot any issue via phone or e-mail. If the problem is not corrected by this method, CPE will, at its option, authorize evaluation, repair or replacement of the defective part or component at a CPE Service Center. CPE will provide you with a case number for warranty service. Please keep it for future reference. Repairs or replacements without prior authorization, or at an unauthorized repair facility, will not be covered by this warranty.

Warranty Exclusions

This warranty does not cover the following repairs and equipment:

Normal Wear

Products with mechanical and electrical components need periodic parts and service to perform well. This warranty does not cover repair when normal use has exhausted the life of a part or the equipment as a whole.

Installation, Use and Maintenance

This warranty will not apply to parts and/or labor if the product is deemed to have been misused, neglected, involved in an accident, abused, loaded beyond the product's limits, modified, installed improperly or connected incorrectly to any electrical component. Normal maintenance is not covered by this warranty and is not required to be performed at a facility or by a person authorized by CPE.

Other Exclusions

This warranty excludes:

- Cosmetic defects such as paint, decals, etc.
- Wear items such as filter elements, o-rings, etc.
- Accessory parts such as starting batteries, and storage covers.
- Failures due to acts of God and other force majeure events beyond the manufacturer's control.
- Problems caused by parts that are not original Champion Power Equipment parts.

When applicable, this warranty does not apply to products used for prime power in place of a utility.

Limits of Implied Warranty and Consequential Damage

Champion Power Equipment disclaims any obligation to cover any loss of time, use of this product, freight, or any incidental or consequential claim by anyone from using this product. THIS WARRANTY AND THE ATTACHED U.S. EPA, CARB and/or ECCC EMISSION CONTROL SYSTEM WARRANTIES (WHEN APPLICABLE) ARE IN LIEU OF ALL OTHER WARRANTIES, EXPRESS OR IMPLIED, INCLUDING WARRANTIES OF MERCHANTABILITY OR FITNESS FOR A PARTICULAR PURPOSE.

A unit provided as an exchange will be subject to the warranty of the original unit. The length of the warranty governing the exchanged unit will remain calculated by reference to the purchase date of the original unit.

This warranty gives you certain legal rights which may change from state to state or province to province. Your state or province may also have other rights you may be entitled to that are not listed within this warranty.

Contact Information

Address

Champion Power Equipment, Inc.
Customer Service
12039 Smith Ave.
Santa Fe Springs, CA 90670 USA
www.championpowerequipment.com

Customer Service

Mon – Fri 8:30 AM – 5:00 PM (PST/PDT)
Toll Free: 1-877-338-0999
info@championpowerequipment.com
Fax no.: 1-562-236-9429

Technical Service

Mon – Fri 8:30 AM – 5:00 PM (PST/PDT)
Toll Free: 1-877-338-0999
tech@championpowerequipment.com
24/7 Tech Support: 1-562-204-1188

*Except as otherwise stipulated in any of the following enclosed Emission Control System Warranties (when applicable) for the Emission Control System: U.S. Environment Protection Agency (EPA), California Air Resources Board (CARB) and/or Environment and Climate Change Canada (ECCC).

**Champion Power Equipment, Inc. (CPE),
The United States Environment Protection Agency (U.S. EPA.) and the California Air Resources Board (CARB)
Emission Control System Warranty**

Your Champion Power Equipment (CPE) engine complies with both the U.S. EPA and state of California Air Resources Board (CARB) emission regulations.

YOUR WARRANTY RIGHTS AND OBLIGATIONS:

The US EPA, California Air Resources Board, and CPE are pleased to explain the Federal and California Emission Control Systems Warranty on your 2018 small off-road engine (SORE) and engine powered equipment. In California, new, small off-road engines (SORE) and new equipment that use small off-road engines (SORE) must be designed, built and equipped to meet the State's stringent anti smog standards. In the other states, new engines and equipment must be designed, built and equipped, at the time of sale, to meet U.S. EPA regulations for small off-road engines (SORE). CPE warrants the emission control system on your small off-road engine (SORE) and equipment for the period of time listed below, provided there has been no abuse, neglect, unapproved modification, or improper maintenance of your equipment.

Your emission control system may include parts such as the carburetor, fuel-injection system, the ignition system, catalytic converter and fuel lines. Also included may be hoses, belts, connectors and other emission related assemblies. Where a warrantable condition exists, CPE will repair your small off-road engine (SORE) at no cost to you including diagnosis, parts and labor. For engines less than or equal to 80cc, only the fuel tank and fuel line is subject to the evaporative emission control warranty requirements of this section.

MANUFACTURER'S EMISSION CONTROL SYSTEM WARRANTY COVERAGE:

This emission control system is warranted for two years, subject to provisions set forth below. If, during the warranty period, emission related part on your engine is defective in materials or workmanship, the part will be repaired or replaced by CPE.

OWNER WARRANTY RESPONSIBILITIES:

As the small off-road engine (SORE) owner, you are responsible for the performance of the required maintenance listed in your Owner's Manual. CPE recommends that you retain all your receipts covering maintenance on your small off-road engine (SORE), but CPE cannot deny warranty solely for the lack of receipts or for your failure to ensure the performance of all scheduled maintenance.

As the small off-road engine (SORE) owner, you should however be aware that CPE may deny you warranty coverage if your small, off-road engine (SORE) or a part has failed due to abuse, neglect, improper maintenance or unapproved modifications.

You are responsible for presenting your small off-road engine to an Authorized CPE service outlet or alternate service outlet as described in (3)(f.) below, CPE dealer or CPE, Santa Fe Springs, Ca. as soon as a problem exists. The warranty repairs should be completed in a reasonable amount of time, not to exceed 30 days.

If you have any questions regarding your warranty rights and responsibilities, you should contact:

Champion Power Equipment, Inc.
Customer Service
12039 Smith Ave.
Santa Fe Springs, CA 90670
1-877-338-0999
tech@championpowerequipment.com

EMISSION CONTROL SYSTEM WARRANTY

The following are specific provisions relative to your Emission Control System (ECS) Warranty Coverage.

1. APPLICABILITY: This warranty shall apply to 1995 and later model year California small off-road engines (SORE) (for other states, 1997 and later model year engines). The ECS Warranty Period shall begin on the date the new engine or equipment is delivered to its original, end-use purchaser, and shall continue for 24 consecutive months thereafter.

2. GENERAL EMISSIONS WARRANTY COVERAGE

CPE warrants to the original, end-use purchaser of the new engine or equipment and to each subsequent purchaser that each of its small off-road engines (SORE) is:

a. Designed, built and equipped so as to conform to U.S. EPA emissions standards for spark-ignited engines at or below 19 kilowatts and all applicable regulations adopted by the California Air Resources Board and

b. Free from defects in materials and workmanship that cause the failure of a warranted part to be identical in all material respects to the part as described in the engine manufacturer's application for certification for a period of two years.

3. THE WARRANTY ON EMISSION-RELATED PARTS WILL BE INTERPRETED AS FOLLOWS:

a. Any warranted part that is not scheduled for replacement as required maintenance in the Owners Manual shall be warranted for the ECS Warranty Period. If any such part fails during the ECS Warranty Period, it shall be repaired or replaced by CPE according to Subsection "d" below. Any such part repaired or replaced under the ECS Warranty shall be warranted for any remainder of the ECS Warranty Period.

b. Any warranted, emissions-related part which is scheduled only for regular inspection as specified in the Owners Manual shall be warranted for the ECS Warranty Period. A statement in such written instructions to the effect of "repair or replace as necessary", shall not reduce the ECS Warranty Period. Any such part repaired or replaced under the ECS Warranty shall be warranted for the remainder of the ECS Warranty Period.

c. Any warranted, emissions-related part which is scheduled for replacement as required maintenance in the Owner's Manual shall be warranted for the period of time prior to the first scheduled replacement point for that part. If the part fails prior to the first scheduled replacement, the part shall be repaired or replaced by CPE according to Subsection "d" below. Any such emissions-related part repaired or replaced under the ECS Warranty, shall be warranted for the remainder of the ECS Warranty Period prior to the first scheduled replacement point for such emissions-related part.

d. Repair or replacement of any warranted, emissions-related part under this ECS Warranty shall be performed at no charge to the owner at a CPE Authorized Service Outlet.

e. The owner shall not be charged for diagnostic labor which leads to the determination that a part covered by the ECS Warranty is in fact defective, provided that such diagnostic work is performed at a CPE Authorized Service Outlet.

f. CPE shall pay for covered emissions warranty repairs at non-authorized service outlets under the following circumstances:

i. The service is required in a population center with a population over 100,000 according to U.S. Census 2000 without a CPE Authorized Service Outlet AND

ii. The service is required more than 100 miles from a CPE Authorized Service Outlet. The 100 mile limitation does not apply in the following states: Alaska, Arizona, Colorado, Hawaii, Idaho, Montana, Nebraska, Nevada, New Mexico, Oregon, Texas, Utah and Wyoming.

g. CPE shall be liable for damages to other original engine components or approved modifications proximately caused by a failure under warranty of an emission-related part covered by the ECS Warranty.

h. Throughout the ECS Warranty Period, CPE shall maintain a supply of warranted emission-related parts sufficient to meet the expected demand for such emission-related parts.

i. Any CPE Authorized and approved emission-related replacement part may be used in the performance of any ECS Warranty maintenance or repair and will be provided without charge to the owner. Such use shall not reduce CPE's warranty obligation.

j. Unapproved add-on or modified parts may not be used to modify or repair a CPE engine. Such use voids this ECS Warranty and shall be sufficient grounds for disallowing an ECS Warranty claim. CPE shall not be liable hereunder for failures of any warranted parts of a CPE engine caused by the use of such an unapproved add-on or modified part.

EMISSION-RELATED PARTS INCLUDE THE FOLLOWING: (using those portions of the list applicable to the engine)

| Systems covered by this warranty | Parts Description |
|----------------------------------|--|
| Fuel Metering System | Fuel regulator, Carburetor and internal parts |
| Air Induction System | Air cleaner, Intake manifold |
| Ignition System | Spark plug and parts, Magneto ignition system |
| Exhaust System | Exhaust manifold, catalytic converter |
| Miscellaneous Parts | Tubing, Fittings, Seals, Gaskets, and Clamps associated with these listed systems. |
| Evaporative Emissions | Fuel Tank, Fuel Cap, Fuel Line, Fuel Line Fittings, Clamps, Pressure Relief Valves, Control Valves, Control Solenoids, Electronic Controls, Vacuum Control Diaphragms, Control Cables, Control Linkages, Purge Valves, Vapor Hoses, Liquid/Vapor Separator, Carbon Canister, Canister Mounting Brackets, Carburetor Purge Port Connector |

TO OBTAIN WARRANTY SERVICE:

You must take your CPE engine or the product on which it is installed, along with your warranty registration card or other proof of original purchase date, at your expense, to any Champion Power Equipment dealer who is authorized by Champion Power Equipment, Inc. to sell and service that CPE product during his normal business hours. Alternate service locations defined in Section (3)(f.) above must be approved by CPE prior to service. Claims for repair or adjustment found to be caused solely by defects in material or workmanship will not be denied because the engine was not properly maintained and used.

If you have any questions regarding your warranty rights and responsibilities, or to obtain warranty service, please write or call Customer Service at Champion Power Equipment, Inc.

**Champion Power Equipment, Inc.
12039 Smith Ave.
Santa Fe Springs, CA 90670
1-877-338-0999
Attn.: Customer Service
tech@championpowerequipment.com**