

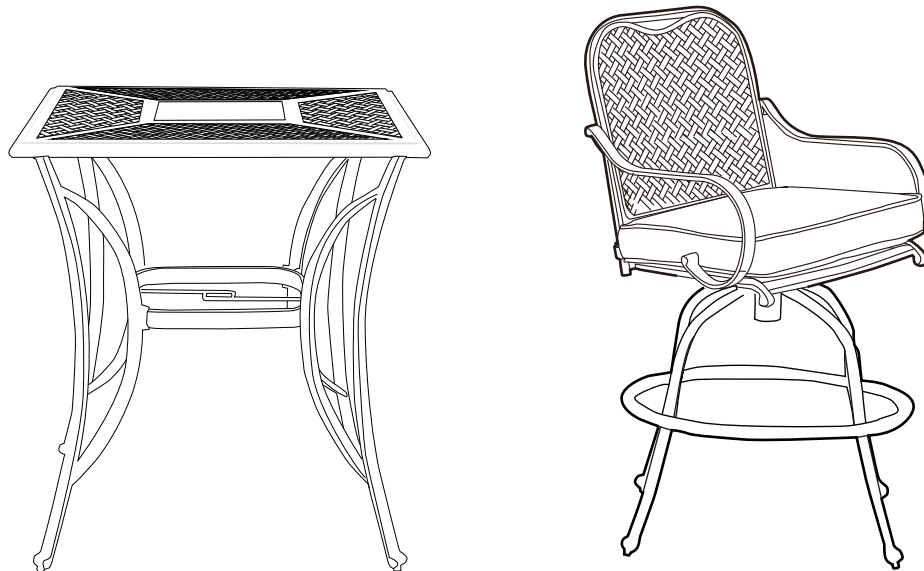

Item#587 624 / 587 626
Model #DY11034-HD-B

USE AND CARE GUIDE

FALL RIVER 3-PIECE HIGH DINING SET



Questions, problems, missing parts? Before returning to the store,
call Hampton Bay Customer Service
8 a.m. - 7 p.m., EST, Monday-Friday
9 a.m. - 6 p.m., EST, Saturday

1-855-HD-HAMPTON

HAMPTONBAY.COM

THANK YOU

We appreciate the trust and confidence you have placed in Hampton Bay through the purchase of this dining set. We strive to continually create quality products designed to enhance your home. Visit us online to see our full line of products available for your home improvement needs. Thank you for choosing Hampton Bay!

Table of Contents

Table of Contents	2	Assembly	6
Safety Information	2	Care and Cleaning	8
Warranty	2		
What is Covered	2		
What is Not Covered	2		
Pre-Assembly	3		
Planning Assembly	3		
Hardware Included	3		
Table Package Contents	4		
Bar Chair Package Contents	5		

Safety Information



WARNING: Do not sit or stand on the table top.



WARNING: Do not place heavy items on the table top.

Warranty

THIS IS A RESIDENTIAL WARRANTY AND NOT APPLY FOR COMMERCIAL USE

2 YEAR FRAME AND FABRIC LIMITED WARRANTY

WHAT IS COVERED

We warrant the frame and fabric to be free of manufacturing defects to the original purchaser for two years.

WHAT IS NOT COVERED

It remains the customer's responsibility for freight and packaging charges to and from our service center.

This warranty does not cover commercial use, hardware, acts of nature, fire, freezing, and abusive use.

In addition, purchased parts are not covered under this warranty. We reserve the right to make substitutions with similar merchandise, if the model in question is no longer in production.

For a copy of our full limited warranty, please contact our customer service team below.

Contact the Customer Service Team at 1-855-HD-HAMPTON or visit www.hamptonbay.com.

Pre-Assembly

PLANNING ASSEMBLY

Please read this entire instruction manual prior to assembly.

Identify all parts packed in the carton against the parts list. Remove all protective materials and place the parts in a non-abrasive surface to avoid scratching.



NOTE: More than one person may be required to complete the assembly of this product.

HARDWARE INCLUDED



NOTE: Tools not shown to actual size.

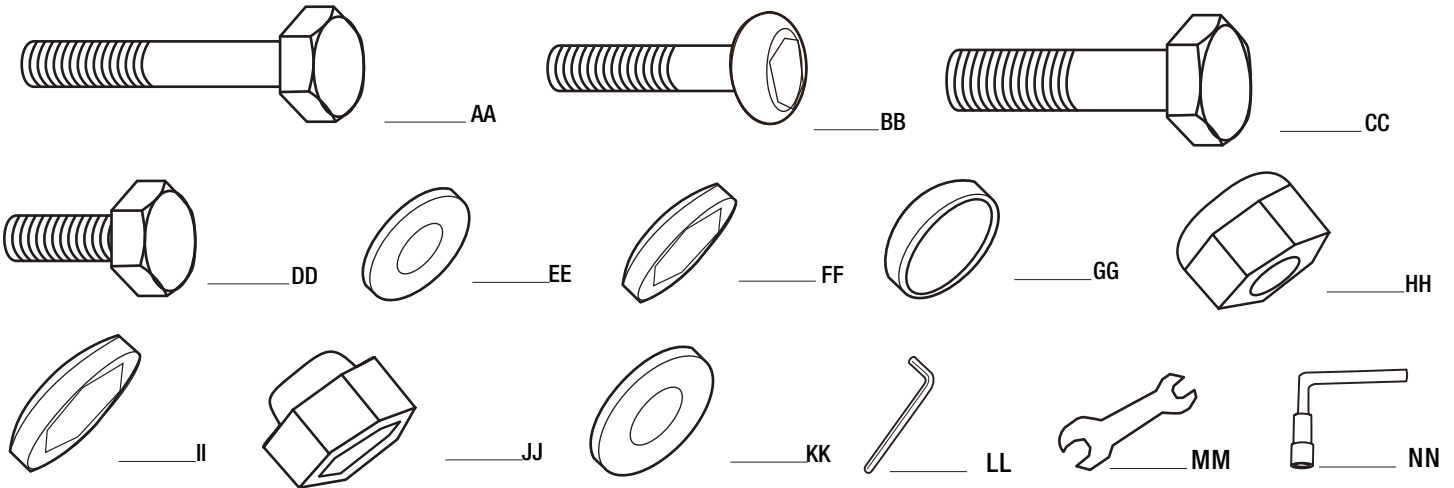

Part	Description	Quantity
AA	M6*35 Hex bolt	8
BB	M6*25 Socket hex bolt	4
CC	M8*30 Hex bolt	8
DD	M6*15 Hex bolt	16
EE	Washer	28
FF	Hex bolt cap	24
GG	M6 Socket hex bolt cap	4
HH	Nut	8
II	M8 Hex bolt cap	8
JJ	Nut cap	8
KK	M8 Washer	16
LL	Hex wrench	1
MM	Wrench	2
NN	Socket wrench	1

Pre-Assembly (continued)

TABLE PACKAGE CONTENTS

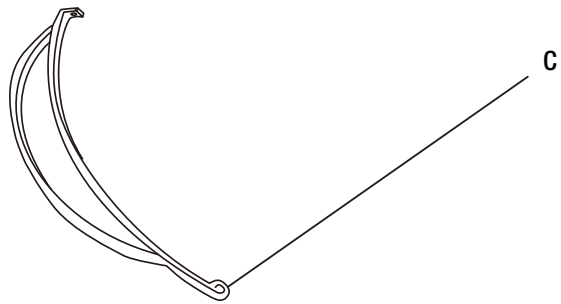
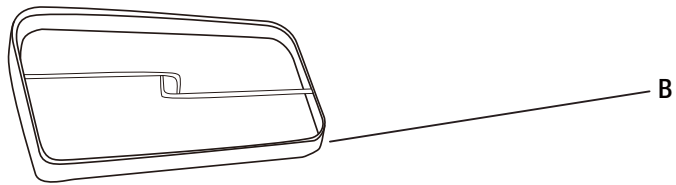
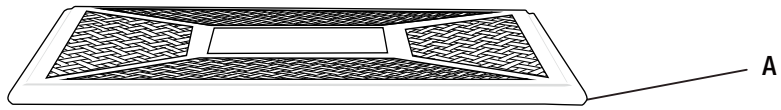

Part	Description	Quantity
A	Table top	1
B	Connector ring	1
C	Table leg	4

Pre-Assembly (continued)

SWIVEL DINING CHAIR PACKAGE CONTENTS

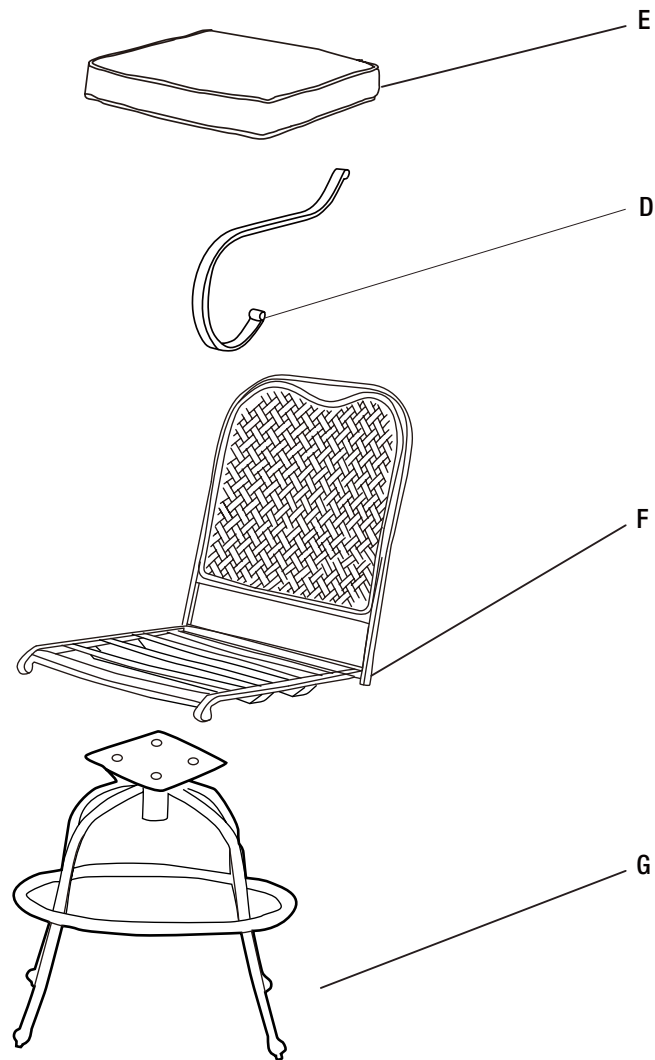

Part	Description	Quantity
D	Arm	4
E	Seat cushion	2
F	Seat frame	2
G	Base	2

Table Assembly

1 Attaching the table legs

- Place the table top (A) on a soft, flat non-abrasive surface. Attach the table legs (C) to the table top (A) using the hex bolts (DD) and washers (EE).



NOTE: Do not fully tighten the bolts.

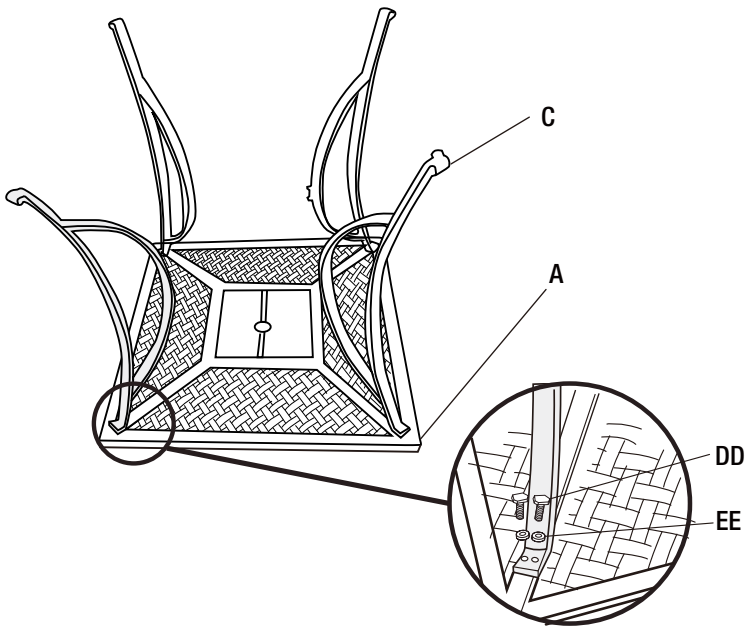

2 Attaching the connector ring

- Attach the connector ring (B) to the table legs (C) using hex bolts (DD) and washers (EE). Tighten all bolts. Then cover the bolt heads with bolt caps (FF).



NOTE: Please ensure all the bolts are assembled correctly and use the socket wrench to tighten.

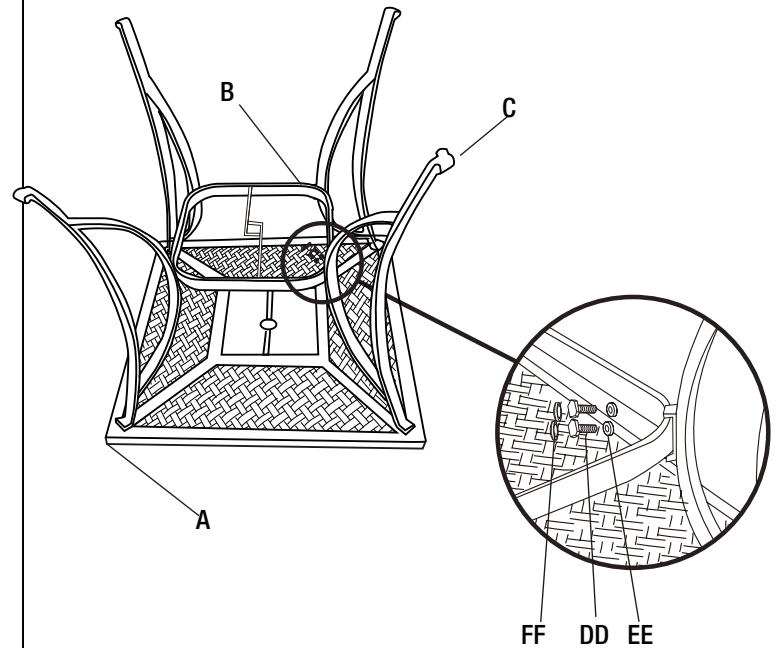

3 Positioning the table

- Turn the table over and set it down on its legs.
- The table is now ready for use.

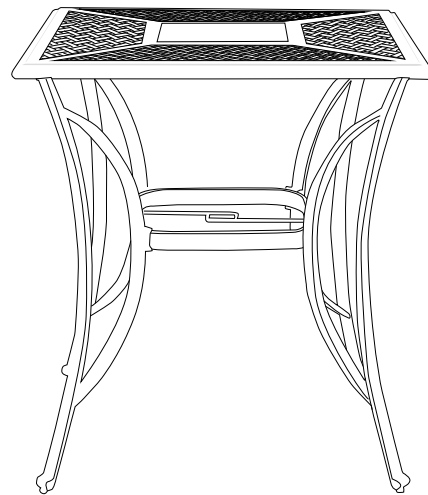

Chair Assembly

1 Attaching the arms

- Place the seat frame (F) on a soft, flat non-abrasive surface.
- Attach the back of the arm (D) to the seat frame (F) using a washer (EE) and socket bolt (BB).
- Attach the front of the arm (D) to the seat frame (F) using washers (EE) and hex bolts (AA).
- Ensure all bolts are aligned and assembled correctly. Tighten all socket hex bolts (BB) with the hex wrench (LL). Attach the socket hex bolt caps (GG).
- Tighten all hex bolts (AA) with the wrench (MM). Attach the hex bolt caps (FF).
- Repeat these instructions to attach the other arms to the seat frames.

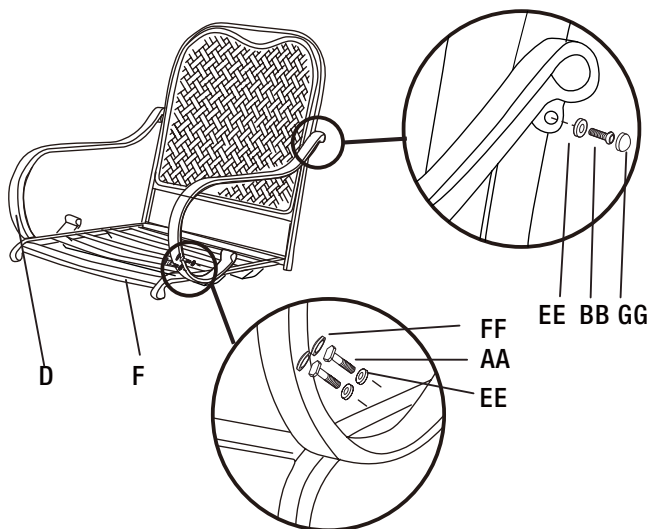

2 Attaching the base

- Attach the base (G) to the seat frame (F) using the washers (KK), hex bolts (CC), and nuts (HH).
- Ensure all bolts are aligned and assembled correctly. Tighten all hex bolts with the wrench (MM). Attach the hex bolt caps (II) and nut caps (JJ).

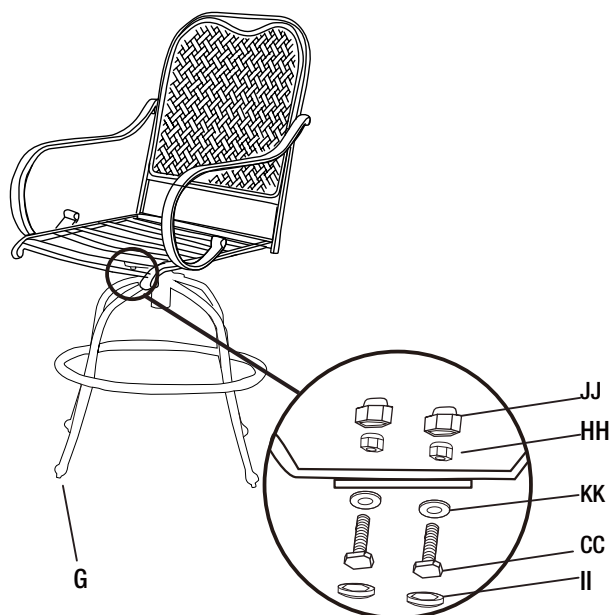

3 Placing the cushions

- Place the seat cushion (E) on the seat.

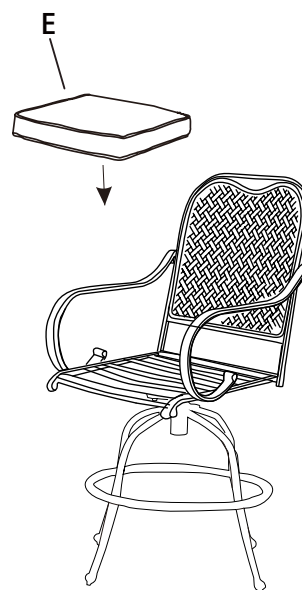

Care and Cleaning

- Do not allow water to build up in the frames. This will cause corrosion and possible freezing damage in cold climates.
- Use a mild soap and water for normal cleaning. Do not use janitorial or alcohol based cleaners. Some cleaners may be marked as natural, but some ingredients may cause discoloration or have an adverse reaction to your finish.
- Rinse with clean water and dry with a soft, absorbent cloth towel.
- Treat frames with a liquid wax for maximum protection against UV rays and/or salty, damp air.



Questions, problems, missing parts? Before returning to the store,
call Hampton Bay Customer Service
8 a.m. - 7 p.m., EST, Monday-Friday
9 a.m. - 6 p.m., EST, Saturday

1-855-HD-HAMPTON

HAMPTONBAY.COM

Retain this manual for future use.