



OZCO BUILDING PRODUCTS

Product & Packaging Specs

6x6 Column Cap (6X6-CAP-LS)

Item #: 56679

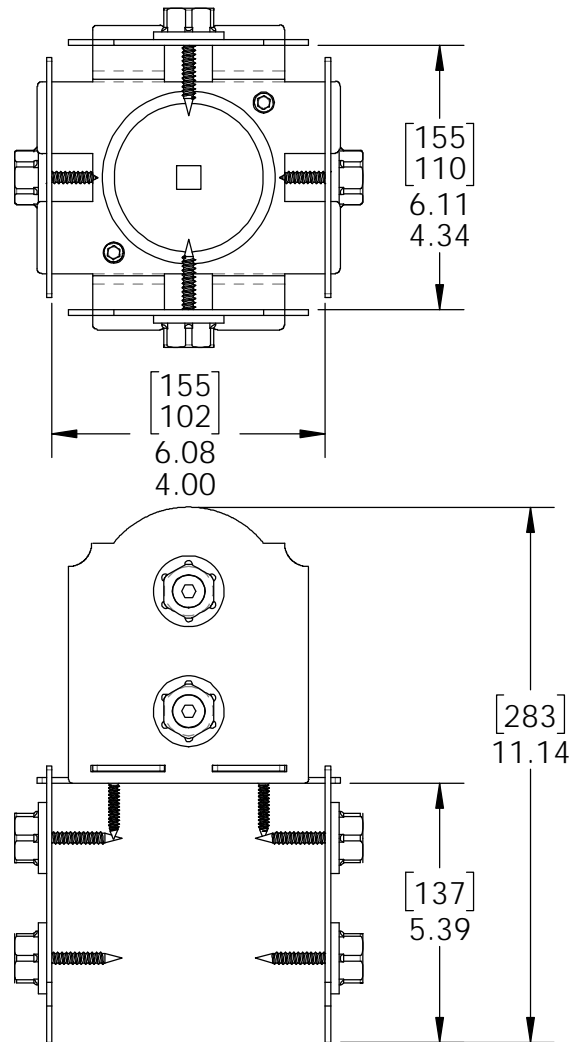

ITEM NO.	QTY.	PART NUMBER	DESCRIPTION
1	4	56679-12	Plate, 6x6 Column Cap Compression LS
2	1	51779-11	Plate, 6x6 Column Cap
3	2	80060	Screw, 1-1/2"x1/4" Black Hex-Head (1-1/2-HX-SCR)
4	0.8	56621	1 1/2" Hex Cap Nut (HCN)
5	0.32	56625	OWT Timber Screw 1-3/4"

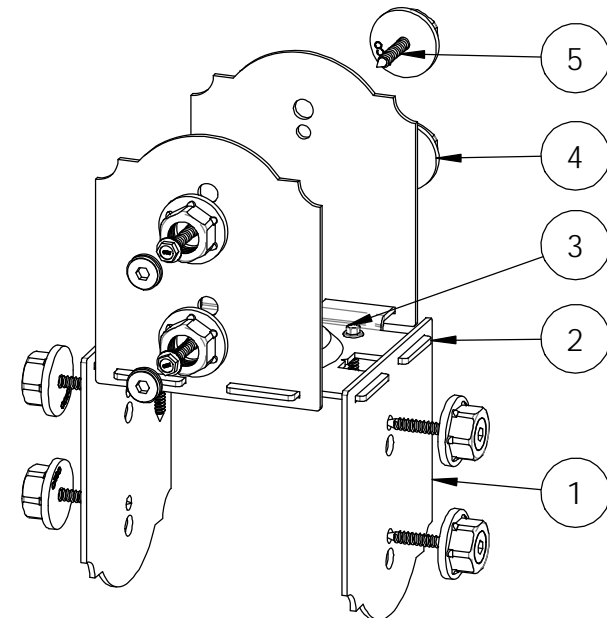

Weight: 4.96 LBS
 Scale: 1:4
 Last updated: 12/15/2017

56679

V2.00 - Installation Instructions, Specifications and Project Plans are effective 12/15/2017 . This information is updated periodically and should not be relied upon after 2 years from 12/15/2017 . Please visit OZCOBP.com to get current information.

Product & Packaging Specs

6x6 Column Cap (6X6-CAP-LS)

Item #: 56679

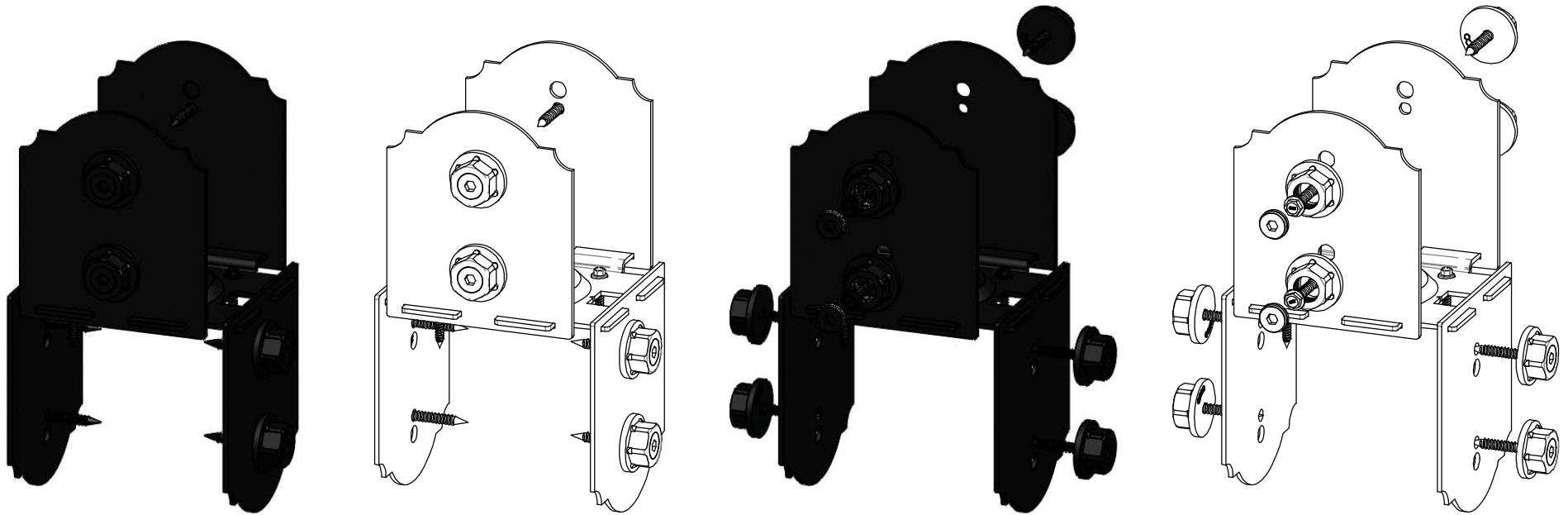

Weight: 4.96 LBS
Scale: 1:1
Last updated: 12/15/2017

56679



Product & Packaging Specs

6x6 Column Cap (6X6-CAP-LS)

Item #: Typical Installation 6x6/2x8's

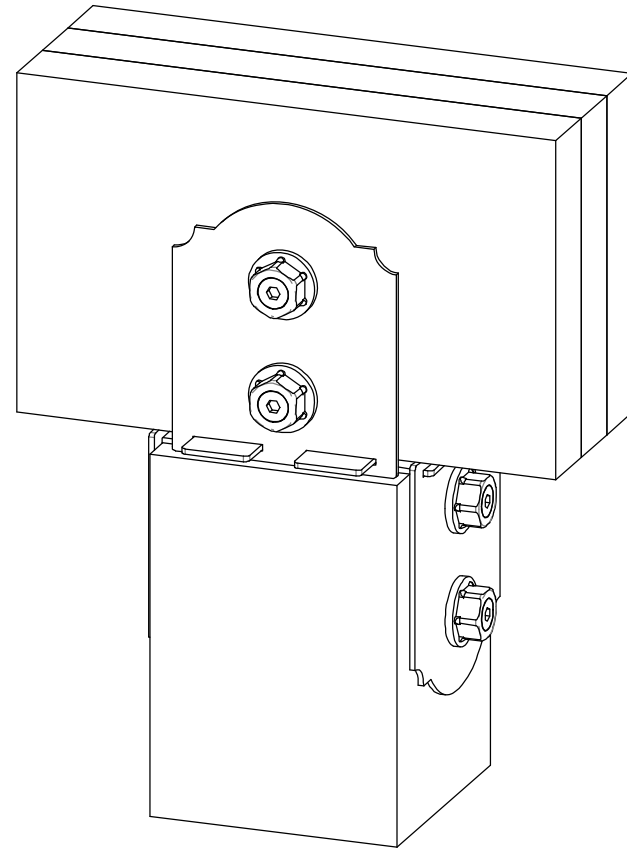
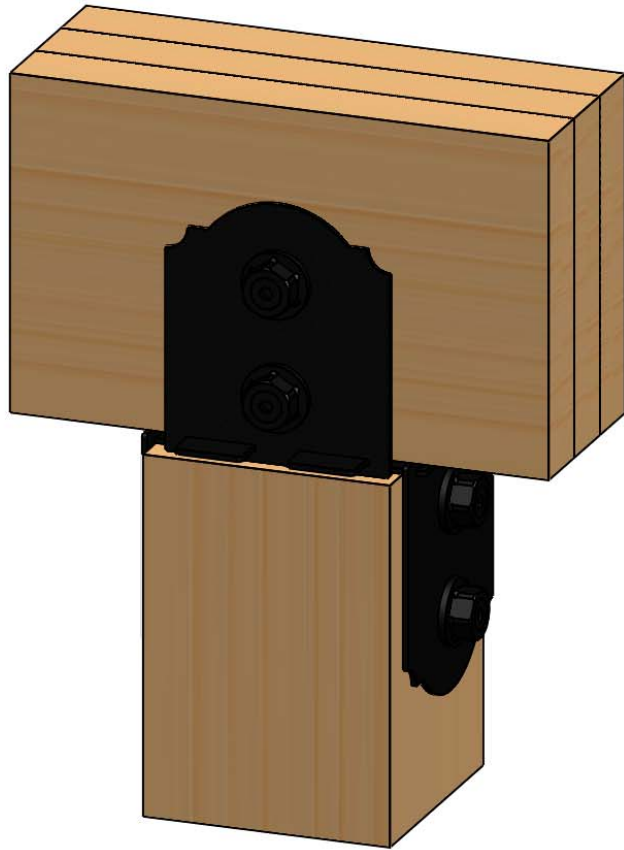

Weight: 28.33 LBS
Scale: 1:1
Last updated: 12/15/2017

56679

V2.00 - Installation Instructions, Specifications and Project Plans are effective 12/15/2017 . This information is updated periodically and should not be relied upon after 2 years from 12/15/2017 . Please visit OZCOBP.com to get current information.



Product & Packaging Specs

6x6 Column Cap (6X6-CAP-LS)

Item #: Typical Installation 6x6/2x8's

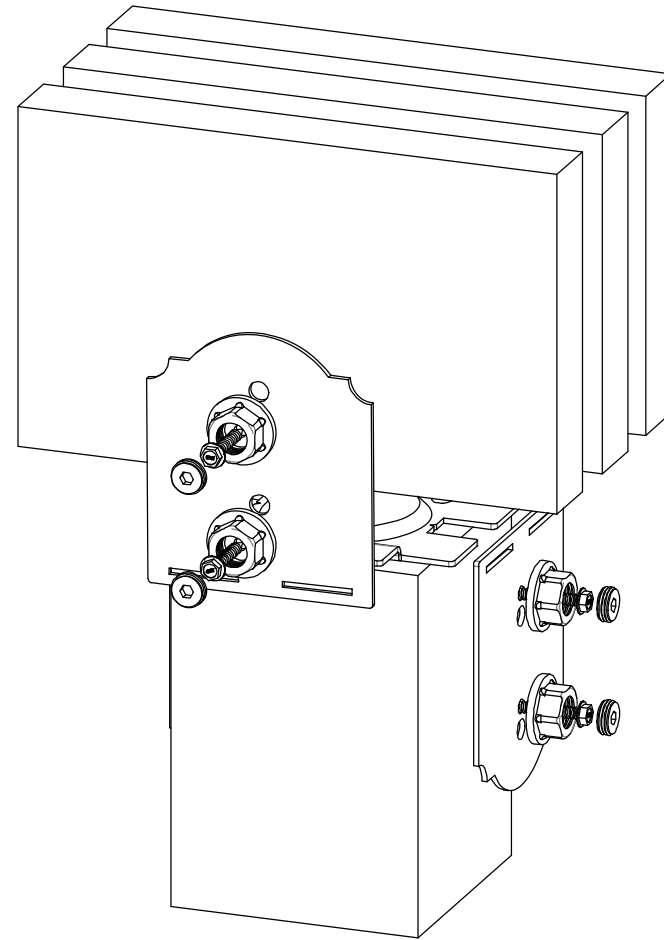
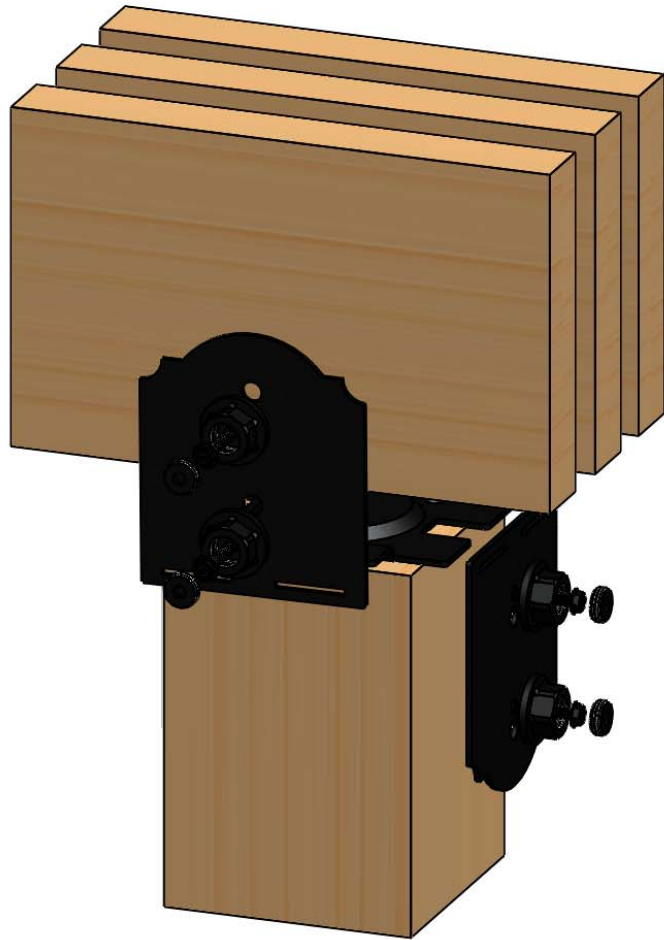

Weight: 28.33 LBS
Scale: 1:1
Last updated: 12/15/2017

56679

V2.00 - Installation Instructions, Specifications and Project Plans are effective 12/15/2017 . This information is updated periodically and should not be relied upon after 2 years from 12/15/2017 . Please visit OZCOBP.com to get current information.



Product & Packaging Specs

6x6 Column Cap (6X6-CAP-LS)

Item #: Typical Installation 6x6/6x6

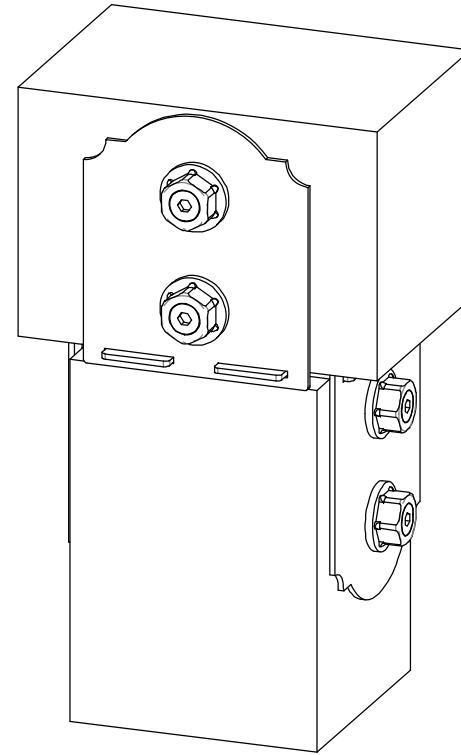
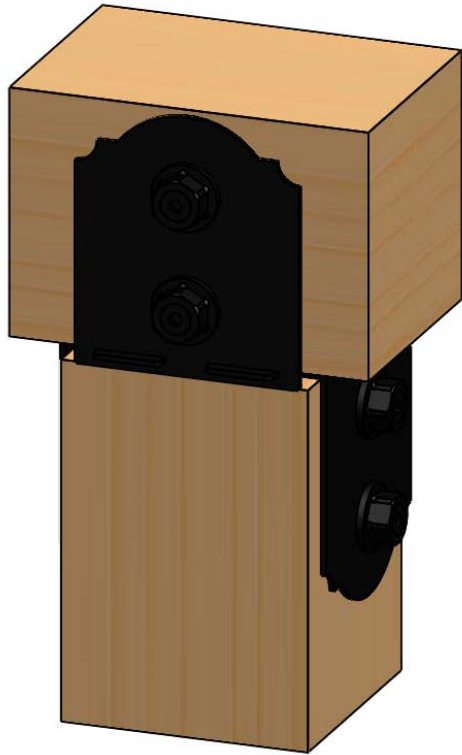

Weight: 22.44 LBS
Scale: 1:1
Last updated: 12/15/2017

56679

V2.00 - Installation Instructions, Specifications and Project Plans are effective 12/15/2017 . This information is updated periodically and should not be relied upon after 2 years from 12/15/2017 . Please visit OZCOBP.com to get current information.

Product & Packaging Specs

6x6 Column Cap (6X6-CAP-LS)

Item #: Typical Installation 6x6/6x6

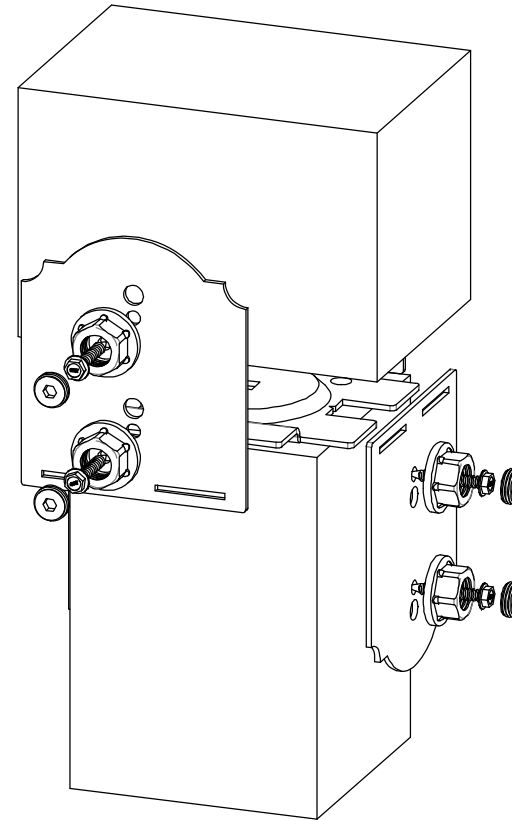
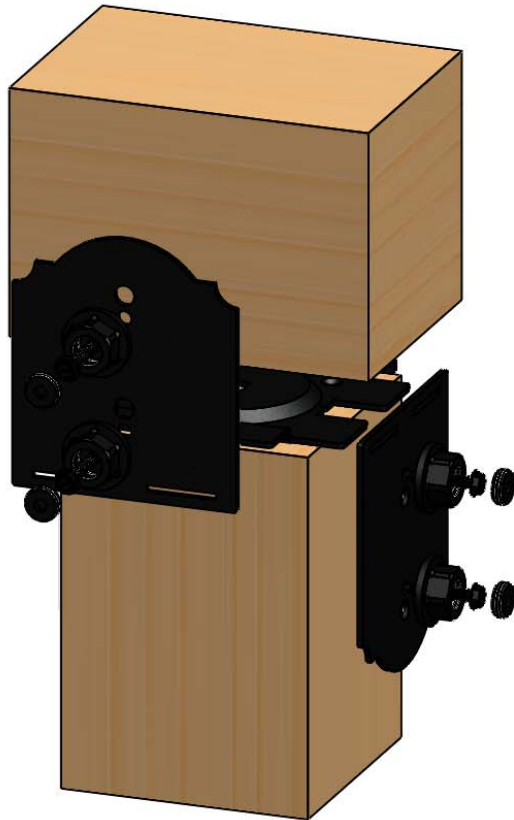

Weight: 22.44 LBS
Scale: 1:1
Last updated: 12/15/2017

56679

Product & Packaging Specs

6x6 Column Cap (6X6-CAP-LS)

Item #: Typical Installation 6x6/6x8

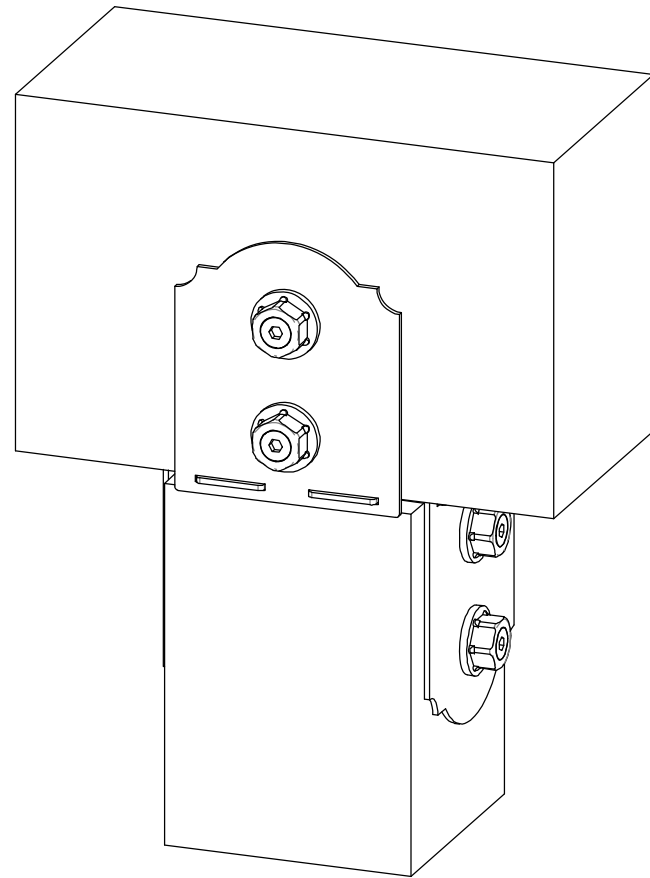
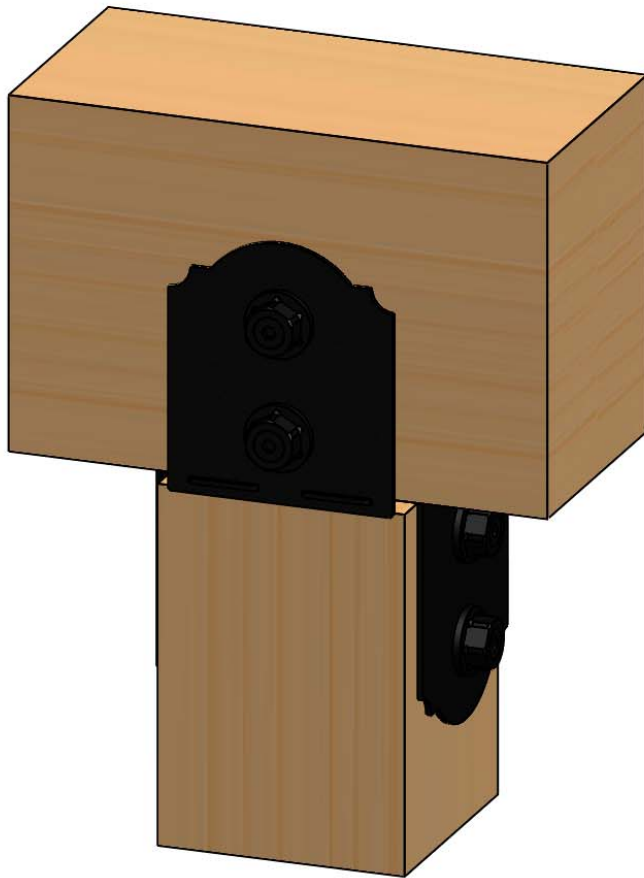

Weight: 22.44 LBS
Scale: 1:1
Last updated: 12/15/2017

56679

Product & Packaging Specs

6x6 Column Cap (6X6-CAP-LS)

Item #: Typical Installation 6x6/6x8

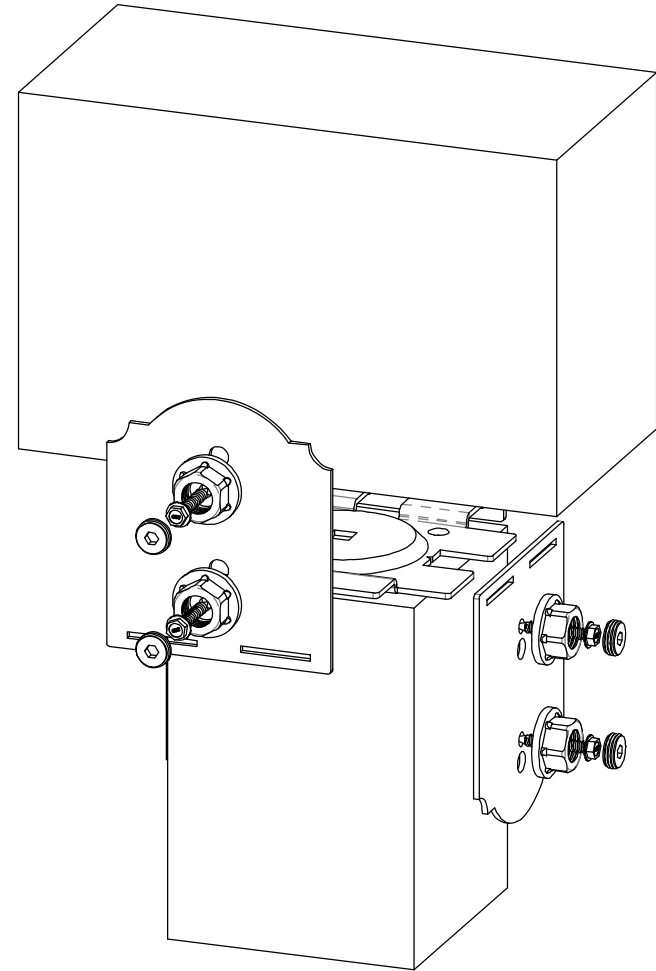

Weight: 22.44 LBS
Scale: 1:1
Last updated: 12/15/2017

56679

Product & Packaging Specs

Box, 56679

Item #: Box

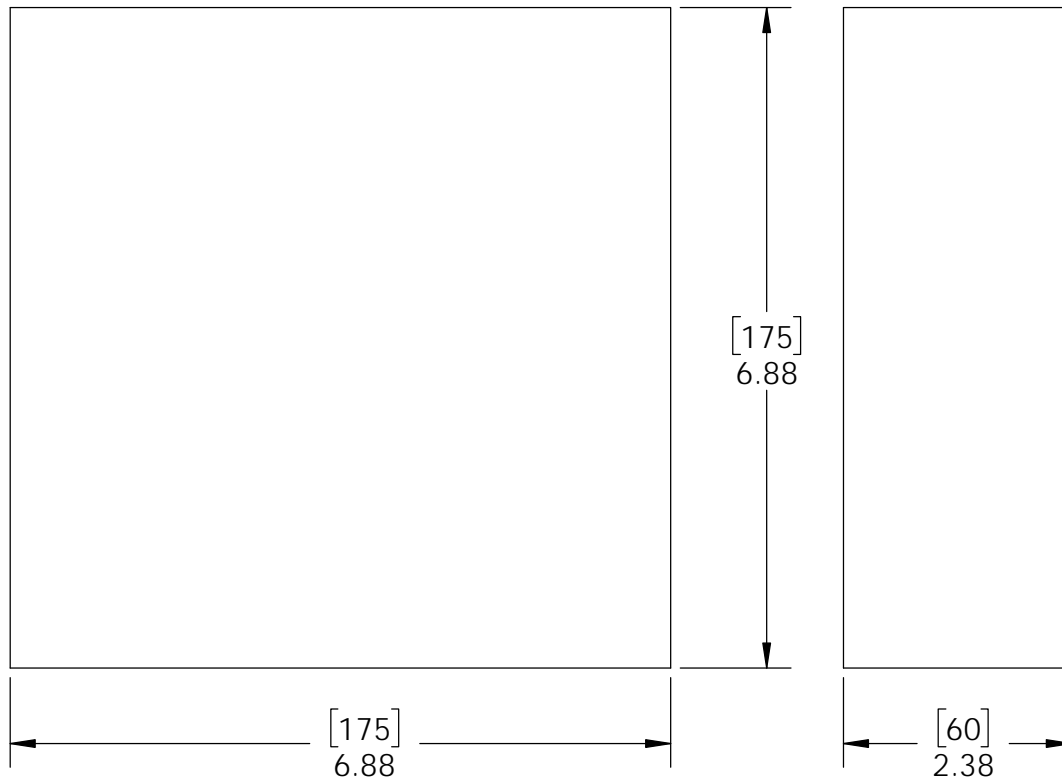

Material: Corrugated Paper
 Finish: See Artwork
 Weight: 0.07 LBS
 Scale: 1:2
 Last updated: 12/15/2017

56679



OZCO BUILDING PRODUCTS

Product & Packaging Specs

56679 Packing

Item #: Box packing

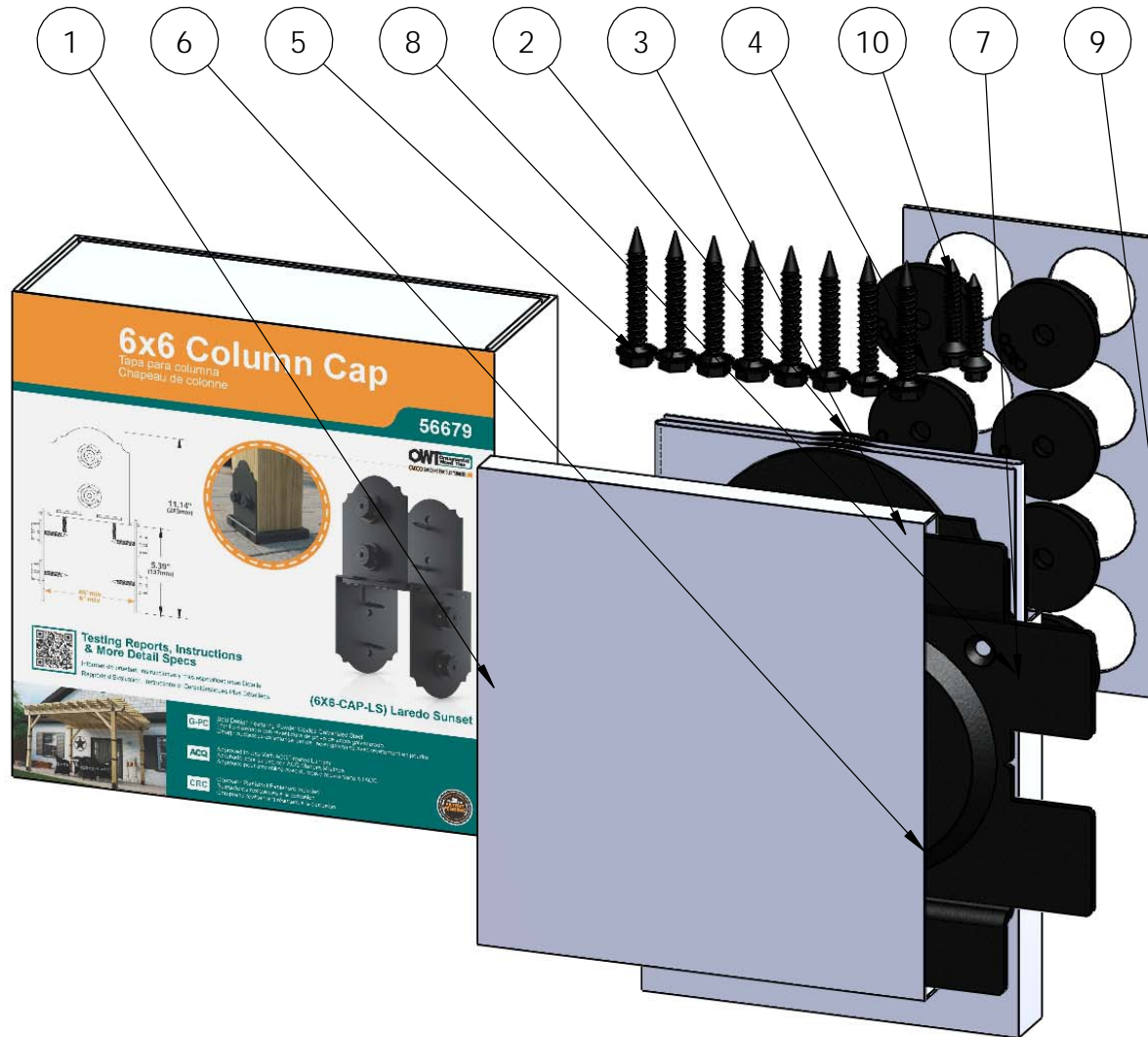

ITEM NO.	QTY.	PART NUMBER	DESCRIPTION
1	1	Box, 56679	Box, 56679
2	4	56679-12	Plate, 6x6 Column Cap Compression LS
3	1	51779-11	Plate, 6x6 Column Cap
4	0.8	56621	1 1/2" Hex Cap Nut (HCN)
5	0.32	56625	OWT Timber Screw 1-3/4"
6	1	Sleeve, 56679	Sleeve, 56679
7	1	Sleeve for Plates, 56679	Sleeve for Plates, 56679
8	1	Insert, 56679	Insert, 56679
9	1	Insert HCN, 56678	Insert HCN, 56678
10	2	80060	Screw, 1-1/2"x1/4" Black Hex-Head (1-1/2-HX-SCR)

Weight: 5.08 LBS
 Scale: 1:2.5
 Last updated: 12/15/2017

56679

additional box packing instructions

- cellophane clear wrap package

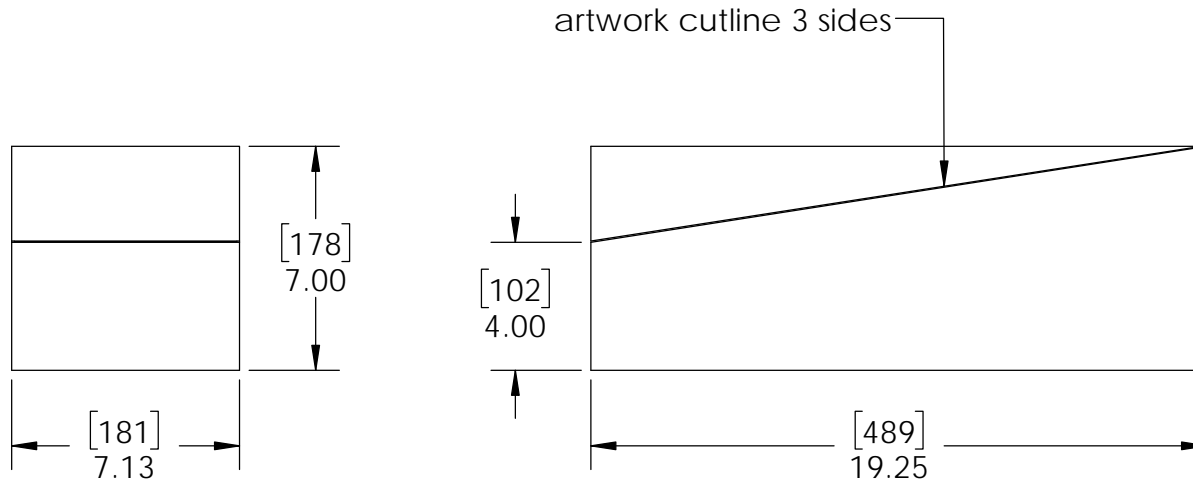

Material: Corrugated Paper
Finish: See artwork
Weight: 0.28 LBS
Scale: 1:6
Last updated: 12/15/2017

56679

Product & Packaging Specs

56679 Packing

Item #: Case packing



Weight: 44 LBS
Scale: 1:2.5
Last updated: 12/15/2017

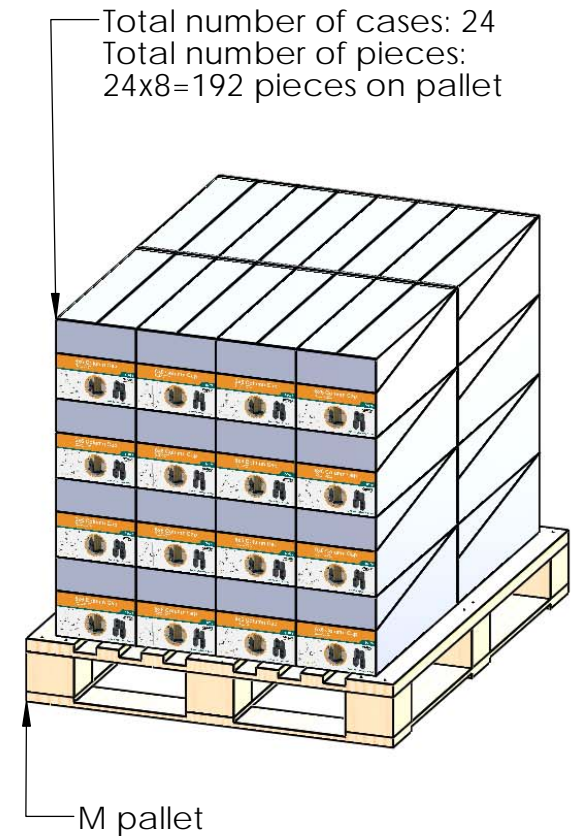
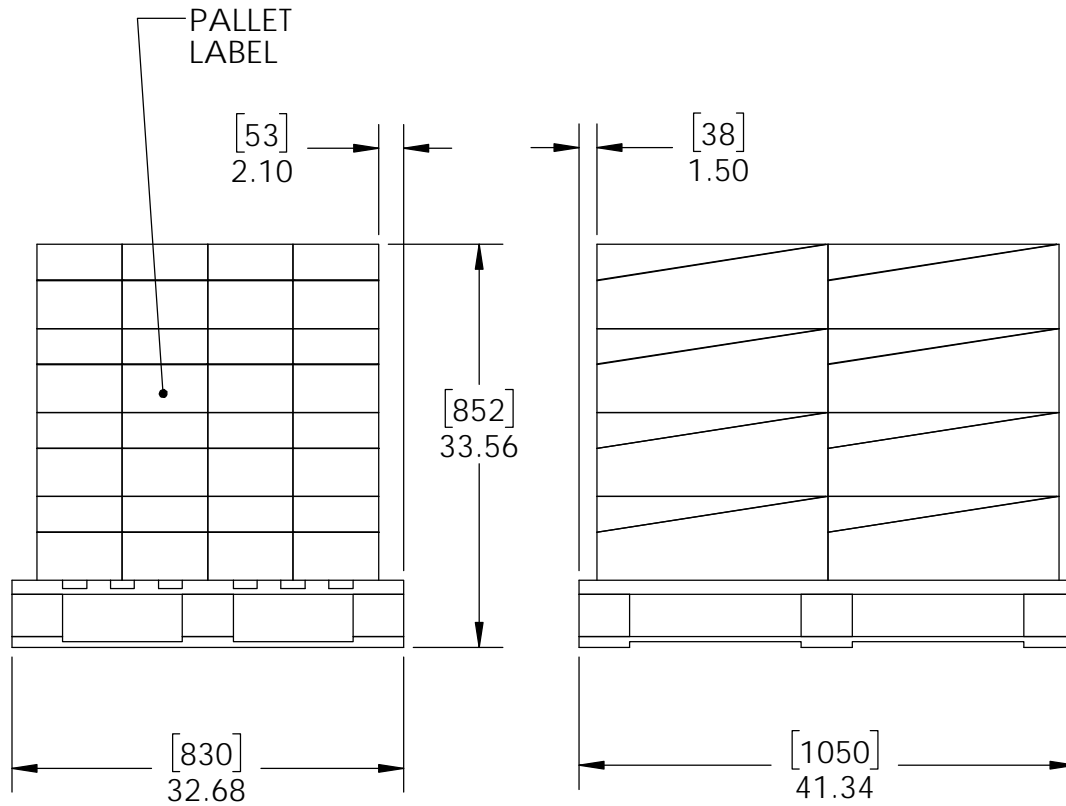

Weight: 1086 LBS
 Scale: 1:16
 Last updated: 12/15/2017

additional pallet packing instructions

- plywood on top layer
- strap to pallet
- clear wrap around boxes

