



Best Barns

Assembly Book

revised February 19, 2016



the Cypress R

10' x 16'

Manufactured by Reynolds Building Systems, Inc.

205 Arlington Drive

Greenville, PA 16125

724-646-3775

This manual is copyrighted. Under the copyright laws, this manual may not be copied, in whole or in part, without consent from Reynolds Building Systems, Inc. © Copyright 2016

IMPORTANT INFORMATION - Read This First

Thank you for your purchase. I want you to be completely satisfied with your building. The 2x4s are imported from Europe because they grade lumber four sides. If you are dissatisfied with lumber you receive we will replace it.

Read the instructions before starting the assembly of the building. If you have any questions about assembling the kit, call 800-245-1577. Business hours (8:00-5:00 ET) Monday thru Friday. After business hours call 724-866-HELP (4357).

The material that is included in our kit is listed on the back page. The optional floor package, if purchased, will be supplied by a local lumber supplier. This will be a separate delivery.

Our kit does not include shingles, the quantity needed is listed on the back page. The siding is primed. You will need to apply a finish coat using latex acrylic paint.

Some of the framing lumber was used in the shipping pallet. Unpack the material from the pallets, then unscrew the top 2x4s. The bit for the screws is packed in the hardware bag. The 2x4s will be used for wall bracing and tie plates.

Most buildings are installed on a wood floor and the siding was designed to extend over the wood flooring. If the foundation is a concrete floor cut the siding flush with the bottom of the wall plate to prevent the concrete from contacting the siding.

Before building, obtain a building permit and check all pertinent building code regulations.

The siding is made in 4x8 sheets with grooves cut into the face, the long edge is beveled so that the siding overlays where they butt.

To identify which edge we want you to use, we will refer to the edge as either the 'LAP' Edge or the Tongue Edge. Nail siding with 8d galv. nails, spaced 12" apart.

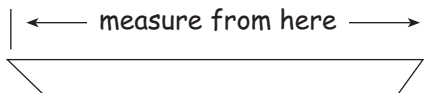
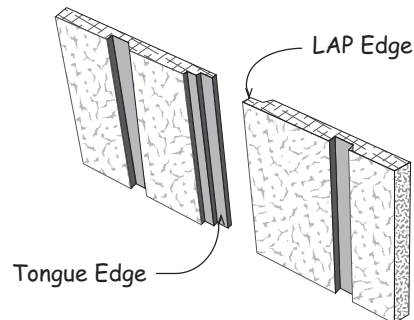

When measurements are given for a board length, it is from the longest side.

Tool List

- | | |
|--|--|
| <input type="checkbox"/> Hammer & Phillips Screwdriver | <input type="checkbox"/> Power Drill/Screwdriver |
| <input type="checkbox"/> Framing Square & Level | <input type="checkbox"/> Measuring Tape |
| <input type="checkbox"/> Hand Saw | <input type="checkbox"/> 2-6' Step Ladders |

Always wear safety glasses when cutting or nailing!

Construction Details for Optional Floor System

Check local building codes in your area, the construction may have to change. For a concrete slab, install sill sealer as a moisture barrier between the concrete and the wall plates. Foam sill sealer can be purchased at home centers in rolls 3-1/2" or wider.

1. Treated lumber is not cut to exact length. Cut (2) two 2x4-16' boards to 16'-0". Layout for 16" on center joist spacing. 'X' marks where floor joist will be placed.

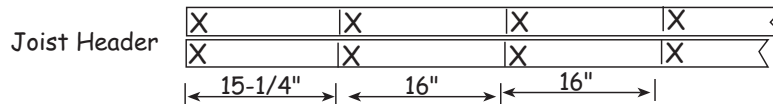

2. Cut the 2x4-10' floor joist to 9'-9". Treated lumber may be thicker than 1-1/2". Take this into account when cutting the length of floor joists. Shorten joist measurements if necessary to obtain 10'-0" building width.
3. Install the floor joist, over the 'X' marks, between the 16' long joist headers. Use 16d galv. deck nails.

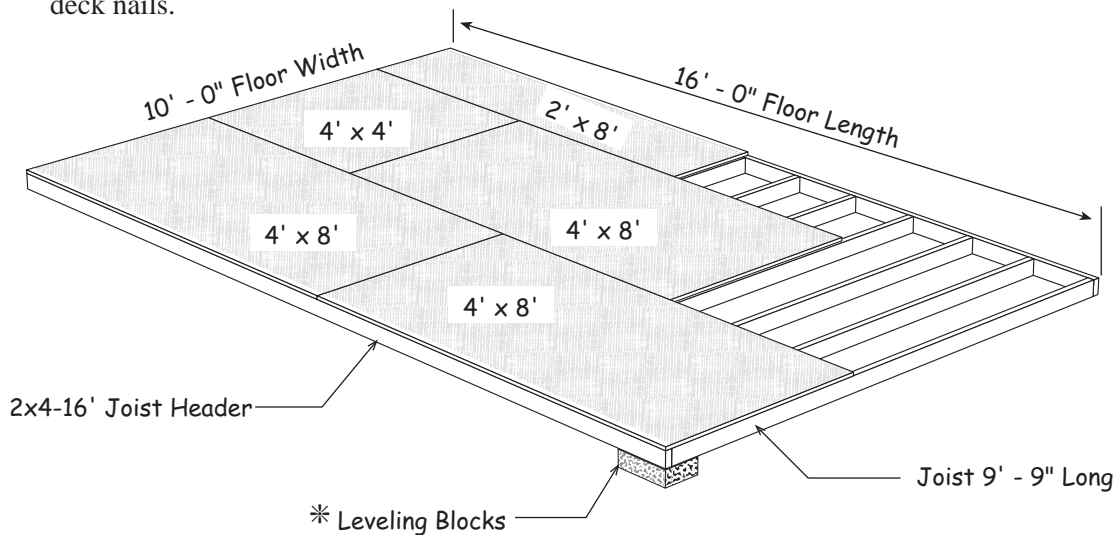

* If necessary use bricks, patio stones or similar material to level or provide additional support to the floor. If your ground has low areas consider adding gravel and or 4x4 treated timbers to rest the floor on. If you use 4x4 timbers you will need (3) three pieces 16' long.

It is important that the floor be level and square. Before nailing the flooring, measure the floor diagonally (corner to corner). Then measure the opposite corners. These measurements will be the same if the floor is square (226-1/2").

Material Description	10' x 16' Floor
2x4 Treated Headers	2 pcs. 16'
2x4 Treated Floor Joist	13 pcs. 10'
Flooring 5/8" 4x8	5 pcs. 4x8
8d Screw Floor Nails	2 lb. 8d
16d Galv. Box Nails	2 lb. 16d

Step 1 Assemble Roof Trusses

Building Tip: Temporarily screw 2x4 blocks to the floor. There are short 2x4s, *that may have an angle on one end*, supplied in the kit for this purpose. This will secure the truss boards in position so all the trusses will be assembled the same. Use the 2-1/2" deck screws packed in the kit.

1. Place (2) two 62" long 2x4 boards with angled ends together as shown below. Hold in place with 2x4 blocks as shown.
2. Secure the tops together with a wood gusset. Nail the gusset to the 2x4s with (14) fourteen 6d common nails. Angle nail slightly so nails do not protrude through the 2x4 boards.
3. Repeat above steps to assemble (6) six more trusses.

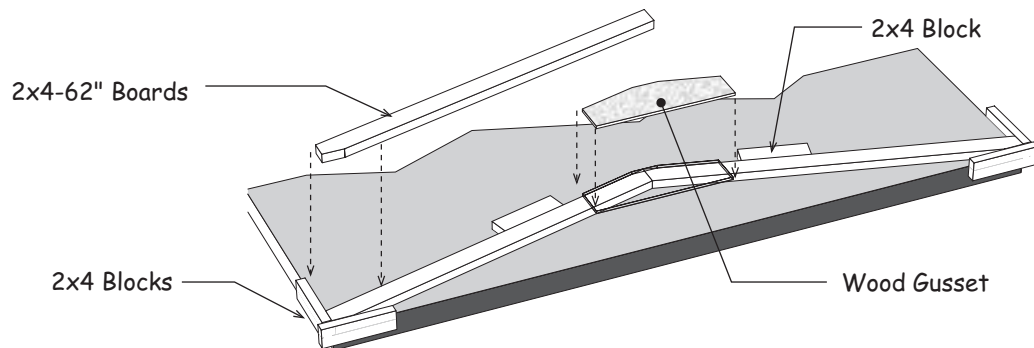

4. **Select (7) seven trusses** and apply wood gussets to the opposite side. (2) two will be used later.
5. Select (5) three trusses that have gussets installed on both sides and install a 1x4-72" long board as shown. Use 6d common nails.
6. Remove 2x4 blocks. Save blocks, some will be used when installing gables.

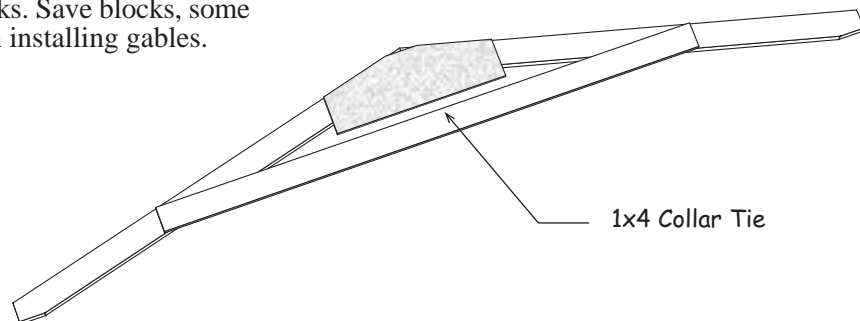

Step 2 Assemble End walls

1. Position (4) four 60" boards together and indicate with 'X' marks, where the wall studs will be located. Mark the ends that will butt together with the letters 'A' and 'B'.

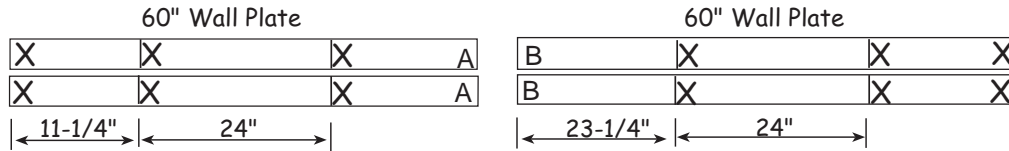

2. Install 72" wall studs between the top and bottom plates. Assemble wall frames with 10d sinkers. Use (2) two nails at end of each wall stud.
3. Nail both wall frames together using 10d sinkers.

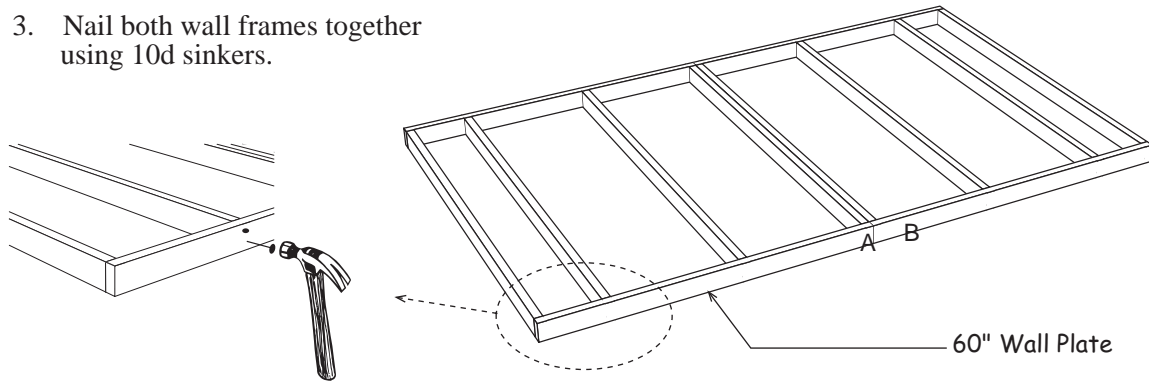

4. Square wall frame, *measure diagonally (corner to corner)*. The measurement should be 141-1/2".
5. Repeat steps 1-4 to assemble next end wall frame.
6. Select a 36-3/4" wide siding panel with a 'tongue' edge. Install this panel with the 'Cut' edge flush with the end of the wall frame. Install siding flush with the 2x4 top plate.
7. Install a full width x 75-3/4" long siding panel next.
8. Install a 36" x 75-3/4" siding panel last.

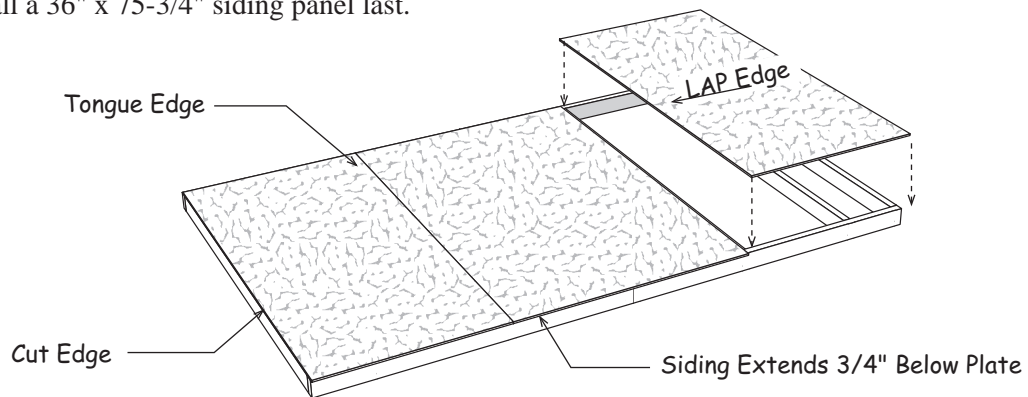

Step 2 Assemble End Walls Continued

8. Install a 60" long 2x4 in the center of the wall panel, at the top. Use 10d sinkers.

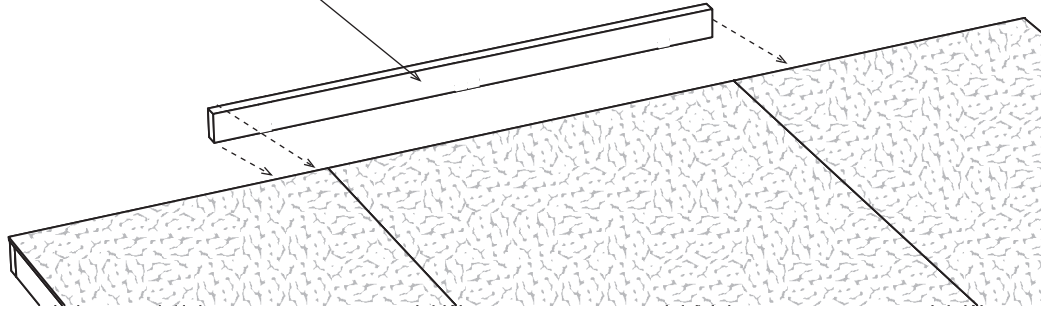

9. Select the other end wall frame.
10. Square wall frame. Select a 12-1/2" wide siding panel with a 'tongue' edge. Install this panel with the 'Cut' edge flush with the end of the wall frame. Install siding flush with the 2x4 top plate.
11. Install (2) two full width x 75-3/4" long siding panel next.
12. Install a 11-3/4" x 75-3/4" siding panel last.

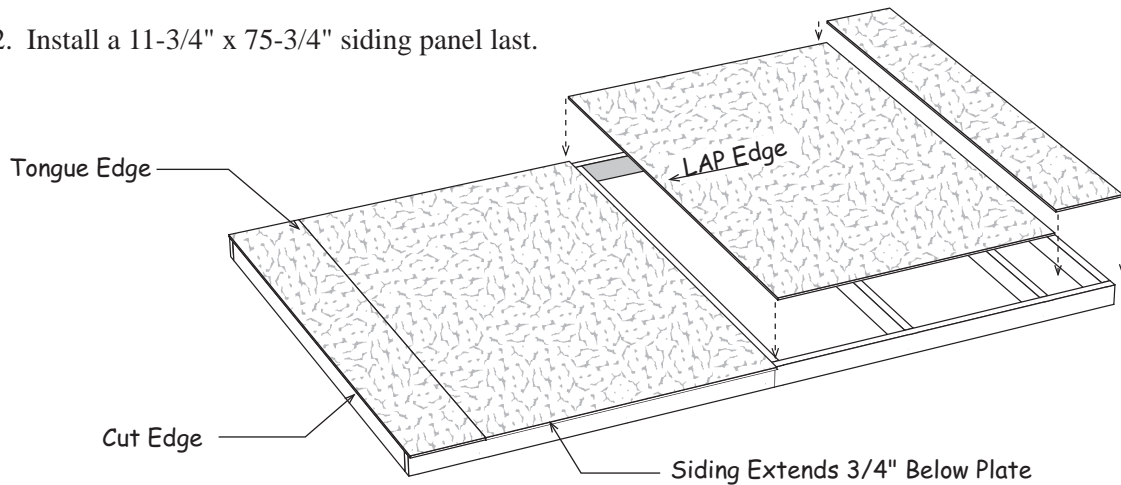

13. Install a 60" long 2x4 in the center of the wall panel.

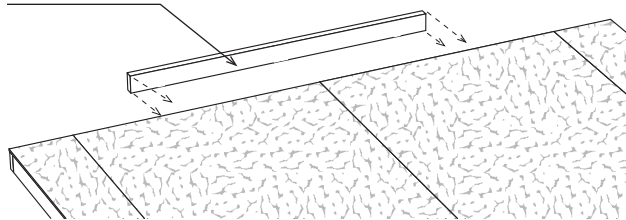

Step 3 Assemble Back Wall

1. Position (2) two 68-1/2" and (2) two 48" long 2x4s together and indicate with 'X' marks, where the wall studs will be located. Mark the ends that will butt together with the letters 'A' and 'B'.

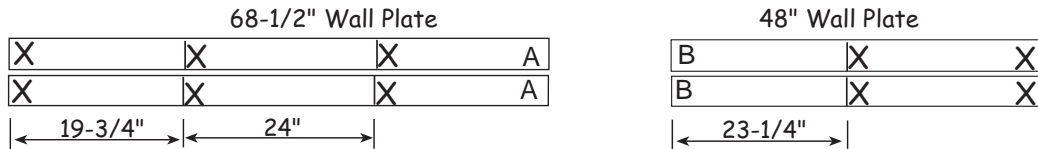

2. Install 72" wall studs between the top and bottom plates. Assemble wall frames with 10d sinkers.
3. Nail both wall frames together.

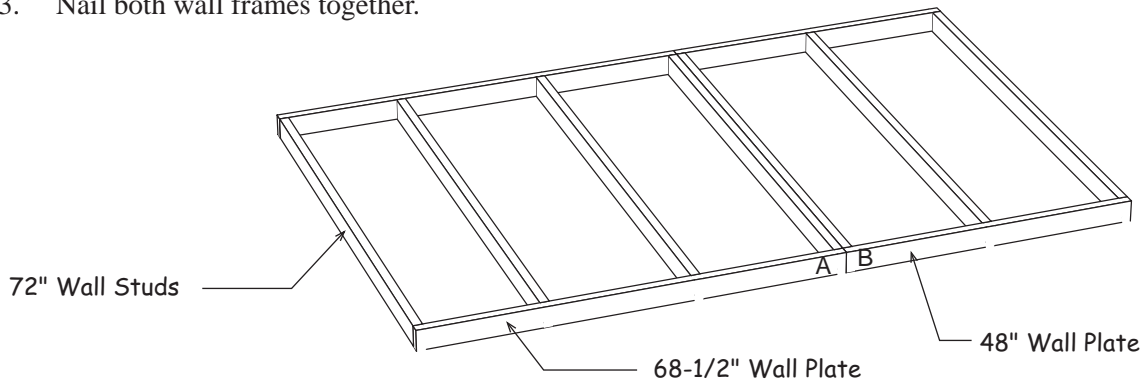

4. Square wall frame. The measurement should be 138-1/2". Install (2) two full width siding panels. Install the first siding panel with the 'LAP' edge extending 3-1/2" past the end of the wall frame. The siding should extend 3/4" below the bottom plate and flush with the top plate.

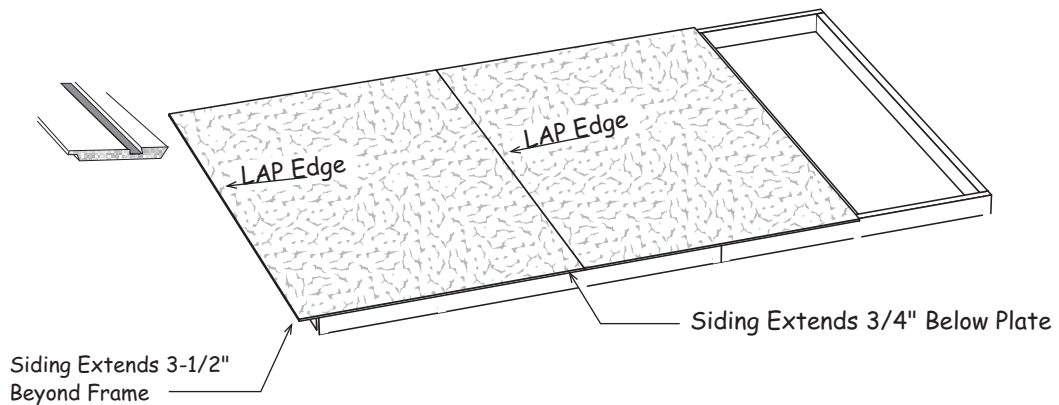

Step 3 Assemble Back Wall Continued

5. Position (2) two 68-1/2" long 2x4s together and indicate with 'X' marks, where the wall studs will be located. Mark the left ends with the letters 'C'.

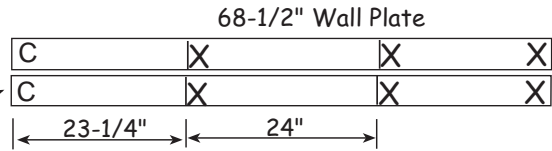

6. Install 72" wall studs between the top and bottom plates.

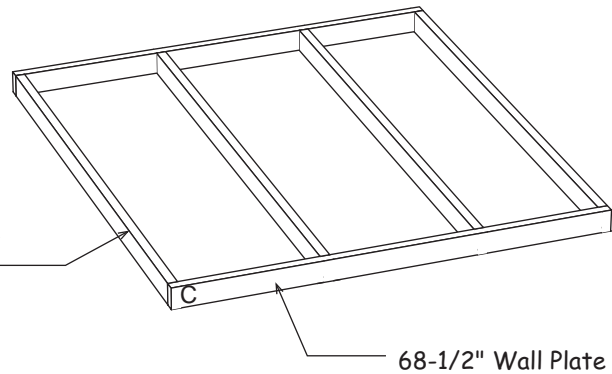

7. Select one of the wall panels from previous step. Nail, with 10d sinkers, the 68-1/2" frame assembled above to the end of the wall panel.
8. Install a full width siding panel. The last siding panel will be installed after the walls are erected on the floor.

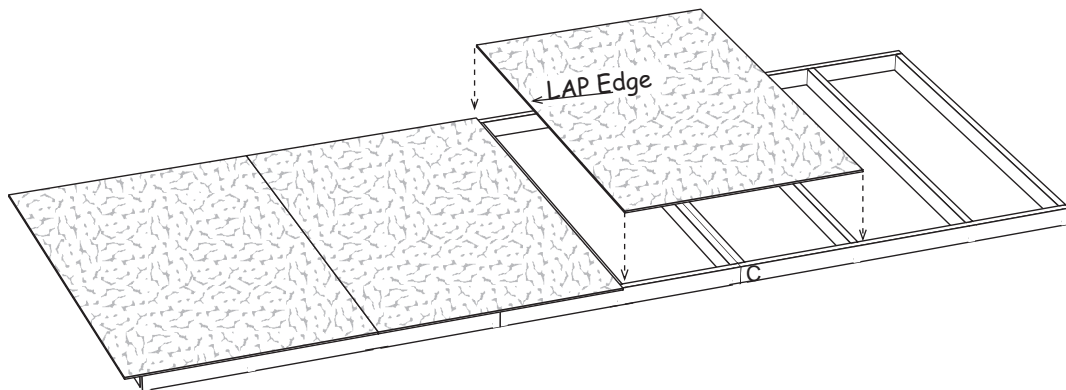

Step 4 Assemble Front Wall Frames

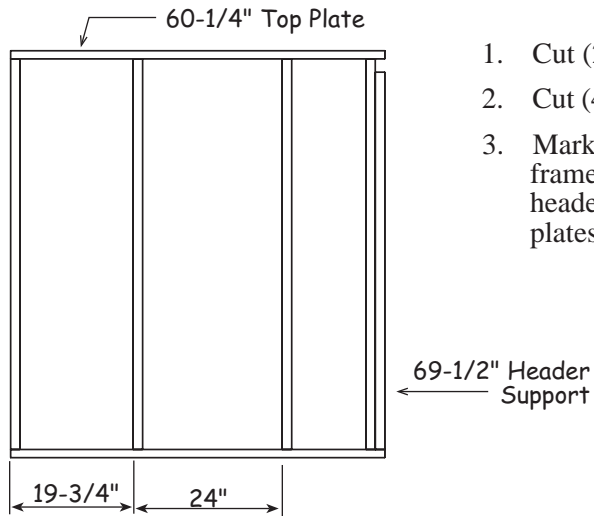

1. Cut (2) two 72" 2x4s to a length of 69-1/2".
2. Cut (4) four 68-1/2" long 2x4 to a length of 60-1/4".
3. Mark spacing as shown on left and assemble a wall frame using (4) four 72" long 2x4s, (1) one 69-1/2" header support and (2) two 60-1/4" top and bottom plates. Repeat to assemble another wall frame.

Step 5 Set Walls

1. Secure the back wall between the end wall panels. Secure panels together at the corners. Use (4) four 10d sinkers per corner. Nail wall panels to the floor. Nail through the bottom plate. Space 10d sinkers 24" apart.

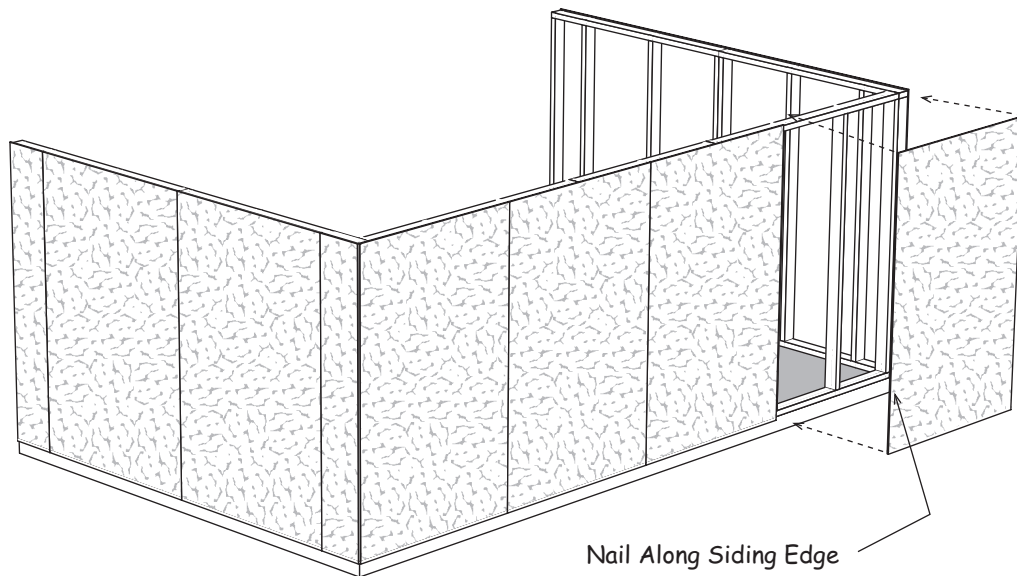

2. Install a 48" x 76" siding panel to the back wall. Use 8d galv. nails. Nail along the adjoining siding panel.

Step 5 Set Walls Continued

3. Install front wall frames between the end walls.
4. Disassemble the shipping pallets and remove the (4) four 2x4s from each pallet. The bit for the screws is in the hardware bag. Use (2) two of the 2x4s to brace the door walls to hold them straight. Save the other 2x4s, they will be used in a later step.

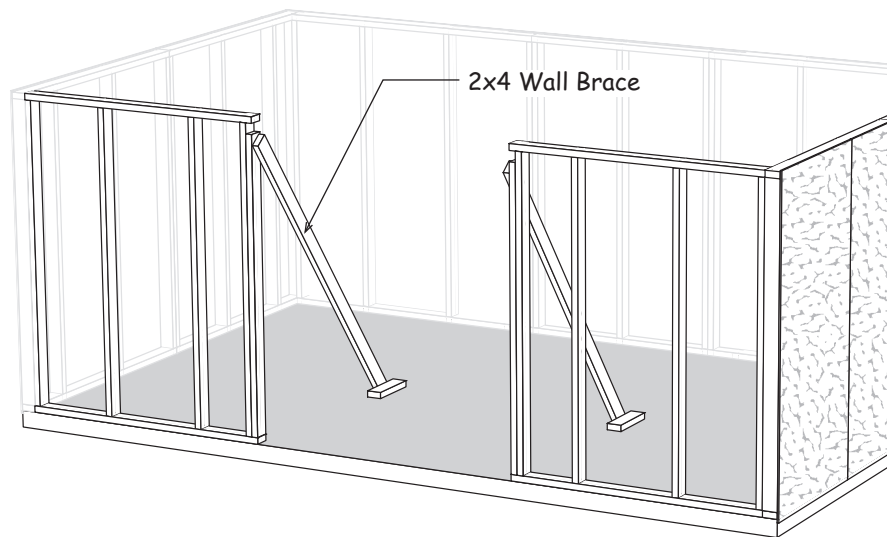

5. Install a 67-1/2" door header between the front wall panels. Secure with 10d sinkers.
6. Cut a 72" long 2x4 to 64-1/2" and install over the door header.

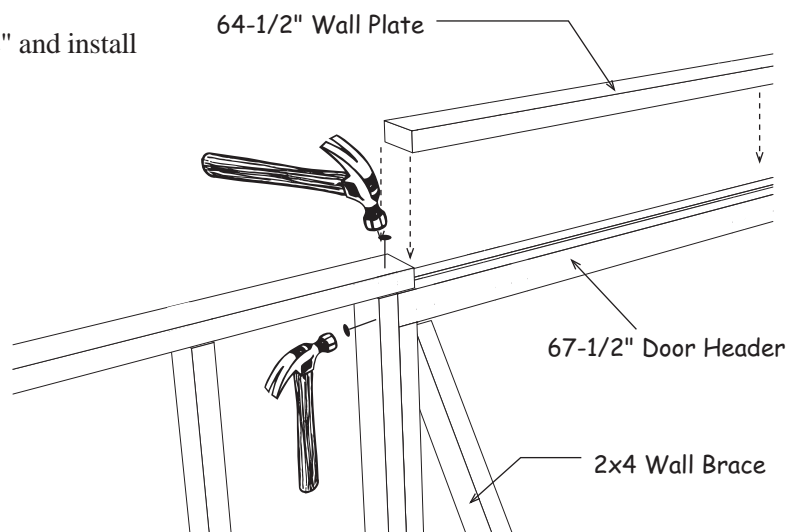

Step 6 Install Siding on Front Wall

1. Select a full width siding panel and install at the front left corner.
2. Install a 15-3/4" siding panel with a 'LAP' edge next.
3. Install (2) two 4-3/4" x 32-1/4" siding panels over the door opening. Trim will cover where the siding panels butt together in the center.

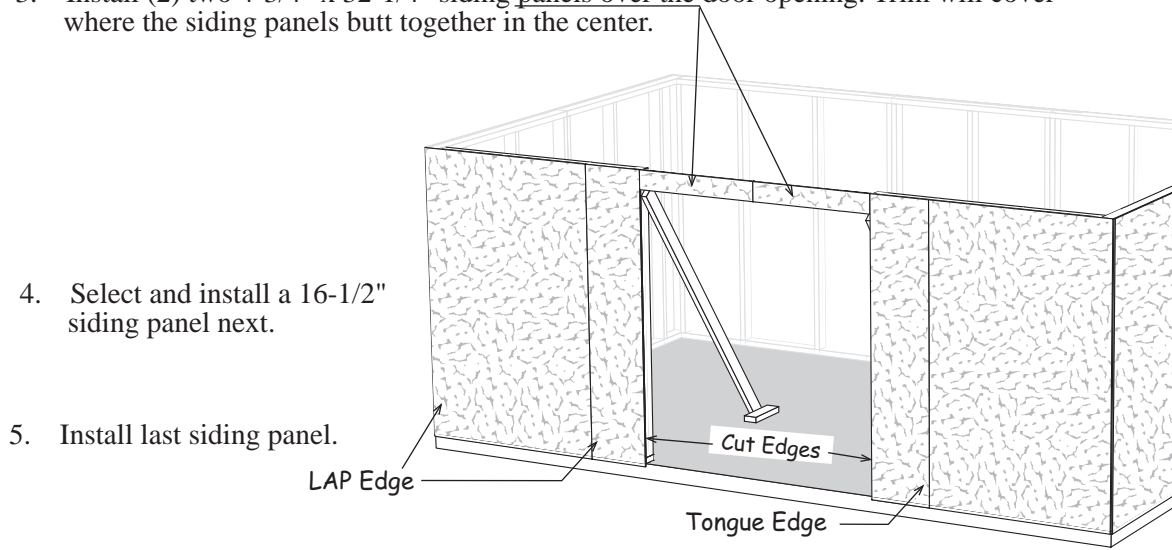

Step 7 Install Tie Plates

1. Cut a 2x4-6' board in half and install one of the boards over the back wall. Install the 2x4 flush with the 2x4 wall plate on the end wall.
2. Install a 48" long 2x4 and then a 72" long 2x4.
3. Finish by installing a 36" long 2x4.
4. Repeat to install tie plates on the front wall.

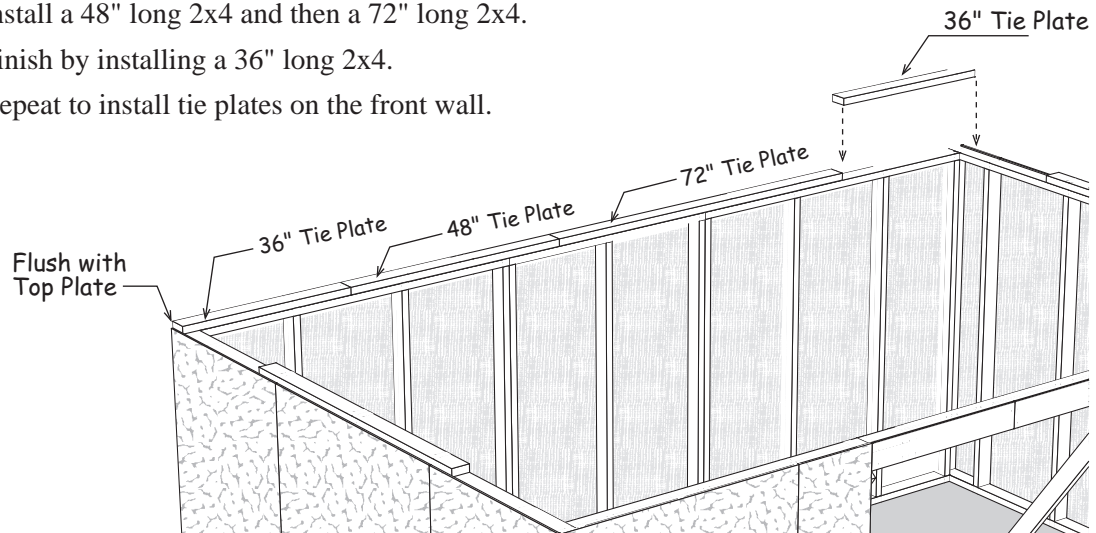

Step 7 Install Tie Plates Continued

5. Cut (4) four 26-1/2" long 2x4s from (2) two 60" long 2x4 boards.
6. Install the 26-1/2" boards on the both end walls, see below.

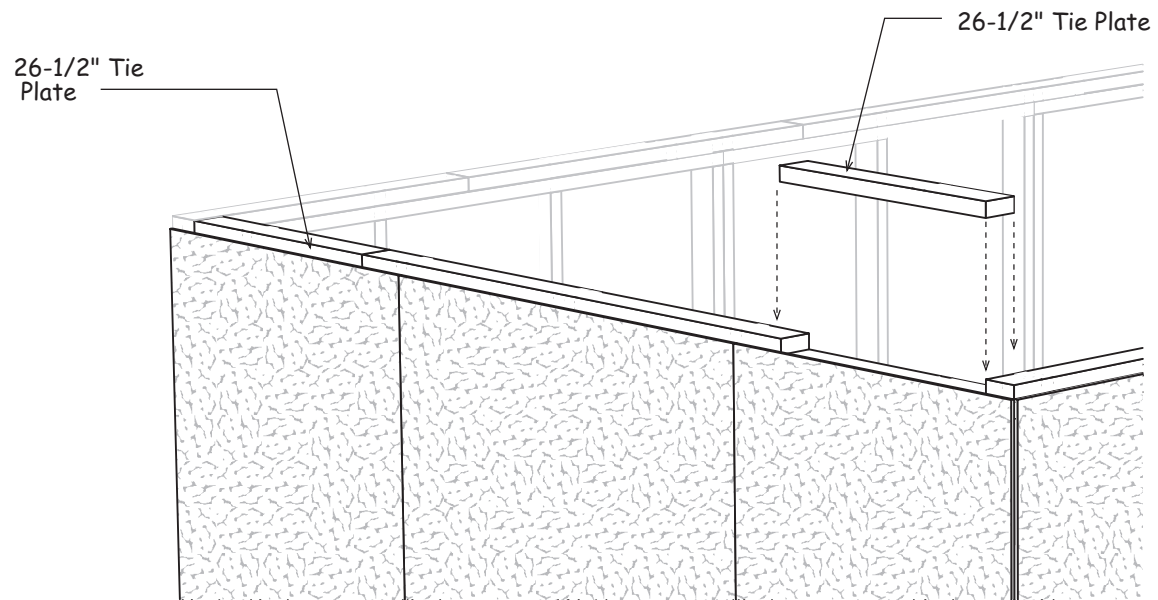

Step 8 Install Roof Gable

1. Select a truss with a gusset installed on one side. Position this truss with the gusset facing towards the inside of the building.
2. Install a 2x4 block to the sidewall, secure the truss to the 2x4 block.
3. Install a 2x4 block to the opposite corner and secure the truss.

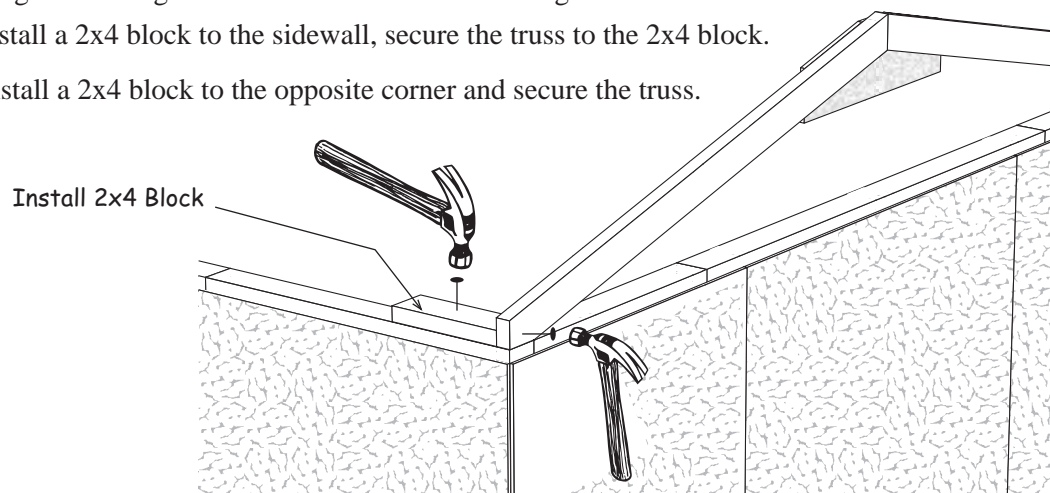

Step 9 Install 'Z' Flashing

Install (2) two 60" pieces of 'Z' flashing across the top of the siding on the end wall siding. Secure in place using 6d galv. nails spaced 12" apart. The ends will be covered by corner trim.

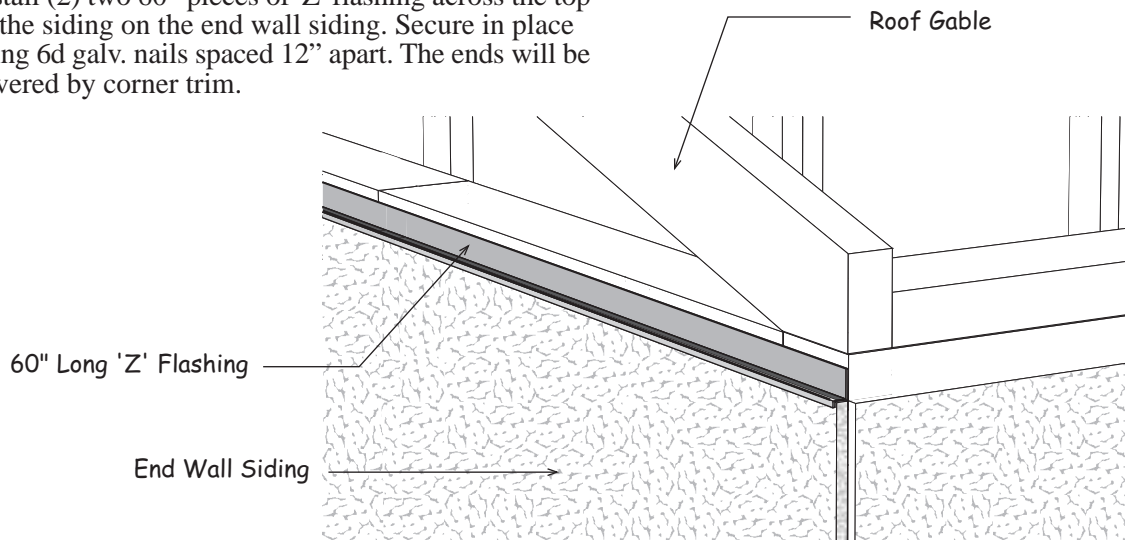

Step 10 Install Roof Gable Siding

1. Install gable siding on the roof gable using 6d galv. nails along the top of the gable frames. Use 8d galv. across the bottom. The gable siding will extend 1/2" above the 2x4 frame to receive the roof sheathing installed later.
2. Repeat **Steps 8 thru 10** to install the opposite gable.

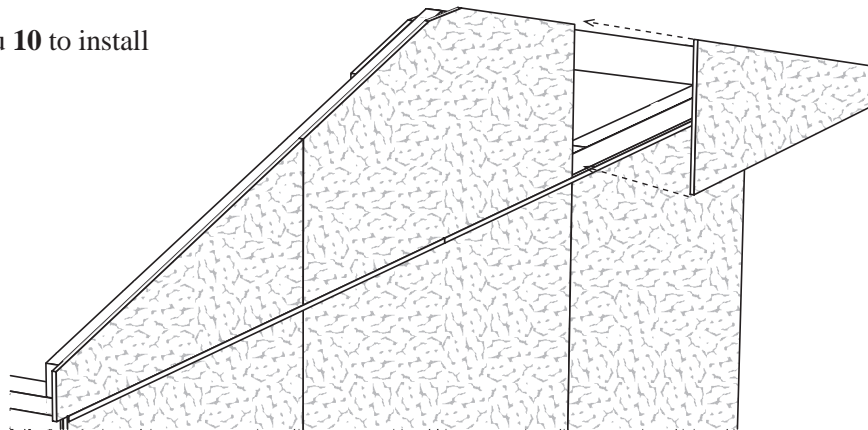

Step 11 Install 2x4 Truss Headers

1. Place a 72" long 2x4 on top of the siding on the front wall. It will butt against the siding on the roof gable. Nail this 2x4 to the 2x4 tie plate with 10d sinkers.
2. Install a 48" 2x4 next.
3. Gather a 2x4 removed from the pallet. Cut to fit and install next to the 2x4 installed above.
4. Repeat to install 2x4 on the back wall.

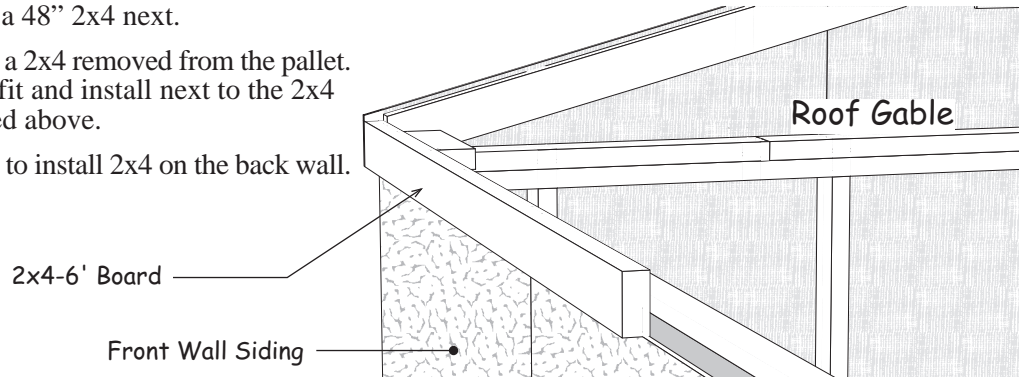

Step 12 Install Trusses

 **Install trusses with a collar tie in the center of the building.**

1. Install trusses over the sidewalls. Install the first truss (without a collar tie) with a 21-3/4" space between the 2x4 face of the rear gable and the back of 2x4 truss. Secure the trusses using 2-1/2" screws and 10d sinkers, See Detail 'A' on next page.
2. Install the remaining trusses measuring 24" from back to back of each truss. Last truss will not have a collar tie.

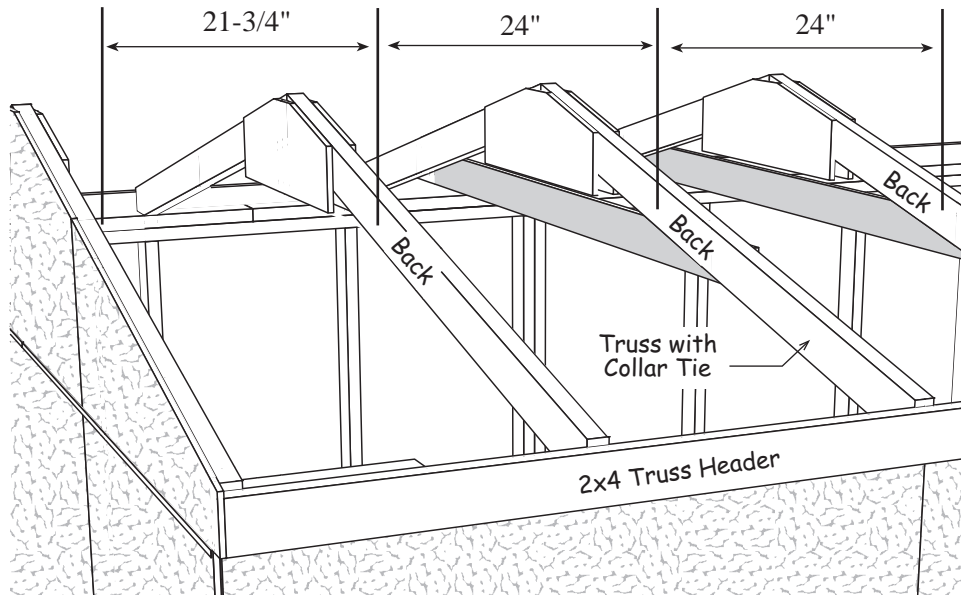

Step 12 Install Trusses Continued

Toe nail truss into 2x4 tie plate using 10d sinkers. Using a 2-1/2" screw, secure truss to 2x4 Truss Header installed in Step 11.

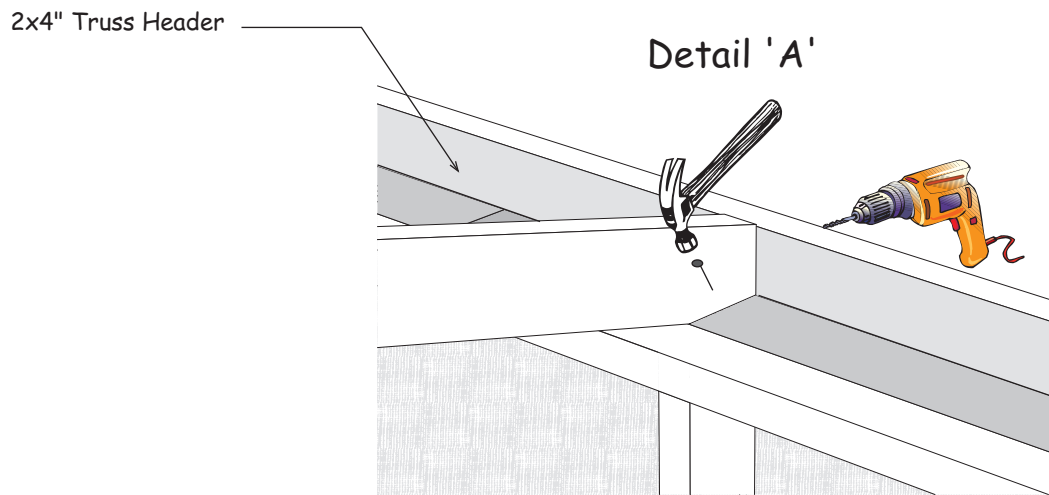

Step 13 Install 1x4 Fascia

1. Install 72" long 1x4 fascia trim over the 2x4 Truss Headers that were installed in **Step 11**. Install 1x4 trim boards flush with the bottom of the 2x4 and siding on the gable.
2. Install a 48" long 1x4 next.
3. Cut a 74" long 1x4 to length and install flush with the siding on the gable.
4. Repeat to install 1x4 fascia on the opposite wall.

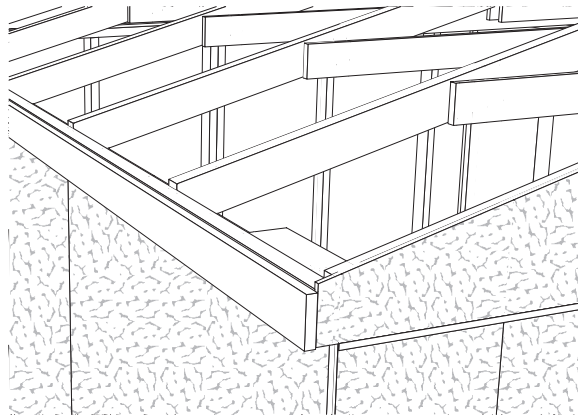

Step 14 Install Roof Sheathing

-  Install roof sheathing with 7d sinkers, space nails 12" apart. When installing sheathing across the top, insert a plyclip into the roof sheathing between each truss. The top row of sheathing will be about 1" below the ridge to allow for optional ridge venting. See detail below.

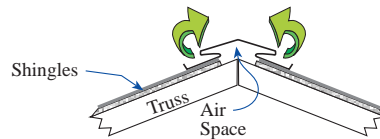

Optional ridge vent provides ideal ventilation.

1. Install the first 4x6 roof sheathing panel against the back of the siding. Note: Using a straight edge install the top edge of the roof sheathing flush with the face of the 1x4 fascia. See Detail 'B'.
2. Install a 15" x 48" sheathing panel at the top.

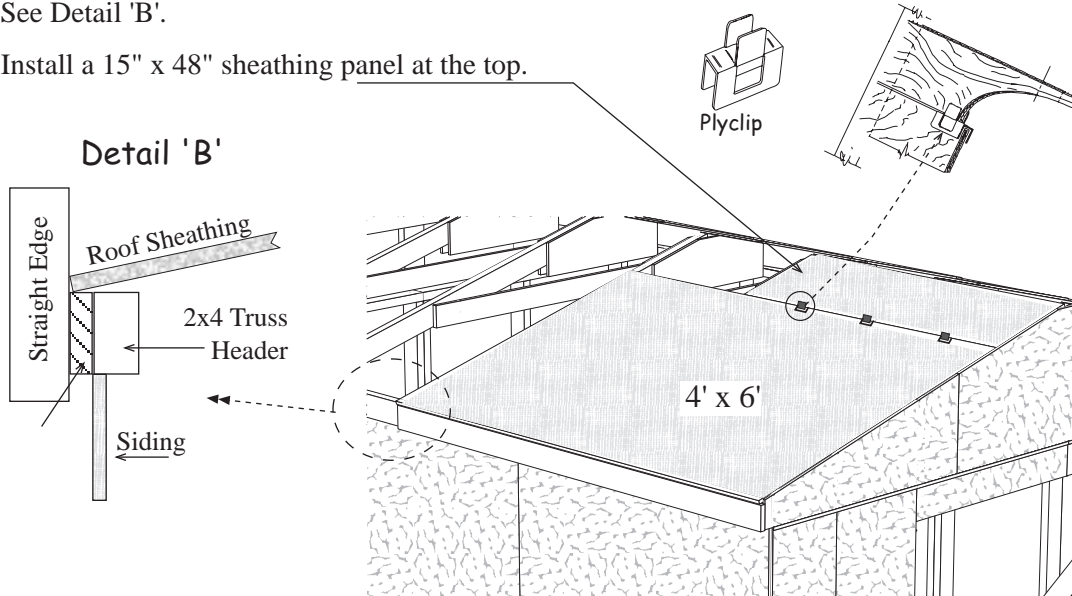

Install roof sheathing on each side of the building per pattern below.

Roof Ridge

15" x 48"	15" x 48"	15" x 48"	15" x 48"
48" x 48"	48" x 72"	48" x 72"	

Step 15 Install Trim

1. Install 64-1/4" long 1x4 gable trim flush with the top of the roof sheathing on both end walls. Use 8d galv. nails

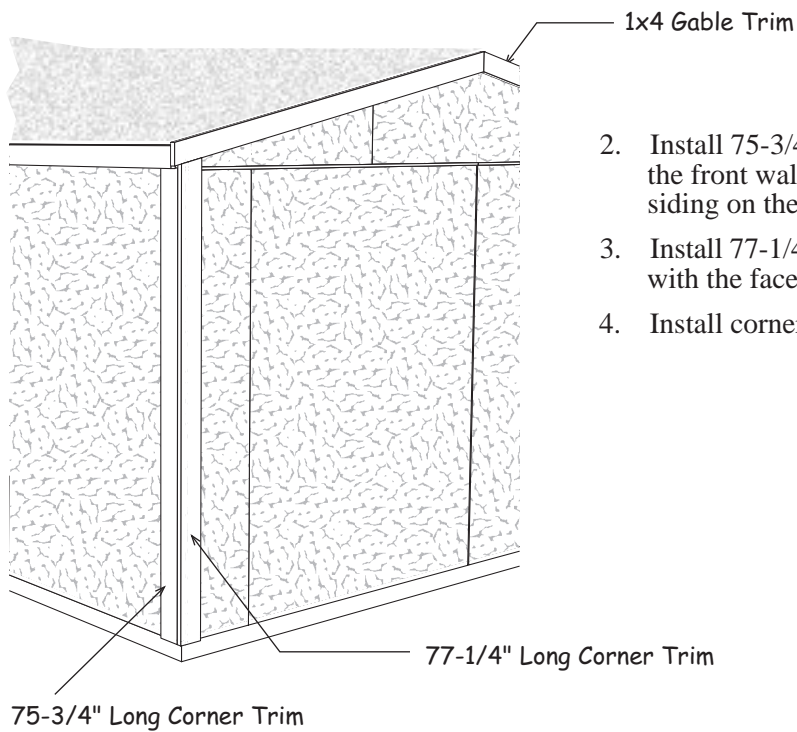

2. Install 75-3/4" long 1x4 corner trim, on the front wall, flush with the face of the siding on the end walls.
3. Install 77-1/4" long 1x4 corner trim, flush with the face of the FRONT wall trim.
4. Install corner trim on the other corners.

Siding Will Extend Below Trim

5. Install (2) two 72" long 1x4 trim boards, flush with the bottom of the siding, along each side of the door opening. Use 8d galv. nails. Tack these boards with a couple nails; you may want to move the trim later when you install the doors.
6. Install a 72" long 1x4 trim board across the top of the door opening

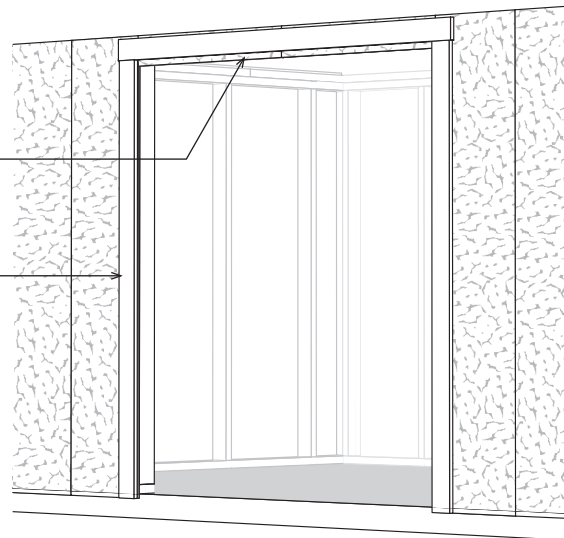

Step 16 Install Doors & Hardware

1. Before you fasten the hinges to the door trim, temporarily prop the doors in the opening. Leave a space at the top of the doors and between the doors and the side trim to allow room for the doors to expand when they absorb moisture.

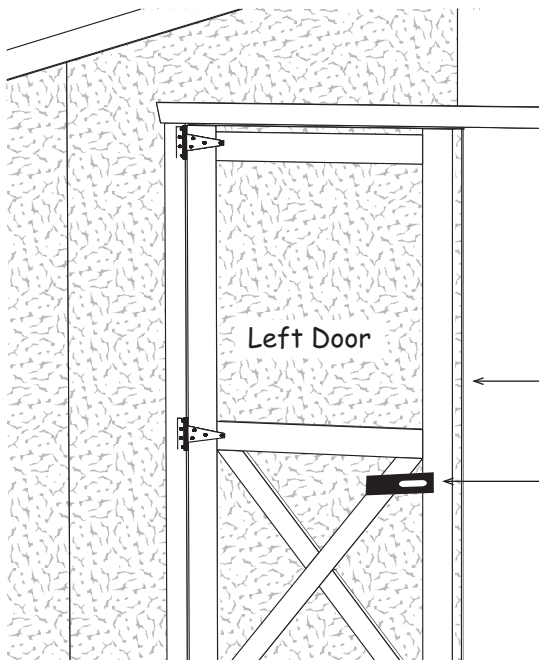

If your door opening is out of square, the space around the doors will not be even. You can remove and reposition the side trim to make allowances for this. The side trim does not have to be flush with the frame of the door opening. You can move the trim in or out to make the door spacing equal. Secure hinges to door trim with 2" screws.

2. Install a barrel bolt on the lower back of the door to secure this door in place when closed. You will need to drill a hole for the round shaft to drop into.
3. Install another barrel bolt at the top of the door.

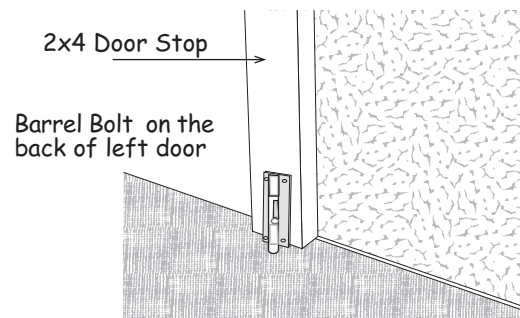

Install metal roof edging perimeter of the roof area. Install shingles according to the instructions on the wrapper. If you need more detailed instructions on installing shingles, there are good publications at book stores, newsstands or youtube.com.

Crestview & Lynwood

Packing List for 10' x 16'

Qty.	Description	Size
	2x4 Framing	
4	Tie Plates (attached to pallet)	78 "
18	Truss Rafters	62 "
44	Wall Studs & Plate Material	72 "
8	Plate Material	68 1/2"
13	Plate Material	60 "
6	Plate Material	48 "
6	Blocks for truss jig	10" to 12"
1	Pre-built Door Header	67 1/2"
2	Pre-built Barn Doors	32" x 72"
	LP Exterior Siding	
9	Pcs. 48" x 75-3/4" Sidewall Siding	
2	Pcs. 36" x 75-3/4" Sidewall Siding	
2	Pcs. 16" x 75-3/4" Sidewall Siding	
2	Pcs. 12" x 75-3/4" Sidewall Siding	
2	Pcs. 4-3/4" x 32-1/4" Siding Above Door	
2	Pcs. 48" x 19-3/4" Gable Siding - angle cut	
4	Pcs. 38" x 14-1/2" Gable Siding - angle cut	

Qty.	White Pine Trim	Size
4	1x4 Gable Trim	64 3/8"
4	1x4 Corner Trim	77 1/4"
4	1x4 Corner Trim	75 3/4"
3	1x4 Door Side Trim	72 "
5	1x4 Collar Ties	72 "
2	1x4 Fascia Trim	72 "
2	1x4 Fascia Trim	74 "
2	1x4 Fascia Trim	48 "
	Hardware	
3	lb. 10d Sinkers	6 4" Hinges
3	lb. 7d Sinkers	1 4" Door Hasp
3	lb. 8d Galv.	2 Barrel Bolts
1	lb. 6d Galv.	18 7/16" Plyclips
1	lb. 6d Common	50 Hinge Screws
4	'Z' Flashing - 60"	50 2-1/2" Screws
	7/16" Roof Sheathing	
4	48" x 72"	8 15" x 48"
2	48" x 48"	
16	8" x 24" Wood Gussets	

Material Purchased By Owner			
7	bdl.	Roof Shingles	7 pcs. Roof 'drip' edge