

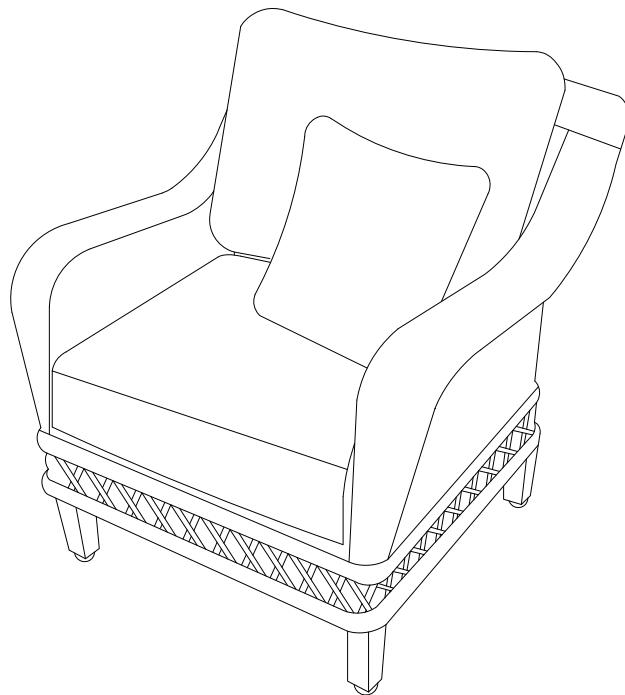

Item #1000 239 682/1000 239 744
Model #D9127-3PC/D9127-3PCR

USE AND CARE GUIDE

WOODBURY LOUNGE CHAIR



Questions, problems, missing parts? Before returning to the store,
call Hampton Bay Customer Service
8 a.m. - 7 p.m., EST, Monday-Friday
9 a.m. - 6 p.m., EST, Saturday

1-855-HD-HAMPTON

HAMPTONBAY.COM

THANK YOU

We appreciate the trust and confidence you have placed in Hampton Bay through the purchase of this lounge chair. We strive to continually create quality products designed to enhance your home. Visit us online to see our full line of products available for your home improvement needs. Thank you for choosing Hampton Bay!

Table of Contents

Table of Contents.....	2	Assembly.....	5
Safety Information.....	2	Care and Cleaning.....	6
Warranty.....	2		
What is Covered.....	2		
What is Not Covered.....	2		
Pre-Assembly.....	3		
Planning Assembly.....	3		
Hardware Included.....	3		
Lounge Chair Package Contents.....	4		

Safety Information

 **CAUTION:** Read all of the instructions in this manual before you begin assembly. Failure to do so may result in faulty assembly and potential injury!

Warranty

THIS IS A RESIDENTIAL WARRANTY ONLY AND THIS WARRANTY DOES NOT APPLY TO COMMERCIAL USE

5 YEAR FRAME LIMITED WARRANTY/2 YEAR RESIN WEAVE AND FABRIC LIMITED WARRANTY

WHAT IS COVERED

We warrant the frame to be free of manufacturing defects to the original purchaser for five years and the resin weave and fabric for two years.

WHAT IS NOT COVERED

It remains the customer's responsibility for freight and packaging charges to and from our service center.

This warranty does not cover commercial use, hardware, acts of nature, fire, freezing, and abusive use.

In addition, purchased parts are not covered under this warranty. We reserve the right to make substitutions with similar merchandise, if the model in question is no longer in production.

For a copy of our full limited warranty, please contact our customer service team below.

Contact the Customer Service Team at 1-855-HD-HAMPTON or visit www.hamptonbay.com.

Pre-Assembly

PLANNING ASSEMBLY

Please read this entire instruction manual prior to assembly.

Identify all parts packed in the carton against the parts list. Remove all protective materials and place the parts on a non-abrasive surface to avoid scratching.



NOTE: More than one person may be required to complete the assembly of this product.

HARDWARE INCLUDED



NOTE: Tools not shown to actual size.

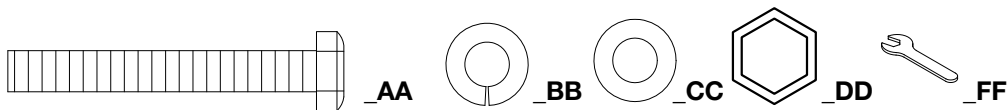

Part	Description	Quantity
AA	M6*45 Hex bolt	8
BB	Spring Washer	8
CC	Washer	8
DD	Cap	8
FF	M6 Wrench	1

Pre-Assembly (continued)

PACKAGE CONTENTS

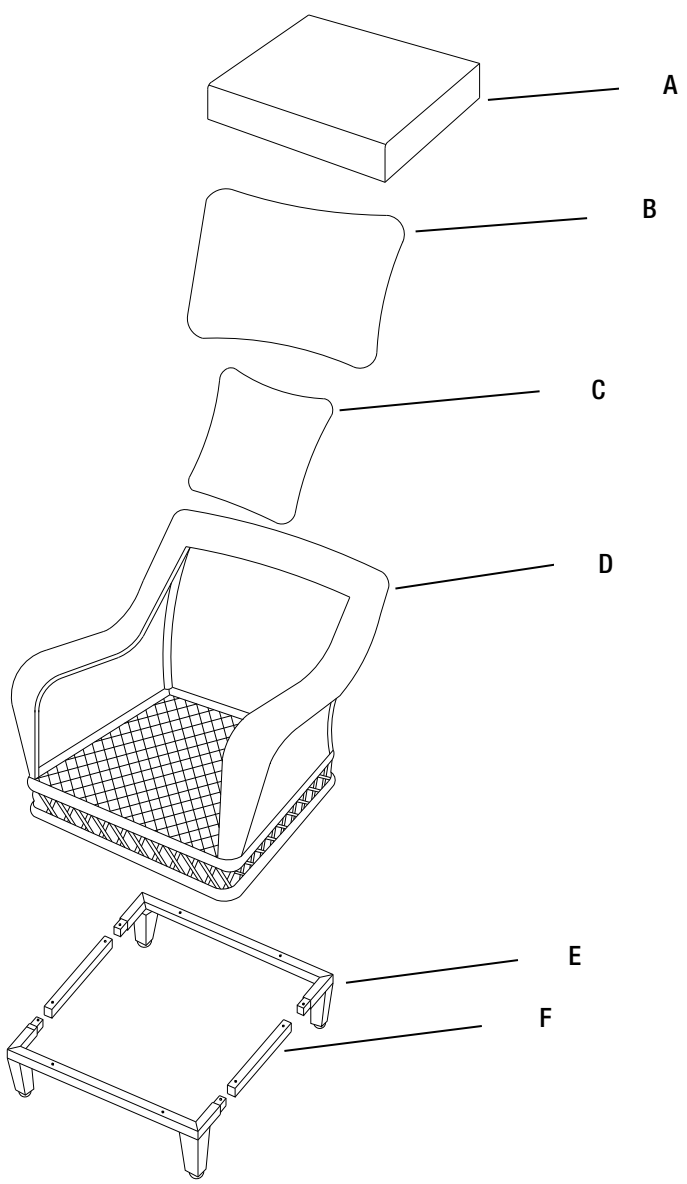

Part	Description	Quantity
A	Seat cushion	1
B	Back cushion	1
C	Pillow	1
D	Lounge chair body	1
E	Leg	2
F	Leg connector	2

Assembly

1 Assembling the legs

- Assemble the legs (E) with the leg connectors (F).



NOTE: No screws are needed in this step.

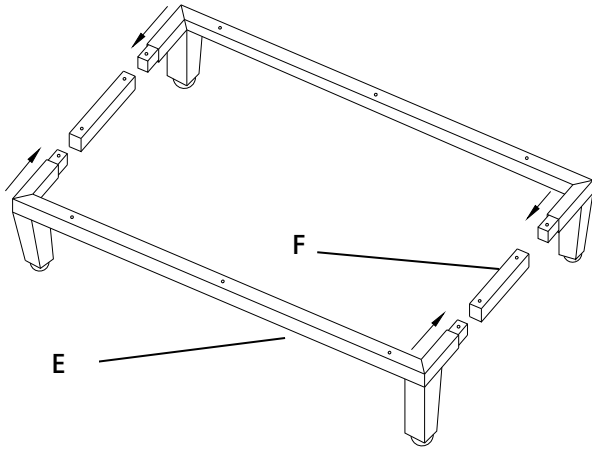

2 Attaching the legs to the lounge chair body

- Place the lounge chair body (D) on a soft, flat non-abrasive surface. Attach the legs (E) and leg connectors (F) to the lounge chair body (D) using M6 hex bolts (AA), spring washers (BB), and washers (CC).



NOTE: Please ensure all the bolts are assembled correctly and use the M6 wrench (FF) to tighten.

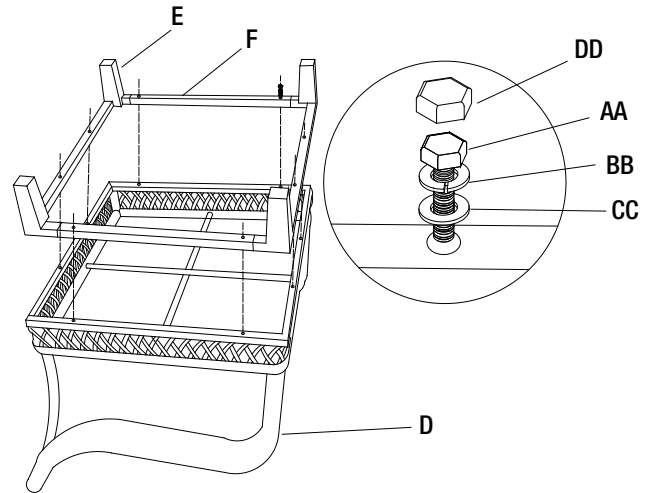

3 Positioning the lounge chair and adding the cushions

- Turn the lounge chair over and set it down on its legs.
- Place the seat cushion (A), back cushion (B) and pillow (C) on the lounge chair.

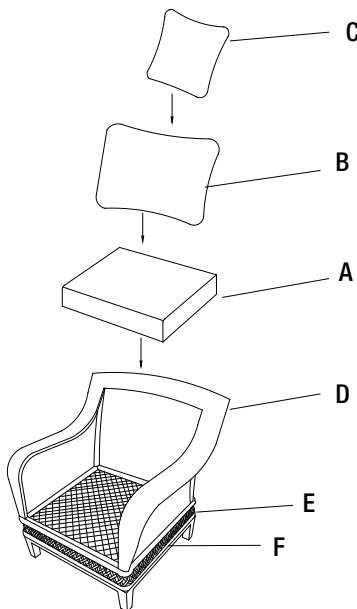

Care and Cleaning

- Do not allow water to build up in the frames. This will cause corrosion and possible freezing damage in cold climates.
- Use a mild soap and water for normal cleaning. Do not use janitorial or alcohol based cleaners. Some cleaners may be marked as natural, but some ingredients may cause discoloration or have an adverse reaction to your finish.
- Rinse with clean water and dry with a soft, absorbent cloth towel.
- Treat the frames with a liquid wax for maximum protection against UV rays and/or salty, damp air.



Questions, problems, missing parts? Before returning to the store,
call Hampton Bay Customer Service
8 a.m. - 7 p.m., EST, Monday-Friday
9 a.m. - 6 p.m., EST, Saturday

1-855-HD-HAMPTON

HAMPTONBAY.COM

Retain this manual for future use.



Item #1000 239 682/1000 239 744
Model #D9127-3PC/D9127-3PCR

USE AND CARE GUIDE

WOODBURY SIDE TABLE

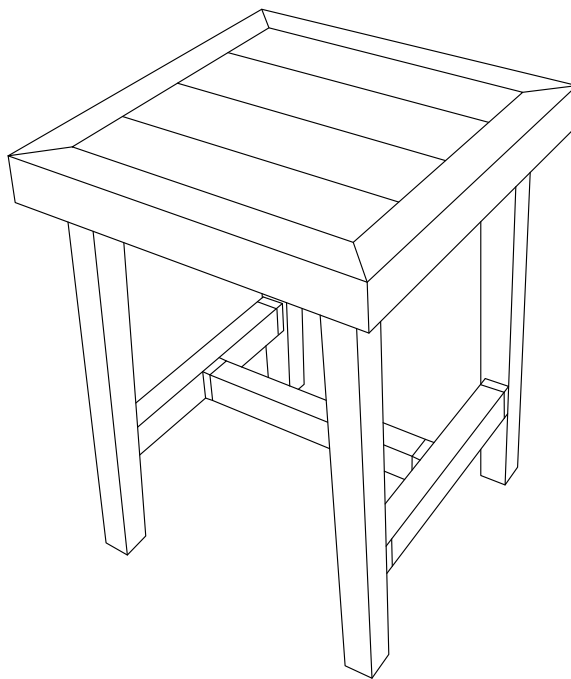

Questions, problems, missing parts? Before returning to the store,
call Hampton Bay Customer Service
8 a.m. - 7 p.m., EST, Monday-Friday
9 a.m. - 6 p.m., EST, Saturday

1-855-HD-HAMPTON

HAMPTONBAY.COM

THANK YOU

We appreciate the trust and confidence you have placed in Hampton Bay through the purchase of this side table. We strive to continually create quality products designed to enhance your home. Visit us online to see our full line of products available for your home improvement needs. Thank you for choosing Hampton Bay!

Table of Contents

Table of Contents.....	2	Pre-Assembly.....	3
Safety Information.....	2	Planning Assembly.....	3
Warranty.....	2	Hardware Included.....	3
What is Covered.....	2	Table Package Contents.....	4
What is Not Covered.....	2	Assembly.....	5
		Care and Cleaning.....	6

Safety Information

 **WARNING:** Do not place heavy items on the table top.

 **WARNING:** Do not sit or stand on the table top.

Warranty

THIS IS A RESIDENTIAL WARRANTY ONLY AND THIS WARRANTY DOES NOT APPLY TO COMMERCIAL USE

5 YEAR FRAME LIMITED WARRANTY

WHAT IS COVERED

We warrant the frame to be free of manufacturing defects to the original purchaser for five years.

WHAT IS NOT COVERED

It remains the customer's responsibility for freight and packaging charges to and from our service center. This warranty does not cover commercial use, hardware, acts of nature, fire, freezing, and abusive use. In addition, purchased parts are not covered under this warranty. We reserve the right to make substitutions with similar merchandise, if the model in question is no longer in production.

For a copy of our full limited warranty, please contact our customer service team below.

Contact the Customer Service Team at 1-855-HD-HAMPTON or visit www.hamptonbay.com.

Pre-Assembly

PLANNING ASSEMBLY

Please read this entire instruction manual prior to assembly. Identify all parts packed in the carton against the parts list. Remove all protective materials and place the parts on a non-abrasive surface to avoid scratching.



NOTE: More than one person may be required to complete the assembly of this product.

HARDWARE INCLUDED



NOTE: Tools not shown to actual size.

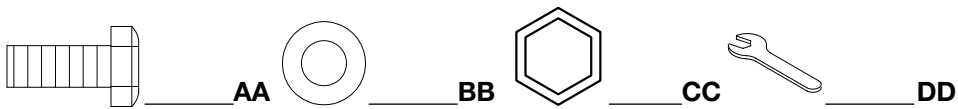

Part	Description	Quantity
AA	M6*15 Hex bolt	14
BB	Washer	14
CC	Cap	14
DD	M6 Wrench	1

Pre-Assembly (continued)

TABLE PACKAGE CONTENTS

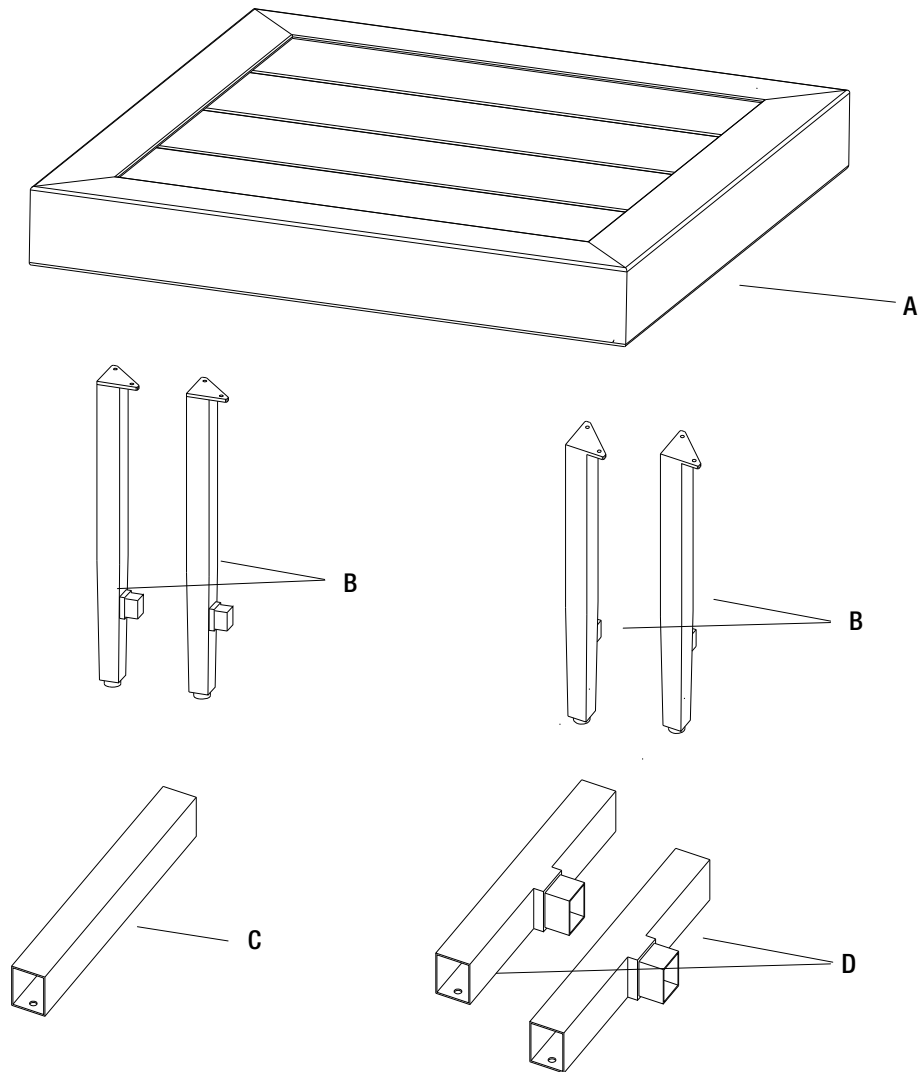

Part	Description	Quantity
A	Table top	1
B	Table leg	4
C	Center connector	1
D	Leg Connector	2

Assembly

1 Attaching the table legs

- Attach a table leg (B) to each end of a leg connector (D) using hex bolts (AA) and washers (BB). Tighten the hex bolts (AA) with the M6 wrench (DD). Attach caps (CC) on hex bolts (AA).
- Assemble the two remaining table legs (B) and the table connector (D) in the same manner.

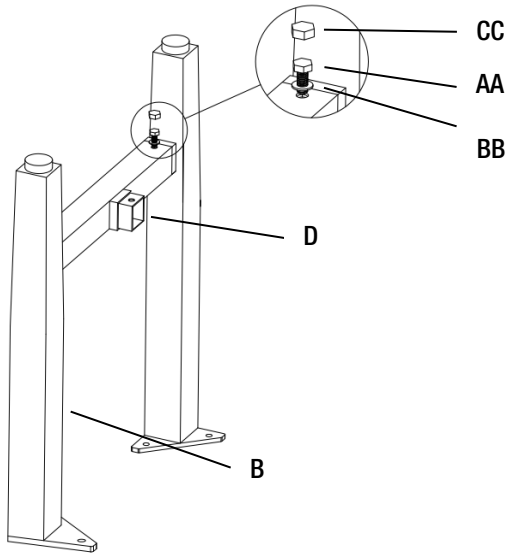

2 Attaching the table legs

- Attach the assembled table legs (B) and leg connectors (D) to each end of the center connector (C) using the hex bolts (AA) and washers (BB). Tighten the hex bolts (AA) with the M6 wrench (DD).

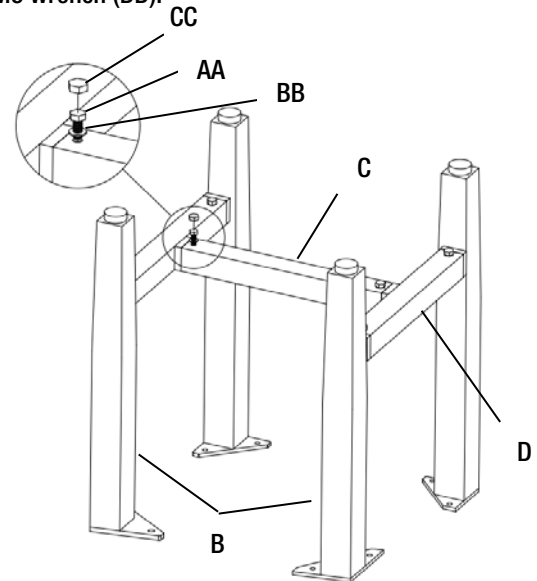

3 Attaching the table top

- Place the table top (A) on a soft, flat non-abrasive surface. Attach the assembled legs (B) to the table top (A) using the hex bolts (AA) and washers (BB). Tighten the hex bolts (AA) with the M6 wrench (DD). Attach caps (CC) on the bolts (AA).

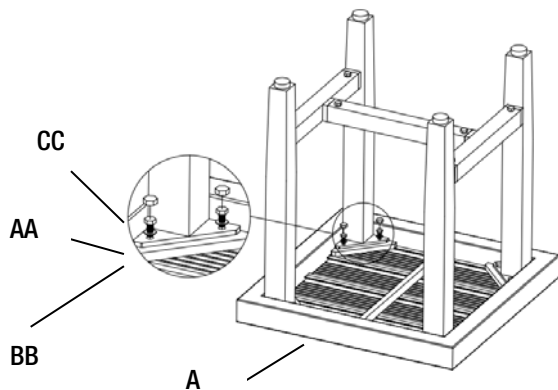

4 Positioning the table

- Turn the table over and set it down on its legs.

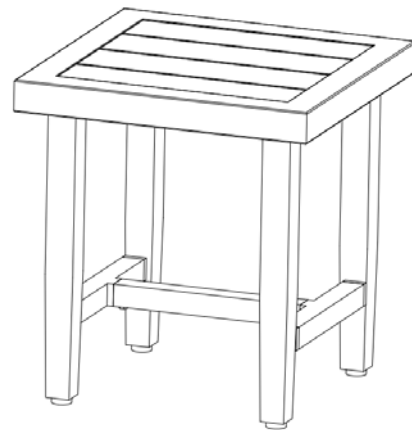

Care and Cleaning

- Do not allow water to build up in the frames. This will cause corrosion and possible freezing damage in cold climates.
- Use a mild soap and water for normal cleaning. Do not use janitorial or alcohol-based cleaners. Some cleaners may be marked as natural, but some ingredients may cause discoloration or have an adverse reaction to your finish.
- Rinse with clean water and dry with a soft, absorbent cloth towel.
- Treat frames with a liquid wax for maximum protection against UV rays and/or salty, damp air.



Questions, problems, missing parts? Before returning to the store,
call Hampton Bay Customer Service
8 a.m. - 7 p.m., EST, Monday-Friday
9 a.m. - 6 p.m., EST, Saturday

1-855-HD-HAMPTON

HAMPTONBAY.COM

Retain this manual for future use.