

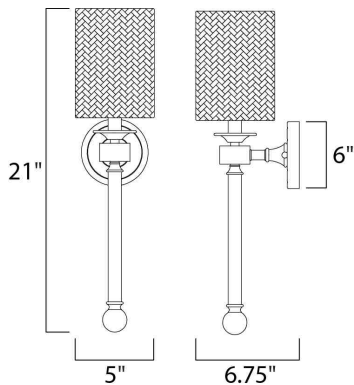

**PRODUCT DESCRIPTION**

Unique and dramatic pendants are created using solid Clear glass rods that fit into castings finished in Polished Nickel. This design is a creative mix of modern and classic which has a broad universal appeal.



**MEASUREMENTS**

DIMENSION : 5." W x 21." H x 6.75" Ext  
 MAX OAH : 6." W x 6." H  
 HANGING WEIGHT : 2.9 lb

**LAMPING**

INPUT VOLTAGE : 110-130V  
 BULB : 1 x 60W (NOT INCLUDED), 60W Total  
 DIMMABLE : Dimmable

**FINISHES OPTION**

Polished Nickel PN



**GLASS**

Clear CL

**MATERIAL**

Steel+Glass

**RATINGS**

ETL / cETL iP65  
 Damp Location  
 Dimmable



**ADDITIONAL**

INSTALL UP/DOWN: Up  
 OPERATING TEMPERATURE:  
 -20°C (-4°F), 40°C (104°F)

Always consult a qualified electrician before installing any lighting product.



**WESTERN DISTRIBUTION CENTER (HEADQUARTER)**  
 253 NORTH VINELAND AVE | CITY OF INDUSTRY, CA 91746

**EASTERN DISTRIBUTION CENTER**  
 4200 SHIRLEY DR. | ATLANTA, GA 30336

P. 626.956.4200 | F. 626.956.4225 | maximlighting.com