



Whirlpool[®]

**Self Cleaning
Hot & Cold Hidden
Bottle Water Cooler**

Model No.: 8LIECH-SCSSFP5W

USER MANUAL

**SAVE THIS MANUAL FOR
FUTURE USE**

For service call: 1-844-494-4757

SAFETY PRECAUTIONS

Your safety and the safety of others are very important.

We have provided many important safety messages in this manual and your appliance. Always read and follow all safety messages.



This is the safety alert symbol.

This symbol alerts you to potential hazards that can kill or hurt you and others.

All safety messages will follow the safety alert symbol and either the word "DANGER" or "WARNING"

These words mean:

▲ DANGER

You can be killed or seriously injured if you don't immediately follow the instructions.

▲ WARNING

You can be killed or seriously injured if you don't follow the instructions.

All safety instructions will inform you what the potential hazard is, how to reduce the chance of injury, and what can happen if the instructions are not followed.

IMPORTANT SAFETY INSTRUCTIONS

WARNING: To reduce the risk of fire, electric shock, or injury when using your water cooler, follow these basic precautions:

- Plug it into a grounded 3-prong outlet.
- Do not remove the ground prong.
- Do not use an adapter.
- Disconnect the power before servicing.
- Replace all the parts and the panels before operating.
- Do not use an extension cord.
- Two or more people should move and install the water cooler and the bottles.

SAVE THESE INSTRUCTIONS

When operating this dispenser, please observe the following:

- Prior to use, this dispenser must be properly assembled and installed in accordance to the instructions indicated in this manual.
- This dispenser is intended only for water dispensing. Do NOT use other liquids. Do NOT use for other purposes. Never use other liquids in the dispenser other than known and microbiologically safe bottled water. Warranty is void if used with any other liquids, such as coffee, tea, juices, beer or wine.
- **Location Requirements:**
 - Install in an area that is sheltered from harsh weather conditions, including direct sunlight.
 - Install and use only on a hard, flat and level surface.
 - Do NOT place the dispenser inside an enclosed space or cabinet.
 - Position the dispenser no closer than 4 inches from the wall with at least 4 inches clearance on the sides to permit free airflow.
 - Service should only be performed by a certified technician. Please contact us at 1-844-494-4757 for assistance.

IMPORTANT: Do NOT Return Dispenser To Store.

If you have a question or problem, please contact 1-844-494-4757 for assistance.

SAFETY PRECAUTIONS ---Electrical Requirements

⚠ WARNING



Electrical shock Hazard

Plug into a grounded 3 prong outlet.
Do not remove ground prong.
Do not use an adapter.
Do not use an extension cord.
Failure to follow these instructions can result in death, fire, or electrical shock.

A 120 volt, 60 Hz., AC only, 15 amp, fused electrical supply is required. A time-delay fuse or circuit breaker is recommended.

If codes permit and a separate ground wire is used, it is recommended that a qualified electrician determine that the ground path is adequate.

Check with a qualified electrician if you are not sure if the water cooler is properly grounded.

The proprietary design of the hot water tank assures availability of hot water and efficient energy use.

PRODUCT FEATURES

Congratulations! You have chosen an Advanced Technology State of the Art Water Cooler.

To provide consistently cold water, this water cooler forms an "Ice Bank" in the cold tank. Formation of the initial "Ice Bank" can take up to 6 hours.

WHEN THE UNIT IS PLUGGED IN FOR THE FIRST TIME IT CAN TAKE UP TO 6 HOURS BEFORE THE "ICE BANK " FORMS AND THE UNIT CAN PROVIDE THE COLDEST WATER.

IMPORTANT: Do NOT Return Dispenser To Store.
If you have a question or problem, please contact 1-844-494-4757 for assistance.

TABLE OF CONTENTS

Safety Precautions	2
Safety Precautions-Electrical Requirements	3
Product Features	3
Key Information for Future Use	4
Specifications	5
Parts & Features	5
Unpacking and Assembly	6
Installation	6
Cleaning Prior to Initial Use	7
Operation	8
Proper Care & Cleaning	11
Troubleshooting	15
Limited Warranty	18

KEY INFORMATION FOR FUTURE USE



Please register your dispenser immediately at www.electrotemp.com

For future support, please record your serial number (located on the label at the back of the dispenser) and purchase date. Staple your receipt to the manual.

You will need this information to obtain warranty service.

Product **Self Cleaning Hot & Cold Hidden Bottle Water Cooler With Display**

Model Number **8LIECH-SCSSFP5W**

Serial ID Number _____

Date of Purchase _____

IMPORTANT: Do NOT Return Dispenser To Store.
 If you have a question or problem, please contact 1-844-494-4757 for assistance.

SPECIFICATIONS



Version 2.0

Energy
Verified

Power Supply	8Amp.
Refrigerant Type	R-134A
Cold Water Power	< 100 Watts
Cold Capacity / Hour	6 Litres / 1.59 Gallon
Cold Temperature	3°C - 10°C / 37.4°F - 50°F
Hot Water Power	870 Watts
Hot Capacity / Hour	8 Litres / 2.11 Gallon
Hot Temperature	80°C - 92°C / 176°F - 197.6°F
Dimensions	1028 H x 320 W x 382 D (mm) 40.5 H x 12.6 W x 15 D (inch)
Net Weight	36.2 lbs / 16.4 Kg

PARTS & FEATURES

- Control: Hot Water (1)
- Hot Water Release (2)
- Control: Cold Water (3)
- Hidden Faucet or tap (hot water) (4)
- Hidden Faucet or tap (cold water) (5)
- LED Night Lights (6)
- Drip Tray (7)
- Door (8)
- Bottle Tray (9)
- Hot Power Switch (Energy Saving) (10)
- Cold Power Switch (Energy Saving) (11)
- Carry Handle (12)
- Drain Plug (13)
- Bottle Probe (14)
- Sensor Switch (15)
- Water pump (16)
- Power Cord (17)
- Condenser (18)

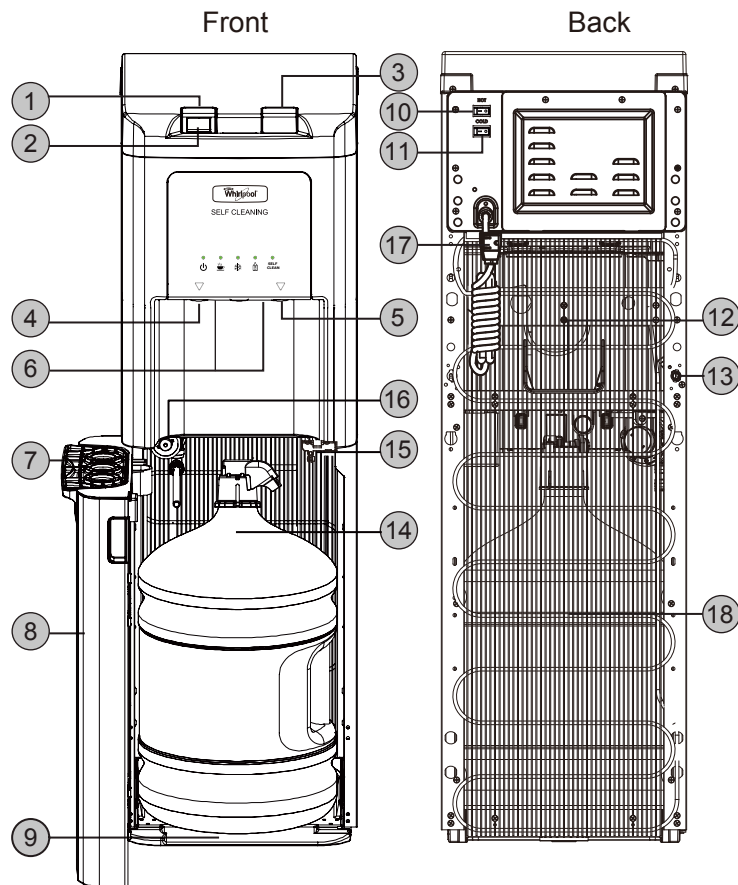

IMPORTANT: Do NOT Return Dispenser To Store.

If you have a question or problem, please contact 1-844-494-4757 for assistance.

UNPACKING AND ASSEMBLY

Remove the dispenser from packaging:

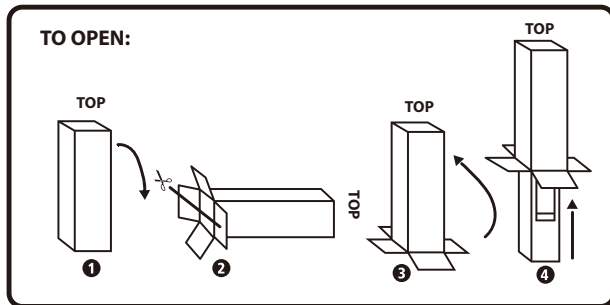

1. Lay dispenser on its side.
2. Open bottom flaps of the cardboard box.
3. Stand cooler up with flaps unfolded.
4. Pull box straight up.
5. Unpack the drip tray and insert it into the dispenser.
6. Keep original packing for the duration of warranty.

⚠ WARNING

Excessive Weight Hazard

Use two or more people to move and install the water cooler and the bottles.

Failure to do so can result in back or other injury.

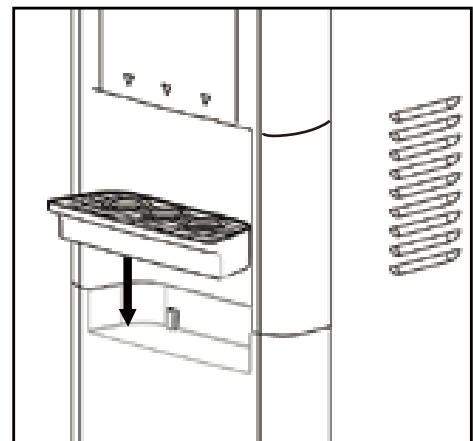

INSTALLATION

⚠ WARNING

Excessive Weight Hazard

Use two or more people to move and install bottles.

Failure to do so can result in back or other injury.

1. Place the dispenser on a hard and level surface in a cool shaded location near a grounded wall outlet.

Notice: Do NOT plug in the power cord yet.

2. Position dispenser so that the back is at least 4 inches from the wall and there are at least 4 inches of clearance on both sides.
3. To minimize vibration and noise, make sure that the dispenser is flat.

Notice: Do NOT plug in power cord yet.

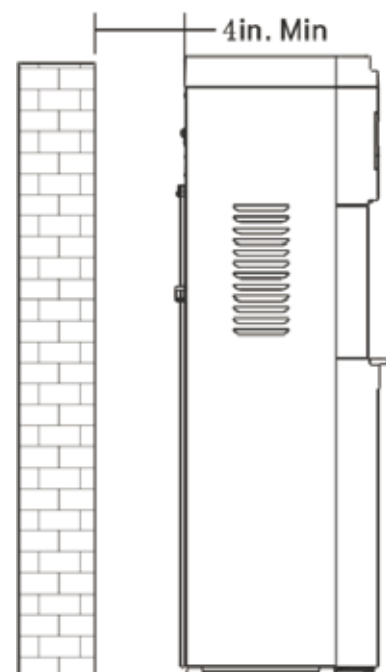

IMPORTANT: Do NOT Return Dispenser To Store.

If you have a question or problem, please contact 1-844-494-4757 for assistance.

CLEANING PRIOR TO INITIAL USE

To remove any odors or dust that may have accumulated during shipment, you may want to clean the dispenser prior to first use.

Time Required: 45 minutes.

Notice: Do NOT plug in power cord yet.

1. Move the dispenser away from the wall and turn it 90° in either direction.
2. Turn the power switches to OFF.
3. Remove the water bottle and the probe from the water bottle.
4. Place a 2 gallon or larger bucket under the probe assembly.
5. Referring to the figure to the right, take apart the probe assembly parts "A" and "B", wash the probe parts by hand in soapy water or in the dishwasher.
6. Remove the air filter and wash it in soapy water.
7. Submerge the probe hand in the soapy water and rinse properly.
8. Reattach all parts of the probe assembly.
9. Spray the dispensing nozzles of water faucets with chlorine solution (1 teaspoon of unscented bleach composition (I.E.5.25% sodium hypochlorite) in a glass of water).
10. Place a 2 gallon or larger bucket under the drain plug in the rear of the dispenser.
11. Once the unit has been drained, replace the drain plug and drain the cap.
12. Remove remaining water from the reservoirs by dispensing it from the cold tap into a pitcher.

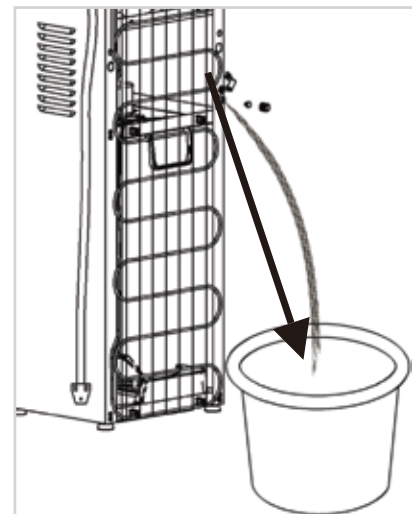
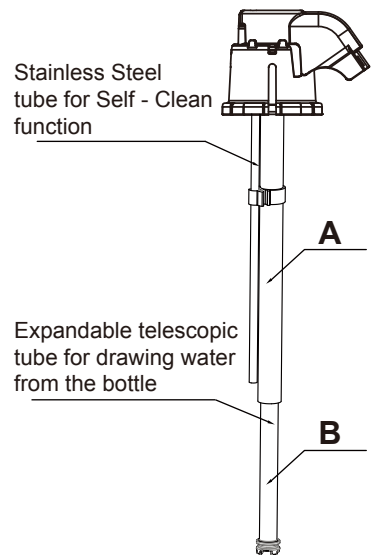

Pre-Rinsing the Water System

13. Fill bottle with 2 gallons of tap water.
14. Insert probe assembly, place bottle into water cooler and close the door.
15. Allow cooler to be filled with water.
16. Drain water out as in steps 10, 11 and 12 of "Cleaning Prior To Initial Use" section.
17. If chlorine taste persists, repeat rinsing procedure.
18. Complete the installation and follow the operation instructions indicated in this manual. If your water has an off-taste, do not return the dispenser to the store. Call 1-844-494-4757 for assistance.

IMPORTANT: Do NOT Return Dispenser To Store.
If you have a question or problem, please contact 1-844-494-4757 for assistance.

OPERATION

IMPORTANT

This unit is intended for water dispensing only. Do NOT use other liquids. Do NOT use for other purposes. Warranty is void if used with any other liquids such as coffee, tea, juices, beer or wine.

This dispenser has been designed to use water bottles with a 3, 5, or 5.2 gallon capacity. Do NOT use alternative bottles.

Initial Set Up

Do NOT plug in until steps 1-2 are completed.

⚠ WARNING

<p>Electrical shock Hazard</p> <p>Plug into a grounded 3 prong outlet.</p> <p>Do not remove ground prong.</p> <p>Do not use an adapter.</p> <p>Do not use an extension cord.</p> <p>Failure to follow these instructions can result in death, fire, or electrical shock.</p>

⚠ WARNING
<p>Excessive Weight Hazard</p> <p>Use two or more people to move and install the water cooler and the bottles.</p> <p>Failure to do so can result in back or other injury.</p>

1. Allow the unit to sit upright for 4 hours. Make sure unit is in the off position and is upright for at least 4 hours prior to plugging the unit in.
2. This model uses a pump to deliver water from the bottle to the reservoirs:
 - i. Clean the bottle cap and neck.
 - ii. Remove the entire plastic cap from bottle.
 - iii. Adjust the length of the probe by pulling the B portion of the tube to its maximum extension. Insert the probe into the bottle and push it down. The probe will self-adjust to its appropriate length. (See illustration on right).
 - iv. Push down the probe head until it is seated.
 - v. Plug power cord into the wall outlet.

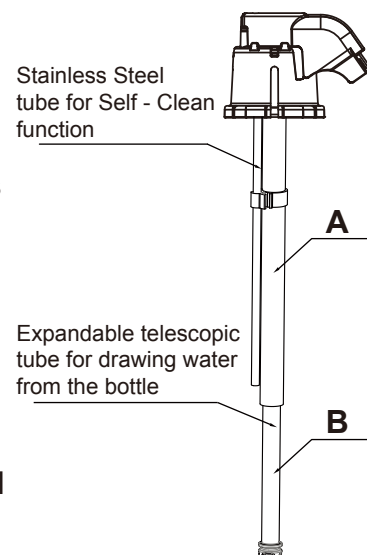
Note: At initial start-up, it will take about 3 minutes for the reservoirs to fill with water.



IMPORTANT: Do NOT Return Dispenser To Store.
If you have a question or problem, please contact 1-844-494-4757 for assistance.

NOTE: When using a 5 gallon rectangular bottle, slide it into place as shown in the illustration below.

- If the probe tube A and B(see previous page) are not sealed, the pump will run a few minutes and the night lights will flash. To correct, open the door, re-attach the probe, and close the door.
- If the lights continue to flash, your bottle may be empty or there may be an issue with the water tube lines. Call 1-844-494-4757 for assistance.

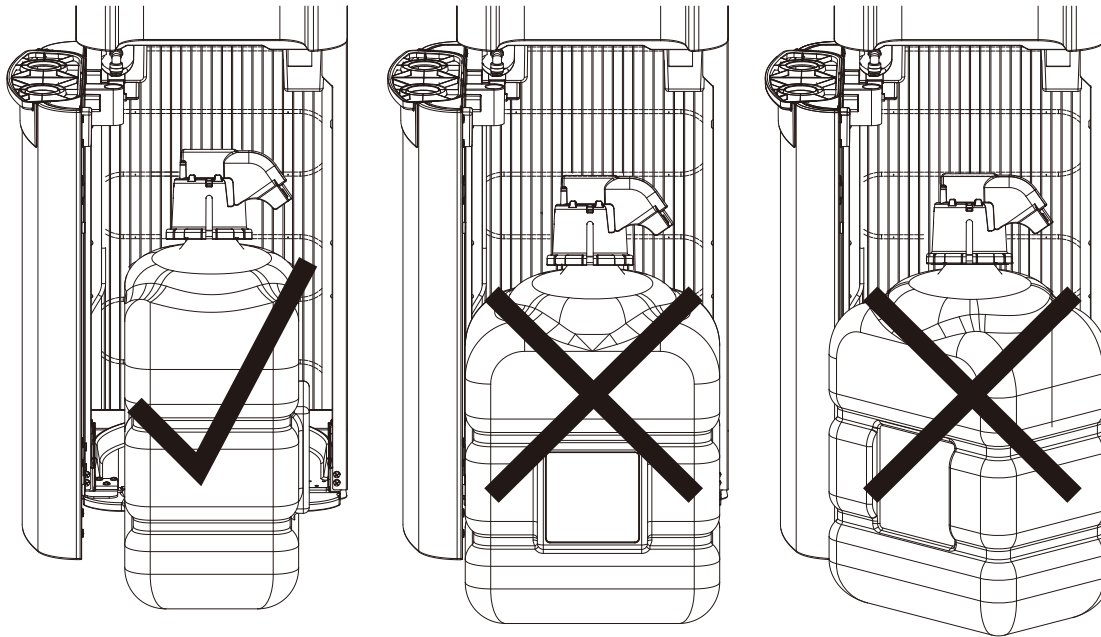

3. Turn the switches at the back of the dispenser to ON.

- The red switch controls the hot water. If you do not want hot water, leave this switched OFF.
- The blue switch controls the cold water. If you do not want cold water, leave this switched OFF.

Note:

- For the unit to operate properly, the probe head must seal on the bottle and the door must be fully closed.
- It will take up to 3 minutes for the reservoirs to fill with water. During this time, the pump will run on and off. This is normal.
- Each time you dispense water from the taps, the pump will turn on to refill the tanks. This is normal.
- Self Cleaning works every 4 hours for short time. Self Cleaning pump sound is normal.

IMPORTANT: Do NOT Return Dispenser To Store.
If you have a question or problem, please contact 1-844-494-4757 for assistance.

Dispensing Cold Water

Note: After setup, it will take up to 6 hours to get the water to its maximum cold temperature. During this time, the compressor may run continuously as the refrigeration system builds the "Ice Bank" as noted in the "Product Features" section.

1. Position the bottle, glass, pitcher, or any container you are wishing to fill with water, securely below the cold water tap.
 - The right triangle below the cold water control indicates the location of the cold water tap(See the "Parts & Features" section #5).
 - The circular shapes in the drip plate help align the flow of water. This unit dispenses water at a fast rate. To avoid splashes, hold the cup as close to the tap as possible.
2. Press the right control downward to start dispensing water.
3. Release the control once desired fill level is achieved.

Dispensing Hot Water

Note: After setup, hot water will be available in 15-20 minutes.

1. Position the bottle, glass, pitcher or any container you are wishing to fill with water, securely below the hot water tap.
 - The left triangle below the hot water control indicates the location of the hot water tap(See the "Parts & Features" section #4).
 - The circular shapes in the drip plate help align the flow of water. To avoid splashes, hold the cup as close to the tap as possible.
2. Push the hot water release button (red) inward and press the control downward to start dispensing water.
3. Release the control once desired fill level is achieved.

Replacing an Empty Bottle

Note: When your water bottle is empty, the dispenser will beep intermittently and the LED night lights will blink until a fresh bottle is connected.

You may also hear a sucking sound when the bottle is empty and needs changing. This is normal and is another way to be alerted that your bottle is empty and needs to be replaced.

Replace the bottle as soon as you notice that it is empty. If a new bottle is unavailable, leave the door ajar or unplug the cooler to stop the beeping noise and flashing lights.

IMPORTANT: Do NOT Return Dispenser To Store.
If you have a question or problem, please contact 1-844-494-4757 for assistance.

There may be a small amount of water left in the bottle. This is normal.

1. Open door and slide bottle out.
2. Remove the probe from the bottle:
 - Pull the probe straight up until completely out of bottle.
3. Install fresh bottle:

⚠ WARNING

Excessive Weight Hazard
Use two or more people to move and install bottles.
Failure to do so can result in back or other injury.

- Place the fresh bottle in front of the tray.
- Clean the fresh bottle using a soft cloth and warm soapy water and then rinse.
- Remove the entire plastic cap from the top of the bottle.
- Insert the probe into bottle.
- Push the probe down until it is seated.
- Slide the bottle onto the tray and close the door completely.

PROPER CARE & CLEANING

General Cleaning

Perform: As needed

Time Required: 5 minutes.

Note: Do NOT use abrasive materials or chemical cleaners.

1. Clean cabinet surfaces with a soft cloth and warm soapy water.
2. Wipe dust from back of dispenser to improve efficiency.
3. Remove drip tray assembly by sliding it forward. Remove cover. Place tray and cover in dishwasher or wipe parts clean with a soft cloth and warm soapy water.
4. Reattach drip tray assembly.

Your Bottom Loading cooler has the following noise emitting functions:

Self-Cleaning pump noise:

1. When a cooler without a display is plugged in, the air pump for an ozone delivery starts to work and lasts for 12 seconds. After start up. It will work every 4 hours for the same period of time. Coolers with a display are programmed to have the ozone delivery pump work every 4 hours starting from 12 o'clock.

IMPORTANT: Do NOT Return Dispenser To Store.
If you have a question or problem, please contact 1-844-494-4757 for assistance.

2. The water pump delivers water to the cold tank. Besides a low humming pump noise, the sound of water running into the cold tank, can also be heard.
3. When the Hot Power Switch (see Parts and Features Section) is turned on, sounds of normal expansion and contraction of metal parts may be heard as the water is heated.
4. The refrigeration compressor works when water needs to be cooled. It has a very low pitch humming noise like that of your refrigerator.
5. In some cases, noise resulting from the installation on hard flooring is present. A noise-absorbing mat is supplied to place under the cooler.

Sanitizing

Perform: Every 3 months or whenever an off-taste occurs.

Time Required: 30 minutes.

Note: Best done prior to loading a fresh bottle.

Step A: Remove Existing Water

1. Move the dispenser away from the wall and rotate it so that the drain plug is accessible.
2. Turn the power switches to OFF.
3. Unplug the power cord from the wall outlet.
4. Remove water bottle and probe from water bottle.
5. Place a 2 gallon or larger bucket under the drain plug in the rear of the dispenser.
6. Use a screw driver to remove screw holding drain tap and remove drain plug. Cold water will immediately flow into the bucket. After several seconds, hot water will dispense.
7. Reminder – place the drain cap and plug in a safe location so that they will not be lost.
8. Once the unit has been drained, replace the drain plug and the drain cap and secure using the screw.
9. Remove the remaining water from the reservoir by dispensing from the cold tap into a pitcher.

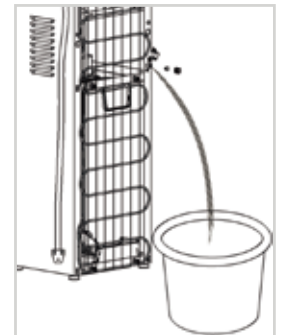

Step B: Sanitize Probe and Taps

1. In a clean container, make a sanitizing solution of 1.5 gallons of tap water and 1.5 tablespoons of unscented household bleach composition (I.E. 5.25% sodium hypochlorite).
2. Wipe the probe and the area around all the taps with a soft cloth moistened with the sanitizing solution.

Step C: Sanitize Reservoirs

1. Remove the cap from a spare empty 5 gallon bottle.

IMPORTANT: Do NOT Return Dispenser To Store.
If you have a question or problem, please contact 1-844-494-4757 for assistance.

2. Fill the bottle with the water and bleach mixture.
3. Insert the probe into the bottle.
4. Slide the bottle into the cabinet and close the door.

⚠ WARNING

Electrical shock Hazard
<p>Plug into a grounded 3 prong outlet.</p> <p>Do not remove ground prong.</p> <p>Do not use an adapter.</p> <p>Do not use an extension cord.</p> <p>Failure to follow these instructions can result in death, fire, or electrical shock.</p>

5. Plug the power cord into a grounded wall outlet.
6. Turn the energy saving switches ON.
7. Allow the water and bleach mixture to fill up the empty reservoirs.
8. Wait 10 minutes then turn the energy saving switches OFF and unplug the power cord.
9. Dispense 1 cup of the water/bleach solution through each tap to clean out the waterways.
10. Place a 2 gallon or larger bucket under the drain plug in the rear of the dispenser.
11. Remove the drain cap and the drain plug. Cold water will immediately flow into the bucket. After several seconds, hot water will dispense.

Reminder - place the drain cap and the drain plug in a safe location so that they will not be lost.

12. Once the unit has been drained, replace the drain plug and the drain cap.
13. Remove the remaining water from the reservoir by dispensing from the cold tap into a pitcher.

Step D: Rinse Reservoirs

1. Dispose of the water and bleach mixture and rinse the bottle with tap water.
2. Fill the bottle with tap water and insert the probe into the bottle.
3. Push the probe down until it is seated.
4. Slide the bottle into the cabinet and close the door.

⚠ WARNING
Excessive Weight Hazard
<p>Use two or more people to move and install bottles.</p> <p>Failure to do so can result in back or other injury.</p>

5. Plug the power cord into a grounded wall outlet.

⚠ WARNING

Electrical shock Hazard
<p>Plug into a grounded 3 prong outlet.</p> <p>Do not remove ground prong.</p> <p>Do not use an adapter.</p> <p>Do not use an extension cord.</p> <p>Failure to follow these instructions can result in death, fire, or electrical shock.</p>

IMPORTANT: Do NOT Return Dispenser To Store.
 If you have a question or problem, please contact 1-844-494-4757 for assistance.

6. Turn the energy saving switches ON.
7. Allow the water to fill up the empty reservoirs.
8. Wait 10 minutes then turn the energy saving switches OFF and unplug the power cord.
9. Place a 2 gallon or larger bucket under the drain plug in the rear of the dispenser.
10. Remove the drain cap and the drain plug. Cold water will immediately flow into the bucket. After several seconds, hot water will dispense.

Reminder - place the drain cap and the drain plug in a safe location so that they will not be lost.

11. Once the unit has been drained, replace the drain plug and the drain cap.
12. Remove the remaining water from the reservoir by dispensing from the cold tap into a pitcher.
13. Return the unit to its location, install a fresh water bottle, plug the power cord back into the grounded wall outlet and turn the energy saving switches ON.

LED Indicator Lights

❶ POWER INDICATOR

When the LED light is constantly lit it indicates that power is being supplied to the unit.

❷ HEATER INDICATOR

When the LED light is flashing it indicates that the heating system is working. When the LED light is constantly lit, it indicates that the hot water is ready. When the LED light is off it shows that the heating system is off.

❸ COOLING INDICATOR

When the LED light is flashing it indicates that the cooling system is working. When the LED light is constantly lit, it indicates that the cold water is ready. When the LED light is off it indicates that the cooling system is off.

❹ EMPTY BOTTLE INDICATOR

The LED light is constantly lit when the water bottle has enough water for normal operation. When the LED light is flashing it indicates that the level of water in the bottle is low and a new full bottle should be installed.

❺ SELF CLEAN INDICATOR

When the LED light is flashing it indicates that the self-cleaning takes place. When the LED light is constantly lit it indicates that the self-clean protection is on.

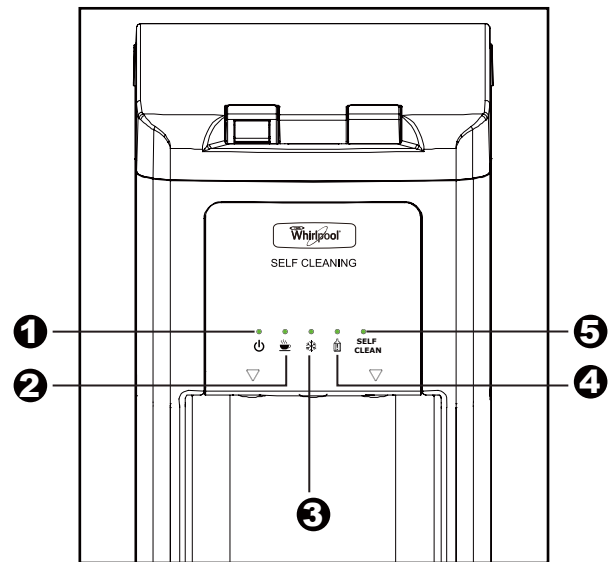

IMPORTANT: Do NOT Return Dispenser To Store.

If you have a question or problem, please contact 1-844-494-4757 for assistance.

TROUBLESHOOTING

Dispenser is not operating.

- Make sure that the power cord is properly connected to a working outlet.
- Confirm that power switches located in the back of unit are ON. They will glow in the ON position if they are on.
- Turn them OFF and ON to make sure that cooler is plugged in and circuit breaker is not tripped. If needed, plug power cord into another receptacle to confirm there is electricity going to the water cooler.

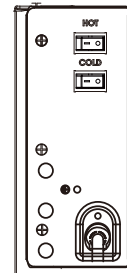

Water is leaking.

- Replace water bottle. Most common cause is a cracked bottle.
- If the leak remains, remove the probe from the bottle and call 1-844-494-4757 for assistance.

Push buttons are stuck.

- Apply mineral oil (baby oil) to the button slides to reduce friction.

No water is coming from the taps.

⚠ WARNING

Excessive Weight Hazard
Use two or more people to move and install bottles.
Failure to do so can result in back or other injury.

- Make sure the water bottle is not empty. If so, replace it. If not, adjust the probe to an appropriate length. Refer to step 2 in “Cleaning Prior to Initial Use” section.
- Make sure that you fully press the water controls.
- Make sure that the probe connection with the water bottle forms a complete seal.
- Make sure that the door is closed.

Water dispensed is not cold.

It takes up to 6 hours after setup to dispense coldest water. Compressor works to build up ice bank, this is normal.

- Make sure that the back of the dispenser is at least 4 inches from a wall and that air is free to flow on all 4 sides of the dispenser.
- Make sure that the cold water switch is ON.

Water dispensed is not hot.

It takes 15-20 minutes after setup to dispense hot water.

- Make sure that the power cord is properly connected to a working outlet.
- Make sure that the hot water switch is ON.

IMPORTANT: Do NOT Return Dispenser To Store.
If you have a question or problem, please contact 1-844-494-4757 for assistance.

LED night lights are flashing and the dispenser is making beeping noises.

- Replace the empty bottle. If unavailable, leave the door ajar or unplug the cooler to stop the beeping noise and the flashing lights.

Dispenser is noisy.

- Make sure that the dispenser is positioned on a level surface.

Water tastes bad.

- Drain the water from the reservoirs and replace the water bottle with a fresh one.
- Clean dispenser as outlined in “ Proper Care & Cleaning ” section.

Cleaning stainless steel.

- This treatment removes and prevents finger prints from marring surface. Please rub in small amount of mineral oil (Unscented Baby oil) wipe clean, it will enrich the looks.

If your pump is not pumping water into cooler.

- Please check if tubing is properly inserted into quick connector at the top of the probe head. (See images below and on page 18 for more information.)

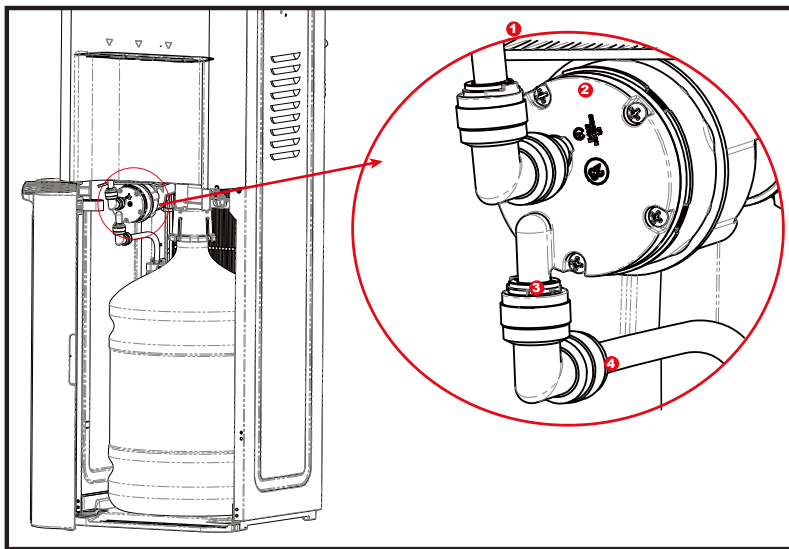

Quick connectors have U-shaped Locks. Remove lock, push tubing in until it stops, place lock back.

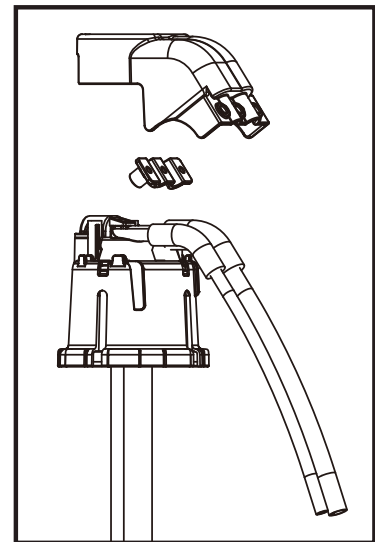

Probe has well secured tubing.

IMPORTANT: Do NOT Return Dispenser To Store.
If you have a question or problem, please contact 1-844-494-4757 for assistance.

How to Connect /disconnect the quick connector and tubes

1. Remove U-shaped lock.

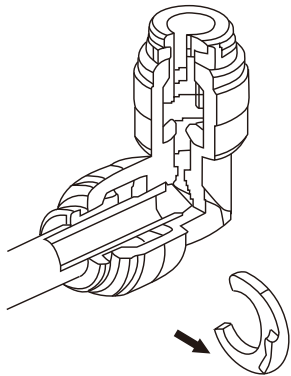

2. Press collet and pull tubing out.

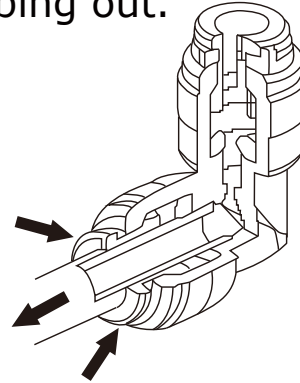

3. If the end of the tubes have burrs, they can be removed by using a pencil sharpener as shown below. Do not create a large taper on the end of the tube because it can cause a leak.

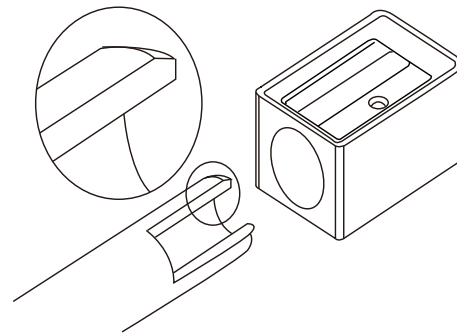
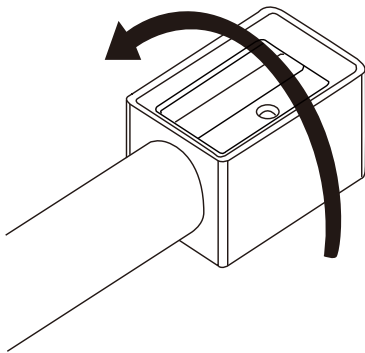

4. Push tubing in until fully seated.

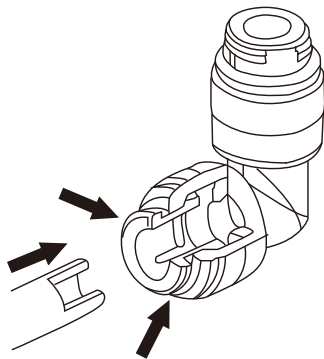

5. Reinstall U-shaped lock.

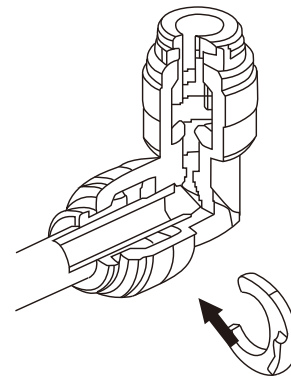

IMPORTANT: Do NOT Return Dispenser To Store.
If you have a question or problem, please contact 1-844-494-4757 for assistance.

LIMITED WARRANTY

Electrotemp Technologies Inc., (“Vendor”) warrants to the original purchaser of this dispenser, and to no other person, that if this dispenser is assembled and operated in accordance with the printed instructions accompanying it, then for a period of one (1) year from the date of purchase, all parts in such dispenser shall be free from defects in material and workmanship. Vendor may require reasonable proof of your date of purchase from an authorized retailer or distributor. Therefore, you should retain your sales slip or invoice. The Limited Warranty shall be limited to repair or replacement of parts, which prove defective under normal use and service and which Vendor shall determine in its reasonable discretion upon examination to be defective. Before returning any parts, you should contact Vendor’s Customer Service Department using the contact information listed below. If Vendor confirms, after examination, a defect covered by this Limited Warranty in any returned part, and if Vendor approves claim, Vendor will replace such defective part without charge. If you return defective parts, transportation charges must be prepaid by you. Vendor will return replacement parts to original purchaser, freight or postage prepaid.

The Limited Warranty does not cover any failures or operating difficulties due to accident, abuse, misuse, alteration, misapplication, improper installation or improper maintenance or service by you or any third party, or failure to perform normal and routine maintenance on the dispenser, as set out in the User’s Manual. In addition, the Limited Warranty does not cover damages to the finish, such as scratches, dents, discoloration or rust after purchase.

The Limited Warranty is in lieu of all other express warranties. Vendor disclaims all warranties for products that are purchased from seller other than authorized retailers or distributors. AFTER THE PERIOD OF THE ONE (1) YEAR EXPRESS WARRANTY, VENDOR DISCLAIMS ANY AND ALL IMPLIED WARRANTIES, INCLUDING WITHOUT LIMITATION THE IMPLIED WARRANTIES OF MERCHANTABILITY AND FITNESS FOR A PARTICULAR PURPOSE. FURTHER, VENDOR SHALL HAVE NO LIABILITY WHATSOEVER TO PURCHASER OR ANY THIRD PARTY FOR ANY SPECIAL, INDIRECT, PUNITIVE, INCIDENTAL, OR CONSEQUENTIAL DAMAGES. Vendor assumes no responsibility for any defects caused by third parties. This Limited Warranty gives the purchaser specific legal rights; a purchaser may have other rights depending upon where he or she lives. Some jurisdictions do not allow exclusion or limitation of special, incidental or consequential damages, or limitations on how long a warranty lasts, so the above exclusion and limitations may not apply to you.

Warranty is void if the electrical outlet is improperly wired to incorrectly sized circuit breaker or fuse, if not grounded properly, or wires do not have correct polarity.

Use of this cooler confirms Purchasers agreement with the conditions of this warranty.

Electrotemp Technologies Inc.
406 Watline Avenue
Mississauga, Ontario, L4Z-1X2
1-844-926-6537
www.electrotemp.com

IMPORTANT: Do NOT Return Dispenser To Store.
If you have a question or problem, please contact 1-844-494-4757 for assistance.

®/™ ©2014 Whirlpool. All rights reserved.
Manufactured under license by
Electrotemp Technologies Inc., Mississauga, ON.
Limited Warranty provided by manufacturer.

File Name : Manual 8LIECH-SCSSFP5W-English

PN : 5M009983XW00

Technical requirement:

1 、 Size: 215×279mm

2 、 Single color printing

3 、 Meets ROHS requirements

4 、 Sample must be confirmed before mass production.

Do not revise drawing without authorization.

Design:_____ Audit by engineer:_____ Audit by salesman:_____

Audit by QC:_____ Approved by:_____