

Pre-Installation

SPECIFICATIONS

Free Speed (RPM)	Weight (lbs)	Length (in)	Air Cons. (SCFM)	Maximum Operating Pressure (PSI)
20,000	1.14	6.6	4	90

PACKAGE CONTENTS

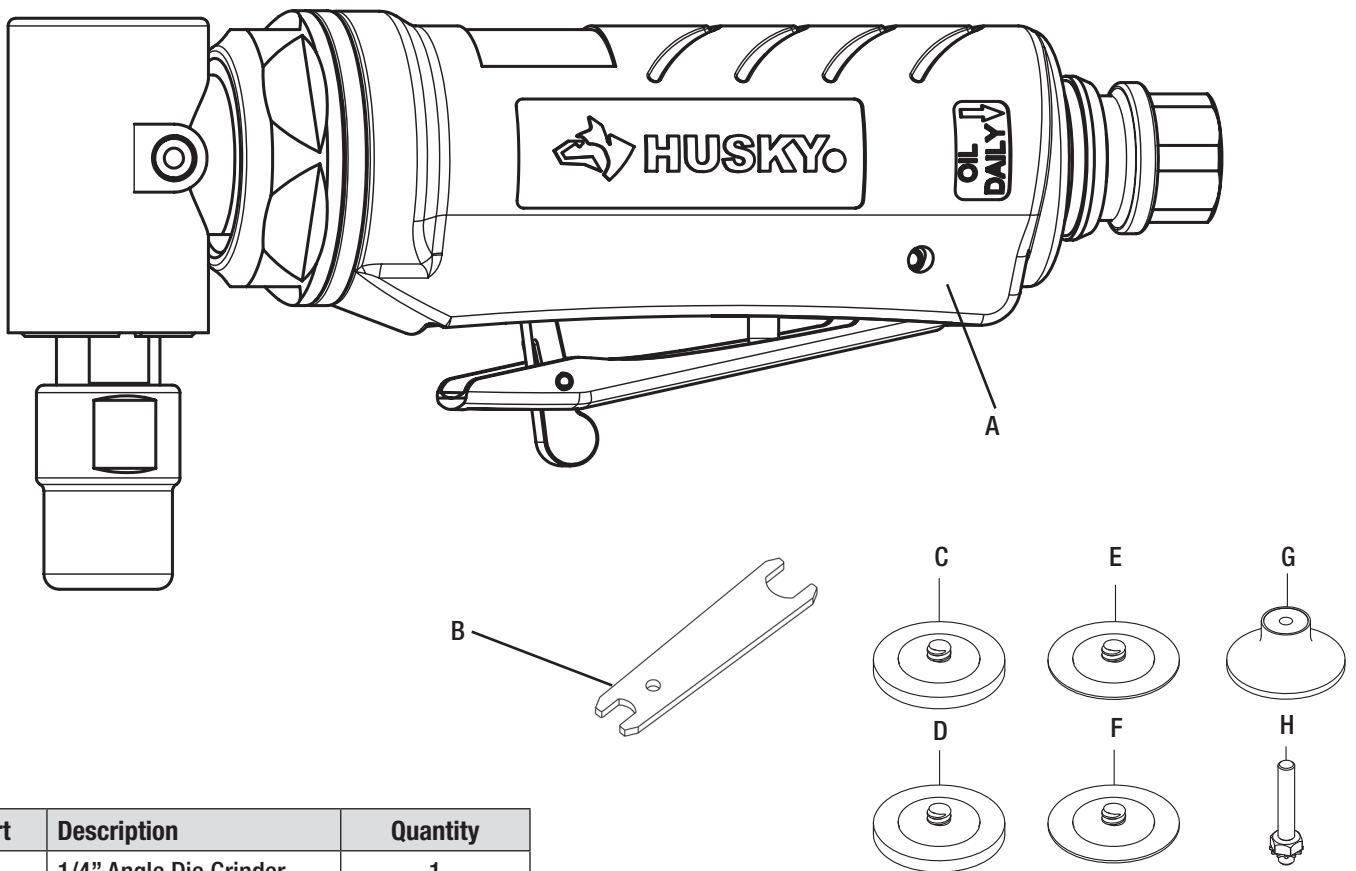

Part	Description	Quantity
A	1/4" Angle Die Grinder	1
B	Spanner Wrench	2
C	2" Fine Surface Prep	1
D	2" Medium Surface Prep	1
E	2" Grit Sanding Disc #40	1
F	2" Grit Sanding Disc #60	1
G	2" Sanding Backup Pad	1
H	Bit	1