

USE AND CARE GUIDE

AUSTIN 1-LIGHT MINI PENDANT

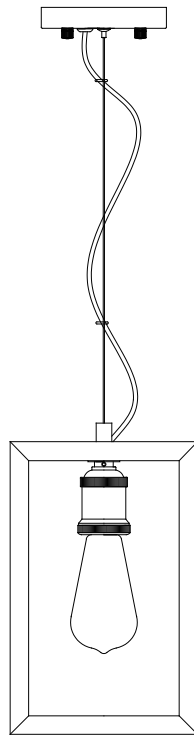

Questions, problems, missing parts? Before returning to the store,
call Fifth and Main Customer Service fifthandmainsupport@troycsf.com
8 a.m. - 6 p.m., PST, Monday - Friday

THANK YOU

We appreciate the trust and confidence you have placed in Fifth and Main Collection through the purchase of this 1 light mini pendant
We strive to continually create quality products designed to enhance your home. Thank you for choosing Fifth and Main!

Table of Contents

Table of Contents	2	Tools required	3
Safety Information	2	Hardware Included	3
Warranty	2	Package Contents	4
What is Covered	2	Installation	5
What is Not Covered	2	Care and Cleaning	7
Pre-Installation	3	Troubleshooting	7
Planning Installation	3		

Safety Information



WARNING: Carefully read and understand the information given in this manual before beginning the assembly and installation. Failure to do so could lead to electric shock, fire or other injuries which could be hazardous or even fatal.



WARNING: Be sure the electricity to the wires you are working on is shut off. Either remove the fuse or turn off the circuit breaker.

Warranty

WHAT IS COVERED

The manufacturer warrants this fixture to be free from defects in materials and workmanship for a period of five (5) years from date of purchase. This warranty applies only to original consumer purchaser and only to products used in normal use and service. If this product is found to be defective, the manufacturer's only obligation, and your exclusive remedy, is the repair or replacement of the product at the manufacturer's discretion, provided that the product has not been damaged through misuse, abuse, accident, modifications, alterations, neglect or mishandling.

WHAT IS NOT COVERED

This warranty shall not apply to any product that is found to have been improperly installed, setup, or used in any way not in accordance with the instructions supplied with the product. This warranty shall not apply to a failure of the product as a result of an accident, misuse, abuse, negligence, alteration, or faulty installation, or any other failure not relating to faulty material or workmanship. This warranty shall not apply to the finish on any portion of the product such as surface and/or weathering, as this is considered normal wear and tear. The manufacturer does not warrant and specially disclaims any warranty, whether express or implied, of fitness for a particular purpose, other than the warranty contained herein. The manufacturer specifically disclaims any liability and shall not be liable for any consequential or incidental loss or damage, including but not limited to any labor/expense costs involved in the replacement or repair of said product.

Contact the Customer Service fifthandmainsupport@troycsi.com

Pre-Installation

PLANNING INSTALLATION

Read all instructions before assembly. Before starting installation of this fixture or removal of a previous fixture, disconnect the power by turning off the circuit breaker or by removing the fuse at the fuse box. To avoid damaging this product, assemble it on a soft, non-abrasive surface such as carpet or cardboard.



NOTE: Keep your receipt and these instructions for proof of purchase.

TOOLS REQUIRED

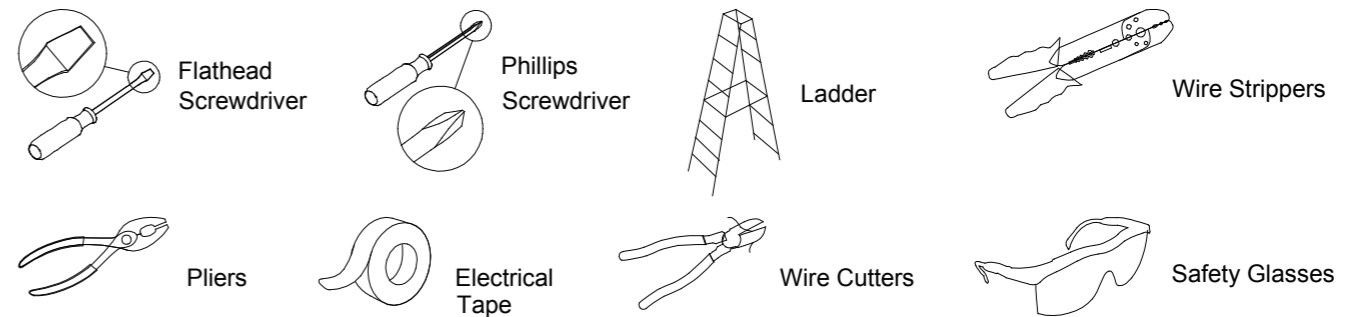

HARDWARE INCLUDED



NOTE: Hardware not shown to actual size.

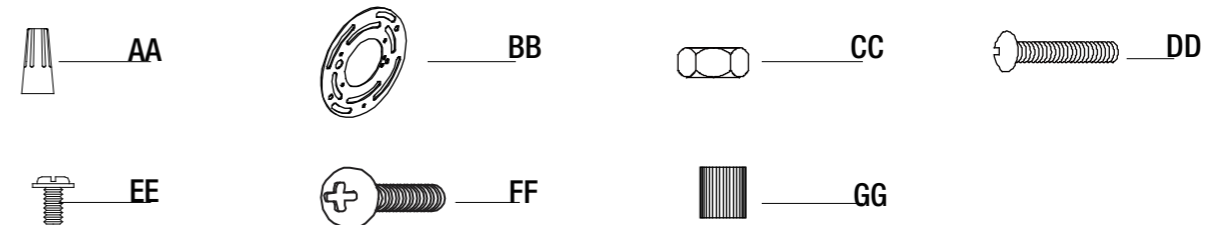

Part	Description	Quantity
AA	Wire Nut	3
BB	Mounting Plate	1
CC	Hex Nut	2
DD	Outlet Box Screw	2
EE	Green Ground Screw	1
FF	Mounting Screw	2
GG	Lock Nut	2

Pre-Installation (continued)

PACKAGE CONTENTS

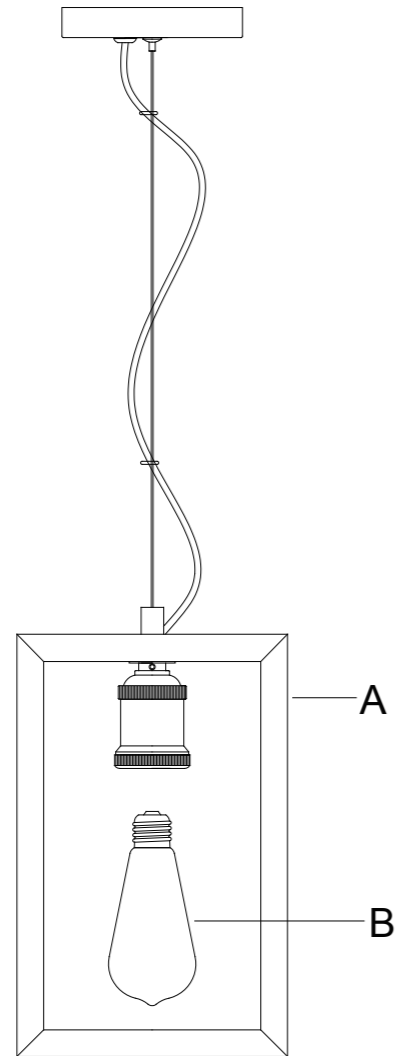

Part	Description	Quantity
A	Fixture body	1
B	ST64 bulb	1

Assembly

1 Assembling the light fixture

- To adjust the height, push in pin (1) on canopy () and slide cable (2) up or down.

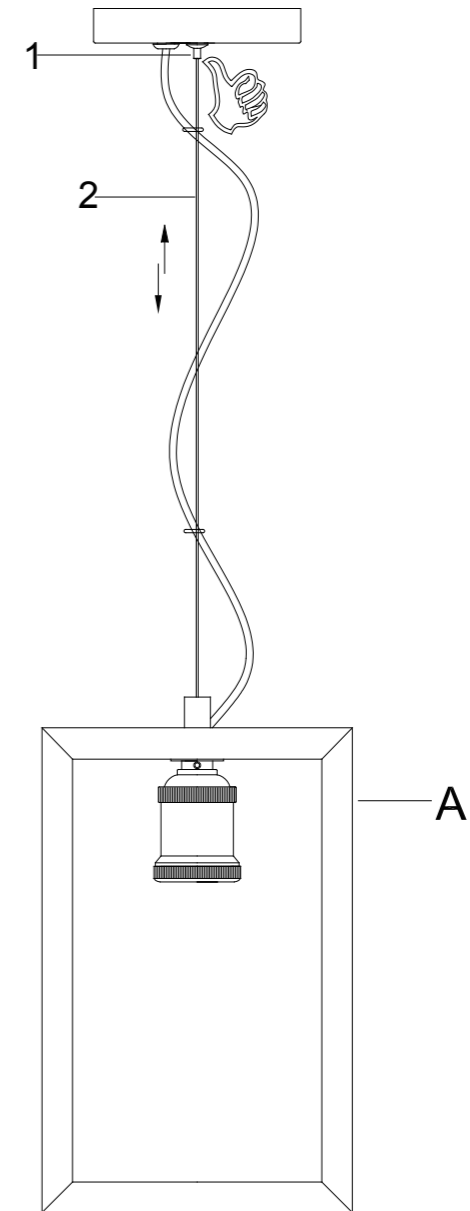

Installation

2 Installing the cross bar

- Thread the two Mounting Screws (FF) into the Mounting plate (BB), then secure with the Hex Nuts (CC).
- Attach the Mounting plate (BB) to the junction box (not included) with the two outlex Box Screws (DD) provided.

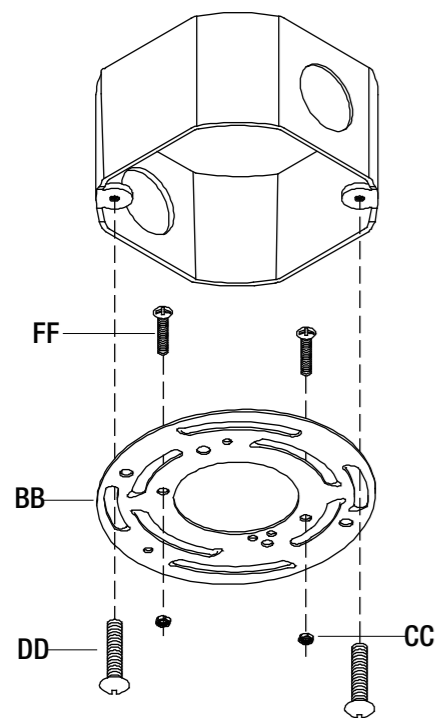

3 Making the electrical connections

NOTE: Always use Wire Nuts (AA) to connect wires and push all excess wires and connections back into the junction box.

- Connect the ground wire (bare copper or green wire) from the branch circuit to the Green Ground Screw (EE) on the Mounting Plate (BB).

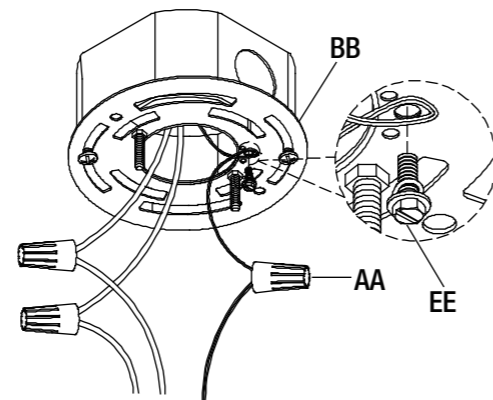

- Connect the fixture wires as follows:

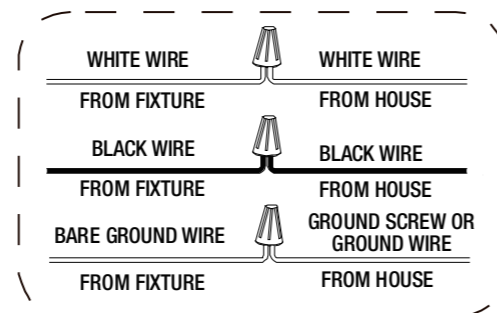

Installation (continued)

4 Installing the fixture body

- Align the mounting holes on the Fixture Body (A) with the Mounting Screws (FF) on the Mounting Plate (BB) and secure with the Lock Nuts (GG).

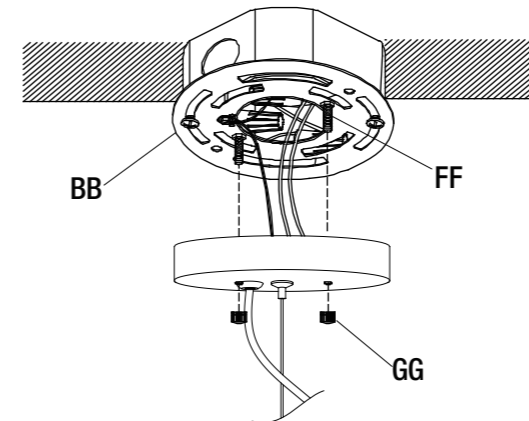

5 Install bulb

- Install bulbs(B) to socket

NOTE: Use the 60-watt max. medium-base ST64 bulbs included.

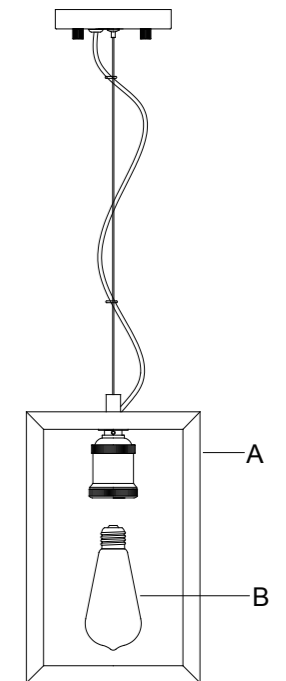

Care and cleaning

- Clean the fixture with a soft, dry cloth.
- Do not use any cleaners with chemicals, solvents or harsh abrasives.

CAUTION: Before attempting to clean the fixture, disconnect the power to the fixture by turning the breaker off or removing the fuse from the fuse box.

Troubleshooting

Problem	Possible cause	Solution
The fixture will not light.	The power is off.	Ensure the power supply is On.
	The circuit breaker is off.	Ensure the circuit breaker is in the On position.
The fuse blows or the circuit breaker trips when the light is turned on.	The wires are crossed or the power wire is grounding out.	Check the wire connections. Contact a qualified electrician or call the Customer Service Team at 1-800-533-7869 ext.4131

Fifth and Main

LIGHTING

Questions, problems, missing parts? Before returning to the store,
call Fifth and Main Customer Service fifthandmainsupport@troycsl.com
8 a.m.-6 p.m., PST, Monday-Friday

Retain this manual for future use.