



OPERATOR'S MANUAL

16 in. SCROLL SAW

VARIABLE SPEED

SC164VS

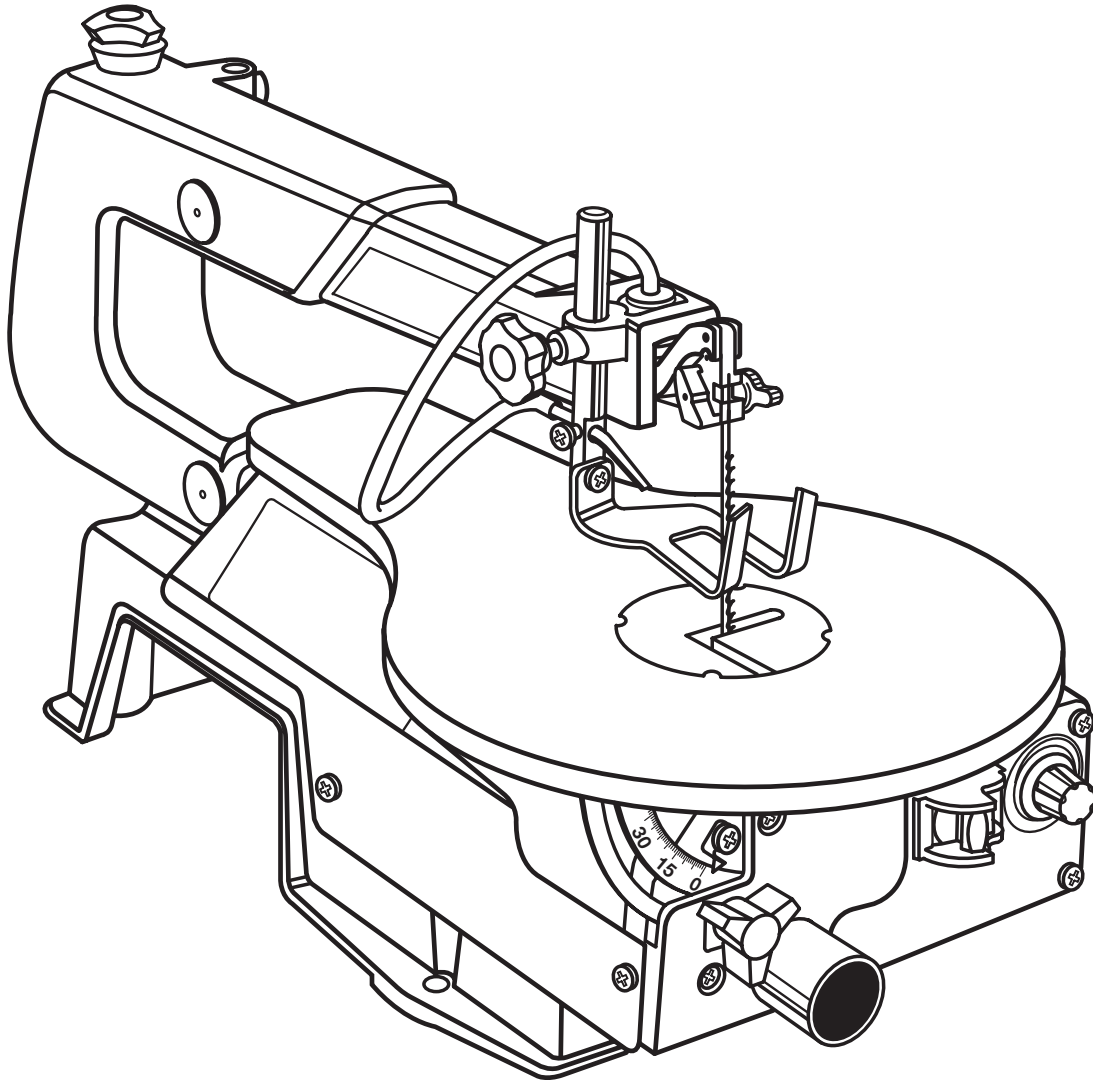

Your scroll saw has been engineered and manufactured to our high standard for dependability, ease of operation, and operator safety. When properly cared for, it will give you years of rugged, trouble-free performance.

⚠ WARNING: To reduce the risk of injury, the user must read and understand the operator's manual before using this product.

Thank you for your purchase.

SAVE THIS MANUAL FOR FUTURE REFERENCE

TABLE OF CONTENTS

■ Introduction	2
■ Warranty	2
■ General Safety Rules.....	3-4
■ Specific Safety Rules.....	4
■ Symbols.....	5-6
■ Electrical	7
■ Glossary of Terms.....	8
■ Features.....	9-10
■ Tools Needed	10
■ Loose Parts	11
■ Assembly.....	12-15
■ Operation.....	15-19
■ Maintenance.....	19-20
■ Troubleshooting.....	21
■ Parts Ordering / Service	Back Page

INTRODUCTION

This product has many features for making its use more pleasant and enjoyable. Safety, performance, and dependability have been given top priority in the design of this product making it easy to maintain and operate.

WARRANTY

RYOBI® POWER TOOL - LIMITED TWO YEAR WARRANTY AND 30 DAY EXCHANGE POLICY

One World Technologies, Inc., warrants its RYOBI® power tools with the following conditions:

30-DAY EXCHANGE POLICY: During the first 30 days after date of purchase, you may either request service under this warranty or you may exchange any RYOBI® power tool which does not work properly due to defective workmanship or materials by returning the power tool to the dealer from which it was purchased. To receive a replacement power tool or requested warranty service, you must present proof of purchase and return all original equipment packaged with the original product. The replacement power tool will be covered by the limited warranty for the balance of the two year period from the date of the original purchase.

WHAT THIS WARRANTY COVERS: This warranty covers all defects in workmanship or materials in your RYOBI® power tool for a period of two years from the date of purchase. With the exception of batteries, power tool accessories are warranted for ninety (90) days. Batteries are warranted for two years.

HOW TO GET SERVICE: Just return the power tool, properly packaged and postage prepaid, to an Authorized Service Center. You can obtain the location of the Service Center nearest you by contacting a service representative at One World Technologies, Inc., P.O. Box 1207, Anderson, SC 29622-1207, by calling 1-800-525-2579 or by logging on to www.ryobitools.com. When you request warranty service, you must also present proof of purchase documentation, which includes the date of purchase (for example, a bill of sale). We will repair any faulty workmanship, and either repair or replace any defective part, at our option. We will do so without any charge to you. We will complete the work in a reasonable time, but, in any case, within ninety (90) days or less.

WHAT'S NOT COVERED: This warranty applies only to the original purchaser at retail and may not be transferred. This warranty only covers defects arising under normal usage and does not cover any malfunction, failure or defects resulting from misuse, abuse, neglect, alteration, modification or repairs by other than Authorized Service Centers. One World Technologies, Inc. makes no warranties, representations or promises as to the quality or performance of its power tools other than those specifically stated in this warranty.

ADDITIONAL LIMITATIONS: Any implied warranties granted under state law, including warranties of merchantability or fitness for a particular purpose, are limited to two years from the date of purchase. One World Technologies, Inc. is not responsible for direct, indirect, or incidental damages, so the above limitations and exclusions may not apply to you. This warranty gives you specific legal rights, and you may also have other rights which vary from state to state.

GENERAL SAFETY RULES

WARNING:

Read and understand all instructions. Failure to follow all instructions listed below, may result in electric shock, fire and/or serious personal injury.

READ ALL INSTRUCTIONS

- **KNOW YOUR POWER TOOL.** Read the operator's manual carefully. Learn the applications and limitations as well as the specific potential hazards related to this tool.
- **GUARD AGAINST ELECTRICAL SHOCK BY PREVENTING BODY CONTACT WITH GROUNDED SURFACES.** For example: pipes, radiators, ranges, refrigerator enclosures.
- **KEEP GUARDS IN PLACE** and in good working order.
- **REMOVE ADJUSTING KEYS AND WRENCHES.** Form habit of checking to see that keys and adjusting wrenches are removed from tool before turning it on.
- **KEEP WORK AREA CLEAN.** Cluttered areas and benches invite accidents. **DO NOT** leave tools or pieces of wood on the tool while it is in operation.
- **DO NOT USE IN DANGEROUS ENVIRONMENTS.** Do not use power tools in damp or wet locations or expose to rain. Keep the work area well lit.
- **KEEP CHILDREN AND VISITORS AWAY.** All visitors should wear safety glasses and be kept a safe distance from work area. Do not let visitors contact tool or extension cord while operating.
- **MAKE WORKSHOP CHILDPROOF** with padlocks, master switches, or by removing starter keys.
- **DON'T FORCE THE TOOL.** It will do the job better and safer at the feed rate for which it was designed.
- **USE THE RIGHT TOOL.** Do not force the tool or attachment to do a job for which it was not designed.
- **USE THE PROPER EXTENSION CORD.** Make sure your extension cord is in good condition. Use only a cord heavy enough to carry the current your product will draw. An undersized cord will cause a drop in line voltage resulting in loss of power and overheating. A wire gauge size (A.W.G.) of at least **16** is recommended for an extension cord 25 feet or less in length. If in doubt, use the next heavier gauge. The smaller the gauge number, the heavier the cord.
- **DRESS PROPERLY.** Do not wear loose clothing, neckties, or jewelry that can get caught and draw you into moving parts. Rubber gloves and nonskid footwear are recommended when working outdoors. Also wear protective hair covering to contain long hair.
- **ALWAYS WEAR SAFETY GLASSES WITH SIDE SHIELDS.** Everyday eyeglasses have only impact-resistant lenses, they are **NOT** safety glasses.
- **SECURE WORK.** Use clamps or a vise to hold work when practical, it is safer than using your hand and frees both hands to operate the tool.
- **DO NOT OVERREACH.** Keep proper footing and balance at all times.
- **MAINTAIN TOOLS WITH CARE.** Keep tools sharp and clean for better and safer performance. Follow instructions for lubricating and changing accessories.
- **DISCONNECT TOOLS.** When not in use, before servicing, or when changing attachments, blades, bits, cutters, etc., all tools should be disconnected from power source.
- **AVOID ACCIDENTAL STARTING.** Be sure switch is off when plugging in any tool.
- **USE RECOMMENDED ACCESSORIES.** Consult the operator's manual for recommended accessories. The use of improper accessories may result in injury.
- **NEVER STAND ON TOOL.** Serious injury could occur if the tool is tipped.
- **CHECK DAMAGED PARTS.** Before further use of the tool, a guard or other part that is damaged should be carefully checked to determine that it will operate properly and perform its intended function. Check for alignment of moving parts, binding of moving parts, breakage of parts, mounting and any other conditions that may affect its operation. A guard or other part that is damaged must be properly repaired or replaced by an authorized service center to avoid risk of personal injury.
- **USE THE RIGHT DIRECTION OF FEED.** Feed work into a blade, cutter, or sanding spindle against the direction or rotation of the blade, cutter, or sanding spindle only.
- **NEVER LEAVE TOOL RUNNING UNATTENDED. TURN THE POWER OFF.** Don't leave tool until it comes to a complete stop.
- **PROTECT YOUR LUNGS.** Wear a face or dust mask if the cutting operation is dusty.
- **PROTECT YOUR HEARING.** Wear hearing protection during extended periods of operation.
- **DO NOT ABUSE CORD.** Never carry tool by the cord or yank it to disconnect from receptacle. Keep cord from heat, oil, and sharp edges.
- **USE OUTDOOR EXTENSION CORDS.** When tool is used outdoors, use only extension cords with approved ground connection that are intended for use outdoors and so marked.
- **KEEP BLADES CLEAN, SHARP, AND WITH SUFFICIENT SET.** Sharp blades minimize stalling and kickback.
- **BLADE COASTS AFTER BEING TURNED OFF.**
- **NEVER USE IN AN EXPLOSIVE ATMOSPHERE.** Normal sparking of the motor could ignite fumes.
- **INSPECT TOOL CORDS PERIODICALLY.** If damaged, have repaired by a qualified service technician at an authorized service facility. The conductor with insulation having an outer surface that is green with or without yellow stripes is the equipment-grounding conductor. If repair or replacement of the electric cord or plug is necessary, do not connect the equipment-grounding conductor to a live terminal. Repair or replace a damaged or worn cord immediately. Stay constantly aware of cord location and keep it well away from the rotating blade.

GENERAL SAFETY RULES







- **INSPECT EXTENSION CORDS PERIODICALLY** and replace if damaged.
- **GROUND ALL TOOLS.** If tool is equipped with three-prong plug, it should be plugged into a three-hole electrical receptacle.
- **CHECK WITH A QUALIFIED ELECTRICIAN** or service personnel if the grounding instructions are not completely understood or if in doubt as to whether the tool is properly grounded.
- **USE ONLY CORRECT ELECTRICAL DEVICES:** 3-wire extension cords that have 3-prong grounding plugs and 3-pole receptacles that accept the tool's plug.
- **DO NOT MODIFY** the plug provided. If it will not fit the outlet, have the proper outlet installed by a qualified electrician.
- **KEEP TOOL DRY, CLEAN, AND FREE FROM OIL AND GREASE.** Always use a clean cloth when cleaning. Never use brake fluids, gasoline, petroleum-based products, or any solvents to clean tool.
- **STAY ALERT AND EXERCISE CONTROL.** Watch what you are doing and use common sense. Do not operate tool when you are tired. Do not rush.
- **DO NOT USE TOOL IF SWITCH DOES NOT TURN IT ON AND OFF.** Have defective switches replaced by an authorized service center.
- **USE ONLY CORRECT BLADES.**
- **BEFORE MAKING A CUT, BE SURE ALL ADJUSTMENTS ARE SECURE.**
- **BE SURE BLADE PATH IS FREE OF NAILS.** Inspect for and remove all nails from lumber before cutting.
- **NEVER TOUCH BLADE** or other moving parts during use.
- **NEVER START A TOOL WHEN ANY ROTATING COMPONENT IS IN CONTACT WITH THE WORKPIECE.**
- **DO NOT OPERATE A TOOL WHILE UNDER THE INFLUENCE OF DRUGS, ALCOHOL, OR ANY MEDICATION.**
- **WHEN SERVICING** use only identical replacement parts. Use of any other parts may create a hazard or cause product damage.
- **USE ONLY RECOMMENDED ACCESSORIES** listed in this manual or addendums. Use of accessories that are not listed may cause the risk of personal injury. Instructions for safe use of accessories are included with the accessory.
- **DOUBLE CHECK ALL SETUPS.** Make sure blade is tight and not making contact with saw or workpiece before connecting to power supply.

SPECIFIC SAFETY RULES

- **FIRMLY CLAMP OR BOLT** the tool to a workbench or table at approximately hip height.
- **KEEP HANDS AWAY FROM CUTTING AREA.** Do not reach underneath work or in blade cutting path with hands and fingers for any reason. Always turn the power off.
- **ALWAYS USE A CLAMP** to secure the workpiece when possible.
- **BE SURE THE BLADE CLEARS THE WORKPIECE.** Never start the saw with the blade touching the workpiece. Allow motor to come up to full speed before starting cut.
- **MAKE SURE THE WORK AREA HAS AMPLE LIGHTING** to see the work and that no obstructions will interfere with safe operation **BEFORE** performing any work using the saw.
- **ALWAYS TURN OFF THE SAW** before disconnecting it to avoid accidental starting when reconnecting to power supply. **NEVER** leave the saw unattended while connected to a power source.
- **TURN OFF TOOL** and wait for saw blade to come to a complete stop before moving workpiece or changing settings.
- **THIS TOOL** should have the following markings:
 - a) Wear eye protection.
 - b) Keep hands out of path of saw blade
 - c) Do not operate saw without guards in place.
 - d) Do not perform any operation freehand.
 - e) Never reach around saw blade.
 - f) Turn off tool and wait for saw blade to stop before moving workpiece or changing settings.
 - g) Disconnect power (or unplug tool as applicable) before changing blade or servicing.
 - h) No load speed.
- **ALWAYS** carry the tool only by the carrying handle.
- **IF THE POWER SUPPLY CORD IS DAMAGED**, it must be replaced only by the manufacturer or by an authorized service center to avoid risk.
- **SAVE THESE INSTRUCTIONS.** Refer to them frequently and use them to instruct other users. If you loan someone this tool, loan them these instructions also.



SYMBOLS

Some of the following symbols may be used on this tool. Please study them and learn their meaning. Proper interpretation of these symbols will allow you to operate the tool better and safer.

SYMBOL	NAME	DESIGNATION/EXPLANATION
V	Volts	Voltage
A	Amperes	Current
Hz	Hertz	Frequency (cycles per second)
W	Watt	Power
min	Minutes	Time
~	Alternating Current	Type of current
≡	Direct Current	Type or a characteristic of current
n_0	No Load Speed	Rotational speed, at no load
	Class II Construction	Double-insulated construction
.../min	Per Minute	Revolutions, strokes, surface speed, orbits etc., per minute
	Wet Conditions Alert	Do not expose to rain or use in damp locations.
	Read The Operator's Manual	To reduce the risk of injury, user must read and understand operator's manual before using this product.
	Eye Protection	Always wear safety goggles or safety glasses with side shields and, as necessary, a full face shield when operating this product.
	Safety Alert	Precautions that involve your safety.
	No Hands Symbol	Failure to keep your hands away from the blade will result in serious personal injury.
	Hot Surface	To reduce the risk of injury or damage, avoid contact with any hot surface.

SYMBOLS

The following signal words and meanings are intended to explain the levels of risk associated with this product.

SYMBOL	SIGNAL	MEANING
	DANGER:	Indicates an imminently hazardous situation, which, if not avoided, will result in death or serious injury.
	WARNING:	Indicates a potentially hazardous situation, which, if not avoided, could result in death or serious injury.
	CAUTION:	Indicates a potentially hazardous situation, which, if not avoided, may result in minor or moderate injury.
	CAUTION:	(Without Safety Alert Symbol) Indicates a situation that may result in property damage.

SERVICE

Servicing requires extreme care and knowledge and should be performed only by a qualified service technician. For service we suggest you return the product to the nearest **AUTHORIZED SERVICE CENTER** for repair. When servicing, use only identical replacement parts.

WARNING:

To avoid serious personal injury, do not attempt to use this product until you read thoroughly and understand completely the operator's manual. If you do not understand the warnings and instructions in the operator's manual, do not use this product. Call Ryobi customer service for assistance.

WARNING:



The operation of any power tool can result in foreign objects being thrown into your eyes, which can result in severe eye damage. Before beginning power tool operation, always wear safety goggles or safety glasses with side shields and, when needed, a full face shield. We recommend Wide Vision Safety Mask for use over eyeglasses or standard safety glasses with side shields. Always use eye protection which is marked to comply with ANSI Z87.1.

SAVE THESE INSTRUCTIONS

ELECTRICAL

EXTENSION CORDS

Use only 3-wire extension cords that have 3-prong grounding plugs and 3-pole receptacles that accept the product's plug. When using a power product at a considerable distance from the power source, use an extension cord heavy enough to carry the current that the product will draw. An undersized extension cord will cause a drop in line voltage, resulting in a loss of power and causing the motor to overheat. Use the chart provided below to determine the minimum wire size required in an extension cord. Only round jacketed cords listed by Underwriter's Laboratories (UL) should be used.

**Ampere rating (on tool data plate)

Cord Length	Wire Size (A.W.G.)					
	0-2.0	2.1-3.4	3.5-5.0	5.1-7.0	7.1-12.0	12.1-16.0
25'	16	16	16	16	14	14
50'	16	16	16	14	14	12
100'	16	16	14	12	10	—

**Used on 12 gauge - 20 amp circuit.

NOTE: AWG = American Wire Gauge

When working with the product outdoors, use an extension cord that is designed for outside use. This is indicated by the letters "WA" on the cord's jacket.

Before using an extension cord, inspect it for loose or exposed wires and cut or worn insulation.

⚠ WARNING:

Keep the extension cord clear of the working area. Position the cord so that it will not get caught on lumber, products or other obstructions while you are working with a power product. Failure to do so can result in serious personal injury.

⚠ WARNING:

Check extension cords before each use. If damaged replace immediately. Never use product with a damaged cord since touching the damaged area could cause electrical shock resulting in serious injury.

ELECTRICAL CONNECTION

This product is powered by a precision built electric motor. It should be connected to a **power supply that is 120 volts, 60 Hz, AC only (normal household current)**. Do not operate this product on direct current (DC). A substantial voltage drop will cause a loss of power and the motor will overheat. If the saw does not operate when plugged into an outlet, double check the power supply.

SPEED AND WIRING

The no-load speed of this product is approximately 1,600 r/min. (RPM. This speed is not constant and decreases under a load or with lower voltage. For voltage, the wiring in a shop is as important as the motor's horsepower rating. A line intended only for lights cannot properly carry a power product motor. Wire that is heavy enough for a short distance will be too light for a greater distance. A line that can support one power product may not be able to support two or three products.

GROUNDING INSTRUCTIONS

In the event of a malfunction or breakdown, grounding provides a path of least resistance for electric current to reduce the risk of electric shock. This product is equipped with an electric cord having an equipment-grounding conductor and a grounding plug. The plug must be plugged into a matching outlet that is properly installed and grounded in accordance with all local codes and ordinances.

Do not modify the plug provided. If it will not fit the outlet, have the proper outlet installed by a qualified electrician. Improper connection of the equipment-grounding conductor can result in a risk of electric shock. The conductor with insulation having an outer surface that is green with or without yellow stripes is the equipment-grounding conductor. If repair or replacement of the electric cord or plug is necessary, do not connect the equipment-grounding conductor to a live terminal.

Check with a qualified electrician or service personnel if the grounding instructions are not completely understood, or if in doubt as to whether the product is properly grounded.

Repair or replace a damaged or worn cord immediately.

This product is intended for use on a circuit that has an outlet like the one shown in figure 1. It also has a grounding pin like the one shown.

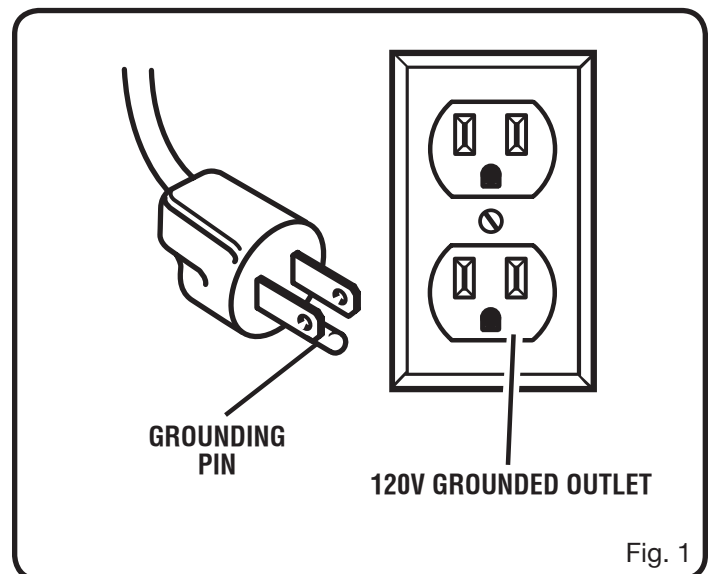

Fig. 1

GLOSSARY OF TERMS

Anti-Kickback Pawls (radial arm and table saws)

A device which, when properly installed and maintained, is designed to stop the workpiece from being kicked back toward the front of the saw during a ripping operation.

Arbor

The shaft on which a blade or cutting tool is mounted.

Bevel Cut

A cutting operation made with the blade at any angle other than 90° to the table surface.

Chamfer

A cut removing a wedge from a block so the end (or part of the end) is angled rather than at 90°.

Compound Cut

A cross cut made with both a miter and a bevel angle.

Cross Cut

A cutting or shaping operation made across the grain or the width of the workpiece.

Cutterhead (planers and jointer planers)

A rotating cutterhead with adjustable blades or knives. The blades or knives remove material from the workpiece.

Dado Cut

A non-through cut which produces a square-sided notch or trough in the workpiece (requires a special blade).

Featherboard

A device used to help control the workpiece by guiding it securely against the table or fence during any ripping operation.

FPM or SPM

Feet per minute (or strokes per minute), used in reference to blade movement.

Freehand

Performing a cut without the workpiece being guided by a fence, miter gauge, or other aids.

Gum

A sticky, sap-based residue from wood products.

Heel

Alignment of the blade to the fence.

Kerf

The material removed by the blade in a through cut or the slot produced by the blade in a non-through or partial cut.

Kickback

A hazard that can occur when the blade binds or stalls, throwing the workpiece back toward operator.

Leading End

The end of the workpiece pushed into the tool first.

Miter Cut

A cutting operation made with the workpiece at any angle to the blade other than 90°.

Non-Through Cuts

Any cutting operation where the blade does not extend completely through the thickness of the workpiece.

Push Blocks (for jointer planers)

Device used to feed the workpiece over the jointer planer cutterhead during any operation. This aid helps keep the operator's hands well away from the cutterhead.

Push Blocks and Push Sticks (for table saws)

Devices used to feed the workpiece through the saw blade during cutting operations. A push stick (not a push block) should be used for narrow ripping operations. These aids help keep the operator's hands well away from the blade.

Pilot Hole (drill presses)

A small hole drilled in a workpiece that serves as a guide for drilling large holes accurately.

Resaw

A cutting operation to reduce the thickness of the workpiece to make thinner pieces.

Resin

A sticky, sap-based substance that has hardened.

Revolutions Per Minute (RPM)

The number of turns completed by a spinning object in one minute.

Ripping or Rip Cut

A cutting operation along the length of the workpiece.

Riving Knife/Spreader/Splitter (table saws)

A metal piece, slightly thinner than the blade, which helps keep the kerf open and also helps to prevent kickback.

Saw Blade Path

The area over, under, behind, or in front of the blade. As it applies to the workpiece, that area which will be or has been cut by the blade.

Set

The distance that the tip of the saw blade tooth is bent (or set) outward from the face of the blade.

Snipe (planers)

Depression made at either end of a workpiece by cutter blades when the workpiece is not properly supported.

Through Sawing

Any cutting operation where the blade extends completely through the thickness of the workpiece.

Throw-Back

The throwing back of a workpiece usually caused by the workpiece being dropped into the blade or being placed inadvertently in contact with the blade.

Workpiece or Material

The item on which the operation is being done.

Worktable

Surface where the workpiece rests while performing a cutting, drilling, planing, or sanding operation.

FEATURES

PRODUCT SPECIFICATIONS

Throat 16 in.
Blade Length 5 in., pin or plain
Input 120 V, 60 Hz, AC Only, 1.2 A

No Load Speed 400-1,600 r/min. (SPM)
Net Weight 28 lbs.

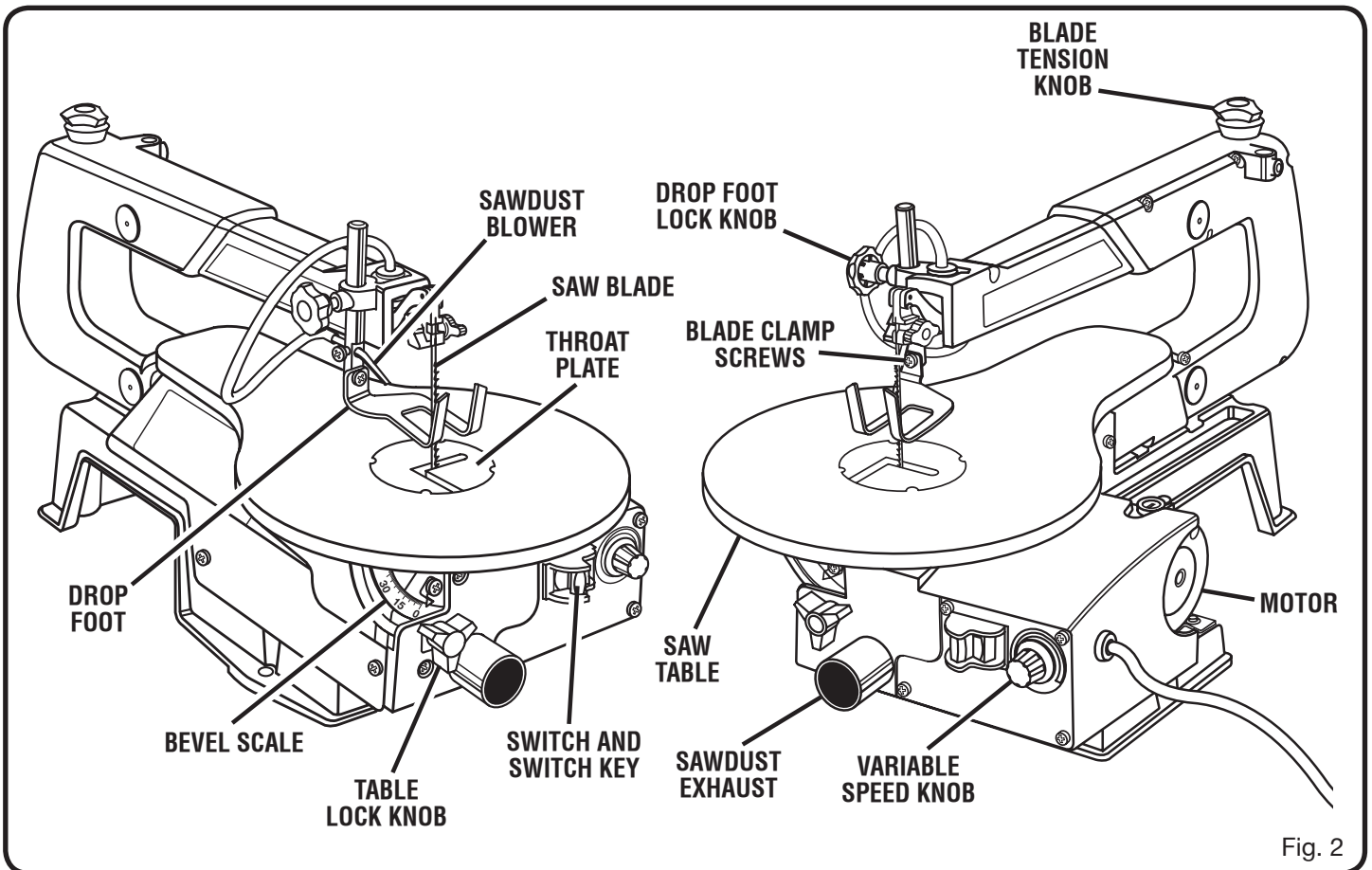

Fig. 2

FEATURES

KNOW YOUR SCROLL SAW

See Figure 2.

The safe use of this product requires an understanding of the information on the product and in this operator's manual as well as a knowledge of the project you are attempting. Before use of this product, familiarize yourself with all operating features and safety rules.

BEVEL SCALE

The bevel scale and indicator show you the degree the saw table is tilted.

BLADE CLAMP SCREWS

Blade clamp screws are used when changing saw blades.

BLADE TENSION KNOB

Loosen or tighten the blade tension by turning the blade tension knob.

DROP FOOT

This foot should always be lowered until it just rests on top of the workpiece to prevent the workpiece from lifting, yet not so much that the workpiece drags.

DROP FOOT LOCK KNOB

Allows you to raise or lower the drop foot and lock it in place.

SAWDUST BLOWER

Keeps the line of cut on the workpiece clean for more accurate scroll cuts. For best results, always direct air flow at the blade and the workpiece.

SAWDUST EXHAUST

This feature allows you to attach any 1-1/4 in. (32 mm) vacuum hose for easy sawdust collection.

SAW TABLE WITH THROAT PLATE

Your scroll saw has an aluminum saw table with tilt control for maximum accuracy. The throat plate, inserted in the saw table, allows for blade clearance.

SWITCH AND SWITCH KEY

Your scroll saw has an easy access power switch. To lock in the **OFF** position, remove the yellow switch key. Place the key in a location inaccessible to children and others not qualified to use the tool.

TABLE LOCK KNOB

Allows you to tilt the table and lock it at the desired angle up to 45°.

VARIABLE SPEED KNOB

Turn the knob to adjust the speed from the high speed of approximately 1,600 r/min. (RPM) to the low speed of approximately 400 r/min. (RPM).

TOOLS NEEDED

The following tools (not included) are needed for assembly and alignment:

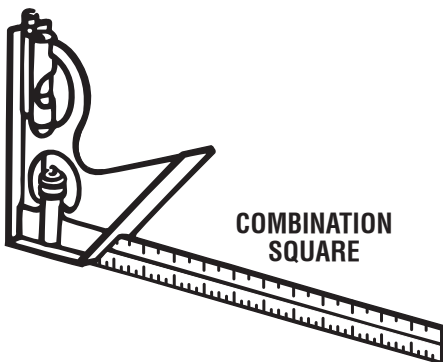

COMBINATION SQUARE



PHILLIPS SCREWDRIVER



SLOTTED SCREWDRIVER

Fig. 3

LOOSE PARTS

- 3 mm T-Handle Hex Key
- 4 mm Hex Key
- Blade(s)
- Plastic Tubing

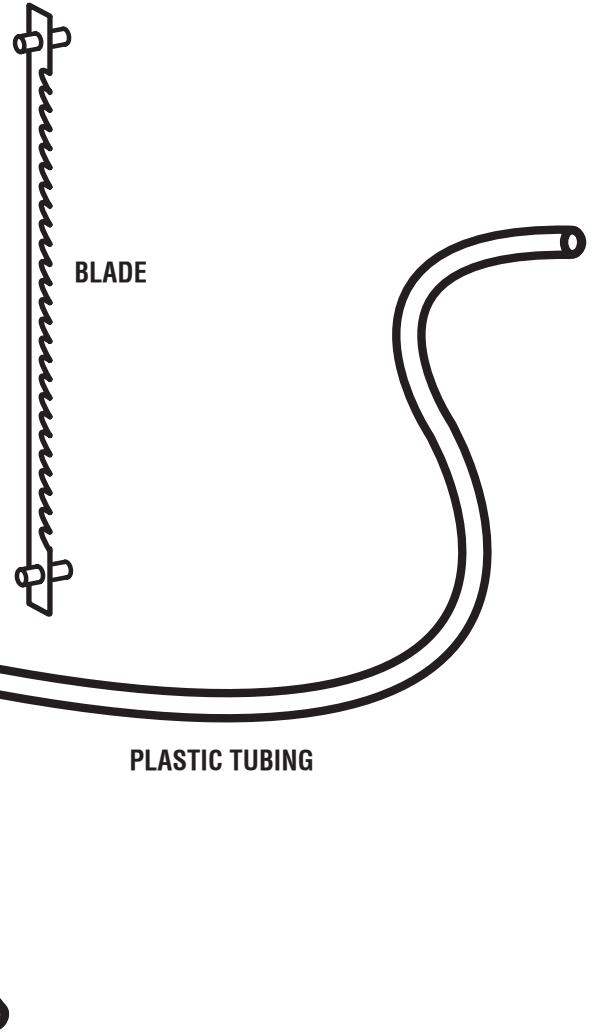
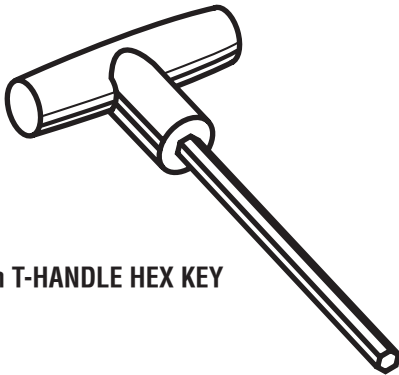
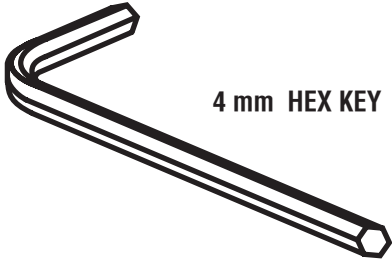

Fig. 4

⚠ WARNING:

The use of attachments or accessories not listed might be hazardous and could cause serious personal injury.

ASSEMBLY

UNPACKING

This product requires assembly.

- Carefully remove the product and any accessories from the box. Place it on a level work surface.
- Inspect the product carefully to make sure no breakage or damage occurred during shipping.
- Do not discard the packing material until you have carefully inspected the product, identified all loose parts, and satisfactorily operated the product.
- If any parts are damaged or missing, please call 1-800-525-2579 for assistance.

WARNING:

If any parts are damaged or missing, do not operate this product until the parts are replaced. Failure to heed this warning could result in possible serious personal injury.

WARNING:

Do not attempt to modify this product or create accessories not recommended for use with this product. Any such alteration or modification is misuse and could result in a hazardous condition leading to possible serious personal injury.

WARNING:

Do not connect to power supply until assembly is complete. Failure to comply could result in accidental starting and possible serious personal injury.

WARNING:

To avoid serious personal injury, always make sure the saw is securely mounted to a workbench or an approved leg stand. NEVER operate the saw on the floor.

REDUCING NOISE AND VIBRATION

You may wish to place a foam pad or piece of carpet between the saw base and the workbench to help reduce noise and vibration.

If a foam pad or piece of carpet is used, do not overtighten the mounting bolts. Leave some cushion between the padding and the saw base to help absorb the noise and vibration.

The size of the padding material should be approximately 24 in. x 12 in. x 1/2 in.

MOUNTING SCROLL SAW TO WORKBENCH

If the scroll saw is to be used in a permanent application, we recommend that you secure it in a permanent location such as a workbench. When mounting the saw to a workbench, holes should be drilled through the supporting surface of the workbench.

Each hole in the base of the saw should be bolted securely using machine bolts, washers, and nuts (not included). Bolts should be of sufficient length to accommodate the saw base, washers, nuts, and the thickness of the workbench.

- Place scroll saw on workbench. Using the saw base as a pattern, locate and mark the holes where the scroll saw is to be mounted.
- Drill four holes through the workbench.
- Place scroll saw on workbench aligning holes in the saw base with the holes drilled in the workbench.
- Insert all four bolts (not included) and tighten securely with washers and nuts (not included).

NOTE: All bolts should be inserted from the top. Install the washers and nuts from the underside of the bench.

Supporting surface where scroll saw is mounted should be examined carefully after mounting to insure that no movement during use can result. If any tipping or walking is noted, secure workbench or supporting surface before beginning cutting operations.

ASSEMBLY

CLAMPING SCROLL SAW TO WORKBENCH

See Figure 5.

If the scroll saw is to be used in a portable application, it is recommended that you fasten it permanently to a mounting board that can easily be clamped to a workbench or other supporting surface. The mounting board should be of sufficient size to avoid tipping of saw while in use. Any good grade plywood or chipboard with a 3/4 in. thickness is recommended.

- Mount saw to board using holes in saw base as a template for hole pattern. Locate and mark the holes where scroll saw is to be mounted.
- Follow last three steps in previous section called **Mounting Scroll Saw to Workbench.**

If lag bolts are being used, make sure they are long enough to go through holes in the saw base and the material the saw is being mounted to.

If machine bolts are being used, make sure they are long enough to go through holes in the saw base, the material the saw is being mounted to, and the washers and nuts.

NOTE: It may be necessary to countersink washers and nuts on the bottom side of mounting board.

SAWDUST BLOWER

See Figure 6.

The sawdust blower is designed and preset to direct air to the most effective point on the cutting line. Be sure drop foot is properly adjusted to secure workpiece and direct air to the cutting surface.

- Plastic tubing should be connected to the bellows tube before starting the saw.

DROP FOOT

See Figure 6.

To prevent workpiece from lifting, the drop foot should be adjusted so it just rests on the top of the workpiece. The drop foot should not be adjusted so that the workpiece drags. Always retighten the drop foot lock knob after each adjustment has been made.

- Loosen the drop foot lock knob.
- Lower or raise the drop foot to the desired position.
- Retighten the drop foot lock knob.

The tall, front part of the drop foot acts as a blade guard to prevent accidental contact with the blade.

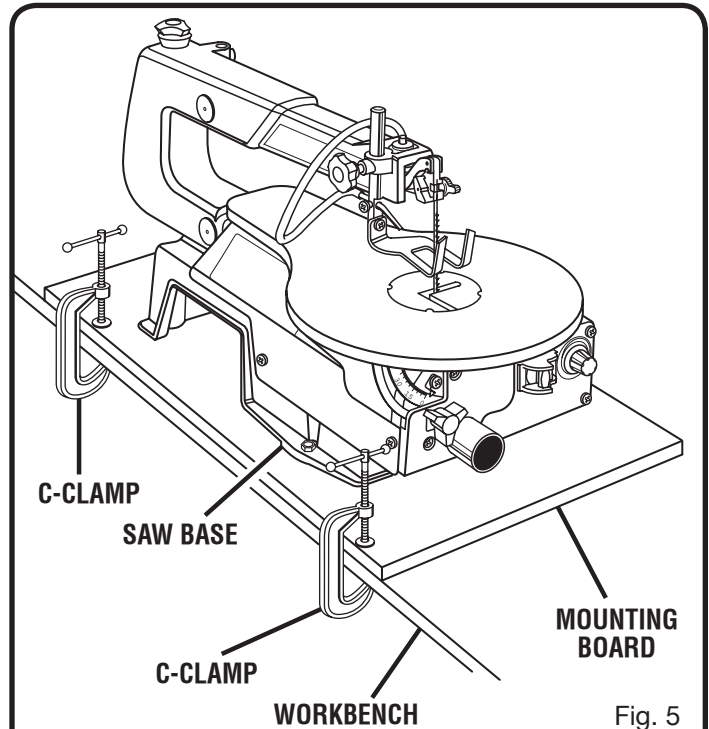

Fig. 5

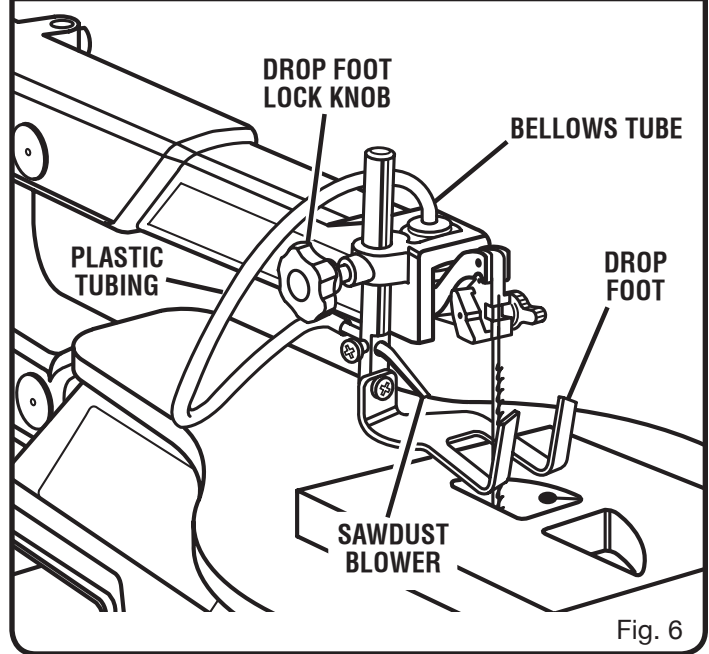

Fig. 6

