

ASSEMBLY INSTRUCTIONS

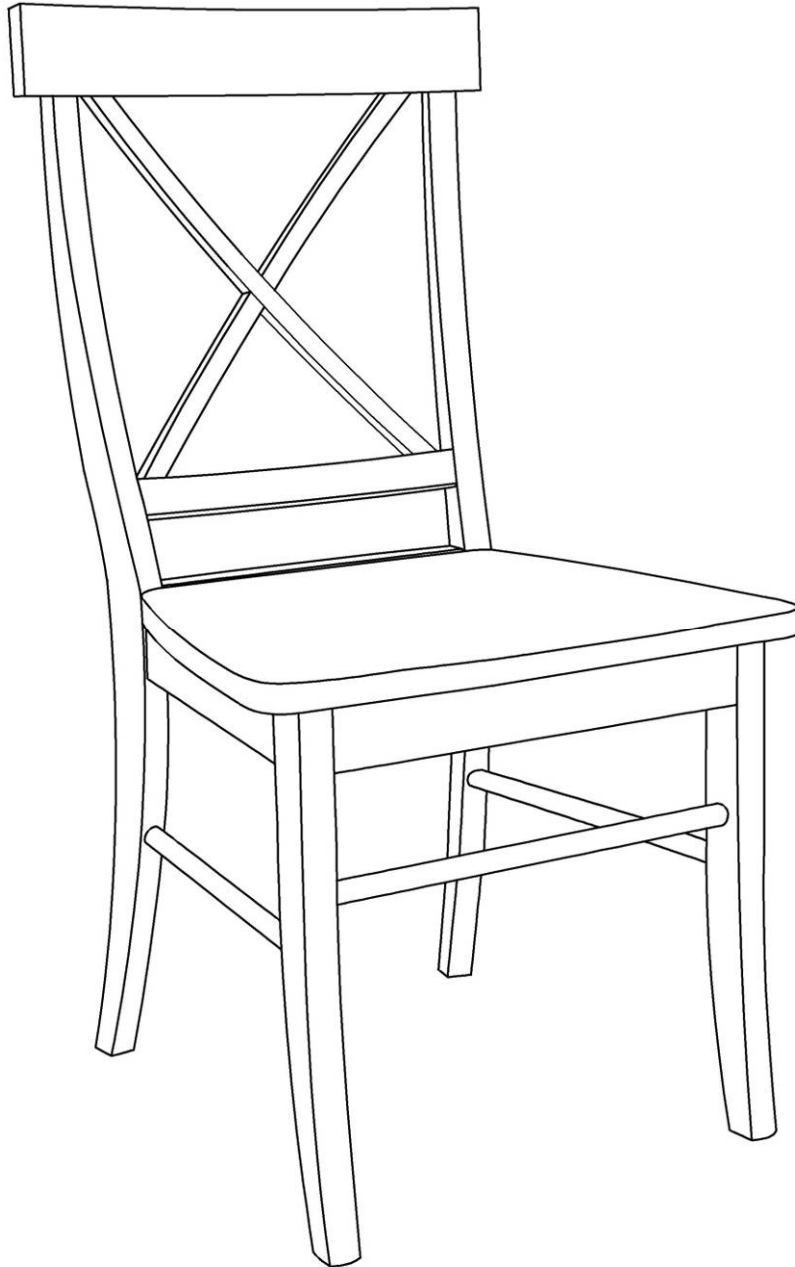

Description : X-BACK CHAIR
Item No. : C-613

BEFORE ASSEMBLY

Thank you for purchasing this quality product. This product has been designed for easy assembly and constructed for durability. Please take the time to read and follow the assembly instructions carefully.

Be sure to check all packing material carefully for small parts which may have come loose inside the carton during shipment. Please separate, identify, and count all parts and metal hardware. Compare with part list to be sure all parts are present. If hardware is missing or you have difficulty assembling this product, please call Toll Free: 1-888-944-8396.



IMPORTANT NOTE:

- Place all wooden parts on a clean and smooth surface such as a rug or carpet to avoid the parts from being scratched.
- Remove all wrapping material, including staples & packing straps before you start to assemble.
- DO NOT tighten all screws and bolts until completely assembled.
- Keep all hardware parts out of reach of children.

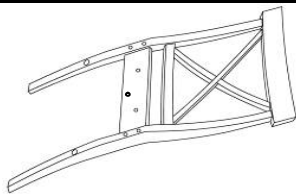
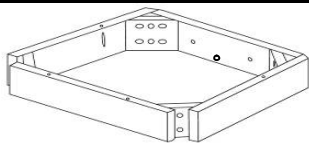

PART LIST

When unpacking, please be careful not to discard any parts with the packaging. Before continuing, please make sure you have the following parts:

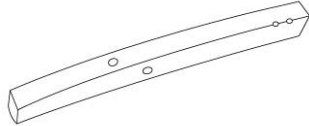
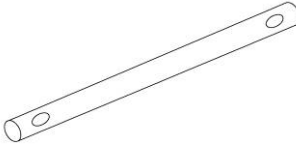
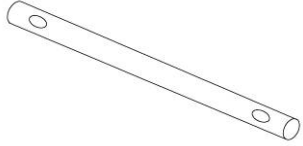
NO	Description	Qty	Sketch	NO	Description	Qty	Sketch
A	Back	1		B	Seat Frame	1	
C	Seat	1		D	Front Leg (L-R)	2	
E	Side Stretcher	2		F	Front stretcher	1	

HARDWARE LIST

When unpacking, please be careful not to discard any parts with the packaging. Before continuing, please make sure you have all of the following hardware:

NO	Description	Qty	Sketch	NO	Description	Qty	Sketch
1	Short bolt (M6x40mm)	3		2	Medium bolt (M6x60mm)	4	
3	Long bolt (M6x80mm)	4		4	Screw (M4x35mm)	10	
5	Flat washer (Φ6.5x 19mm)	11		6	Lock washer (Φ6.5x 11mm)	11	
7	Allen key (4mm)	1					

STEP 1

Attach seat frame (B) to the back (A) with bolts (1) and (3), and washers (5) and (6), tighten with Allen key (7) as shown below.

Note: DO NOT tighten any of the bolts, until the chair is assembled, then put on a flat level surface to make sure the chair is level and then tighten the bolts.

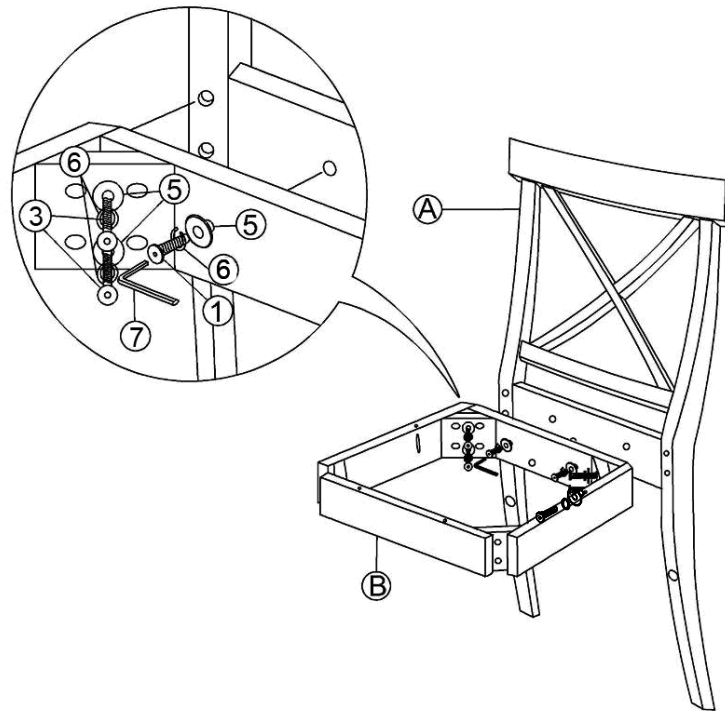

STEP 2

Attach front legs (D) to the seat frame with bolts (2), washers (5) and (6). Tighten with Allen key (7). Attach front stretcher (F) between front legs and side stretchers (E) to front and back legs with screws (4). Tighten with a screwdriver.

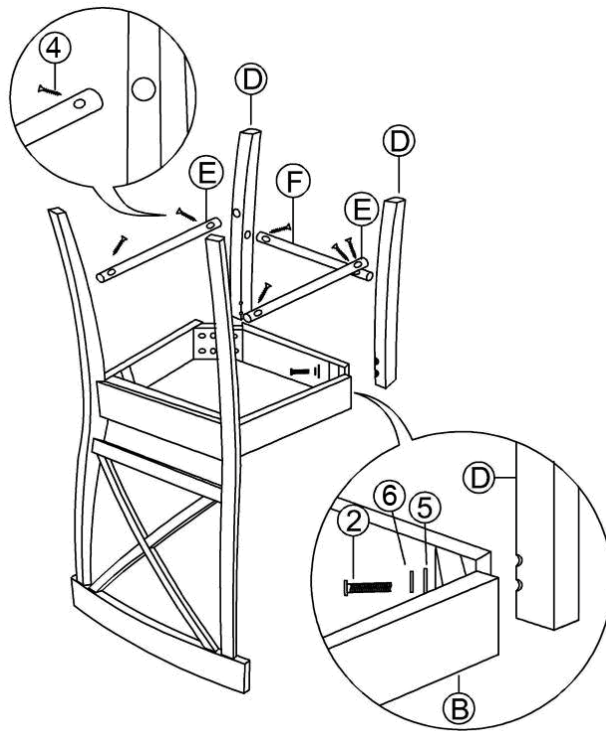

STEP 3

Attach the seat (C) to top of the seat frame (from Step 2) with screws (4). Tighten with the screw driver.

