

# Item # MOTOR25 INSTRUCTION MANUAL

PA

## **READ ALL INSTRUCTIONS AND WARNINGS BEFORE USE**

This manual provides important information on operation & maintenance. These instructions are not meant to cover every possible condition and situation that may occur. We reserve the right to change this product at any time without prior notice. **FOR CONSUMER USE ONLY – NOT FOR PROFESSIONAL USE.**

**IF THERE IS ANY QUESTION ABOUT A CONDITION BEING SAFE OR UNSAFE, DO NOT OPERATE THIS PRODUCT!**

## **HAVE QUESTIONS OR PROBLEMS? CONTACT CUSTOMER SERVICE**

If you experience a problem, have questions or need parts for this product, call Customer Service at **1-866-460-9436, Monday-Friday, 8 AM - 4 PM Central Time**. A copy of the sales receipt is required.

## **KEEP THIS MANUAL, SALES RECEIPT & APPLICABLE WARRANTY FOR FUTURE REFERENCE.**

Keep this manual onboard in a waterproof bag when boating. The manual should stay with the outboard motor if sold.

## **2 YEAR LIMITED EMISSION-RELATED WARRANTY**

THIS ENGINE MEETS U.S. EPA EMISSION STANDARDS UNDER 40 CFR 1054.625. The emission-related limited warranty is valid for two (2) years. Keep the purchase receipt and mail in the product registration card for proof of purchase. Buffalo Corp limits emission-related warranty repairs to authorized service centers for owners located within 100 miles of an authorized service center. For owners located more than 100 miles from an authorized service center, Buffalo Corp will, in its sole discretion, either pay for shipping costs to and from an authorized service center, provide for a service technician to come to the owner to make the warranty repair, or pay for the repair to be made at a local non-authorized service center. The provisions of this paragraph apply only for the contiguous states, excluding the states with high-altitude areas identified in 40 CFR part 1068, Appendix III.

To exercise this warranty, **DO NOT RETURN TO RETAILER**. Instead, call Customer Service toll free at 1-866-460-9436 (email address [info@buffalotools.com](mailto:info@buffalotools.com)) and you will be instructed on where to take the engine for warranty service. Take the engine and proof of purchase (your receipt) to the repair facility recommended by the Customer Service Representative. The warranty does not extend to products damaged or affected by fuel contamination, accidents, neglect, misuse, unauthorized alterations, use in an application for which the product was not designed and any other modifications or abuse.

## **1 YEAR LIMITED WARRANTY (30 Day Limited Warranty for Commercial and Rental Purpose)**

Engines are warranted to be free from defects in materials and workmanship for a period of 1 YEAR from date of original purchase. Buffalo Corp. is not liable for any indirect, incidental or consequential damages from the sale or use of this product. Any implied warranties are limited to 1 YEAR as stated, or as otherwise stated, in this written limited warranty. Some states do not allow the exclusion or limitation of incidental or consequential damages. Some states do not allow limitation on the length of an implied warranty. Buffalo Corp will repair or replace, at its discretion, any part that is proven to be defective in materials or workmanship under normal use during the 1 YEAR warranty period. Warranty repairs or replacements will be made without charge for parts or labor. Parts replaced during warranty repairs will be considered as part of the original product and will have the same warranty period as the original product. This warranty gives you specific legal rights, and you may have other rights that vary state to state.

**ATTENTION: OIL AND GASOLINE IS NOT INCLUDED WITH THE MOTOR AND MUST BE ADDED BEFORE FIRST USE.**

**ATTENTION: FOLLOW ENGINE BREAK-IN PROCEDURE FOR FIRST 20 HOURS OF USE.**

## ITEM # MOTOR25

### 2.6 HP OUTBOARD MOTOR

#### SPECIFICATIONS:

4-Stroke Outboard Motor  
2.6 HP @ 5,500 RPM  
Adjustable Steering Friction  
Full Throttle RPM Range: 5,250-5,750  
Displacement: 72 cc  
Engine type: 1 Cylinder  
Bore & Stroke: 2.13" x 1.24"  
Compression Ratio: 9.0:1  
Fuel/Induction System: SOHV  
Intake: Carburetor  
Exhaust: Above Propeller  
Cooling: Water / Thermostatic Control  
Ignition System: CDI  
Starting System: Manual recoil-start only. (A battery is not available.)  
Lubrication: Splash  
Gear Ratio: (27:12) 2.25:1  
Gear Shift: Forward-Neutral  
Shaft Length: 17"  
Tilt Up Angle: 80°  
Degree of Trim: 4 Positions  
Steering Angle: 360°  
Oil Capacity: 11.84 ounces (SAE10W30)  
Fuel Capacity: 0.32 Gallon (40.5 ounces) Unleaded Gasoline  
Spark Plug: BR6HS  
Spark Plug Gap: 0.6~0.7 mm  
EPA Approved  
Includes: Tool Set  
High Altitude Use: This outboard motor is not recommended for high altitude use above 3,000 ft. If you are using this motor above sea level, it may not function properly because of air flow getting through the carburetor.



If a title is required for your state, contact us for a Certificate of Origin.  
A remote control box (side mount type) is not available.

Transport and store vertically on an engine stand in an upright position. Keep the motor trimmed or tilted down, especially if it's outdoors. This will allow all of the water to drain out of the motor's cooling system. If it's tilted up, some water may remain in the motor, where it can freeze and cause a cracked block or a ruined water pump housing.

## INDEX

Changing Oil	16
Choke	9
Cruising	14
Emissions	46
Engine Break-in	7
Engine Start	9
Engine Warm Up	10
Forward/Reverse	10
Fuel Checklist	8
Fuel Filling	9
Fuel System	15
Fuel Tank	19
Gear Oil	18
Greasing	15
Inspecting	16
Maintenance	14, 20
Oil Level	8
Operation	6
Outboard Motor	7
Parts List	20
Propeller Install	18
Reverse/Forward	11
Shifting	10
Spark Plug	15
Start Engine	9
Stop Engine	12
Tiller	11
Tilting Engine	13
Top Cowling	19
Trimming	12
Warm Up	10

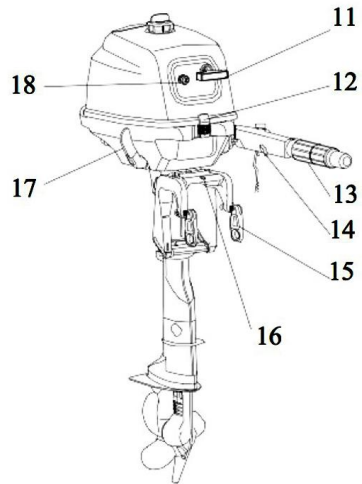
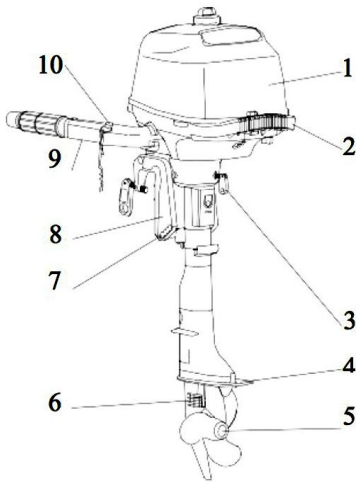

- |                            |   |                      |
|----------------------------|---|----------------------|
| 1. Top cowling             | 8. Clamp bracket                                      | 14. Throttle grip    |
| 2. Carrying handle         | 9. Tiller handle                                      | 15. Clamp screw      |
| 3. Steering friction screw | 10. Engine stop button/<br>Engine stop lanyard switch | 16. Rope attachment  |
| 4. Anti-cavitation plate   | 11. Starter handle                                    | 17. Gear shift lever |
| 5. Propeller               | 12. Top cowling lock levers                           | 18. Choke knob       |
| 6. Cooling water inlet     | 13. Throttle friction adjuster                        |                      |
| 7. Trim rod                |   |                      |

Built-in fuel tank parts are as follows:

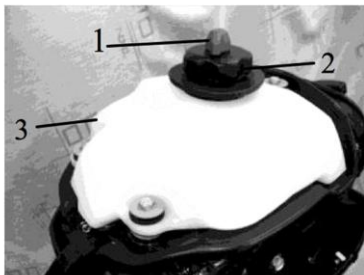

- |                       |                               |
|-----------------------|-------------------------------|
| 1. Air vent screw     | 4. Fuel cock (close position) |
| 2. Fuel tank cap      |                               |
| 3. Built-in fuel tank |                               |

## **⚠ WARNING**

Do not smoke when refueling, and keep away from sparks, flames, or other sources of ignition.

Stop engine before refueling.

Refuel in a well-ventilated area. Refuel portable fuel tanks off the boat.

Do not overfill the fuel tank.

Take care not to spill gasoline, if gasoline spills, wipe it up immediately.

Tighten the filler cap securely after refueling.

If you should swallow some gasoline, inhale a lot of gasoline vapor, or get gasoline in your eye, get immediate medical attentions.

If any gasoline spills onto your skin, immediately wash with soap and water. Change clothing if gasoline spills on it.

Touch the fuel nozzle to metal components to prevent electrostatic sparks.

## **⚠ CAUTION**

Use only new clean gasoline which has been stored in clean containers and is not contaminated with water or foreign matter.

## **⚠ WARNING**

Do not start the engine when the oil level is low. Serious damage might occur.

Always check the oil level before starting the engine.

## **OPERATION**

Mount the outboard motor on the center line (keel line) of the boat.

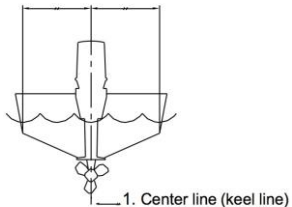

### **NOTE:**

During water testing check the buoyancy of the boat, at rest, with its maximum load. Check that the static water level on the exhaust housing is low enough to prevent water entry into the power head, when water rises due to waves when the outboard is not running.

## **⚠ WARNING**

Overpowering a boat could cause severe instability. Do not install an outboard motor with more horsepower than the maximum rating on the capacity plate of the boat. If the boat does not have a capacity plate, consult the boat manufacturer.

Improper mounting of the outboard motor could result in hazardous conditions. For permanently mounted models, your dealer or other person experienced in proper rigging should mount the motor. If you are mounting the motor yourself, you should be trained by an experienced person. For portable models, your dealer or other person experienced in proper outboard motor mounting should show you how to mount your motor.

The information presented in this section is intended as reference only. Proper mounting depends in part on experience and the specific boat and motor combination.

The mounting height of the outboard motor greatly affects your boat running efficiency. If the mounting height is too high, cavitation tends to occur, thus reducing the propulsion. If the mounting height is too low, the water resistance will increase and thereby reduce engine efficiency. Mount the outboard motor so that the anti-cavitation plate is between the bottom of the boat and a level 25mm below it.

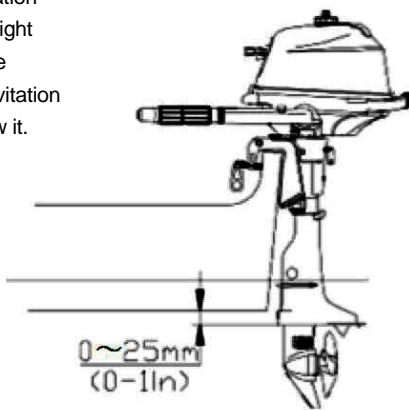

The optimum mounting height of the outboard motor is affected by the boat and motor combination and the desired use. Test runs at a different height can help determine the optimum mounting height.

### Clamping The Outboard Motor

1. Tighten the transom clamp screw evenly and securely. Occasionally check the clamp screws for tightness during operation of the outboard motor because they could become loose due to engine vibration.



### **⚠ WARNING**

Loose clamp screws could allow the outboard motor to fall off or move on the transom. This could cause loss of control.

Make sure the clamp screws are tightened securely. Occasionally check the screws for tightness during operation.

2. If the engine restraint cable attachment is equipped on your engine, an engine restraint cable or chain should be used. Attach to a secure mounting point on the boat to avoid the engine being completely lost if it accidentally falls off the transom.

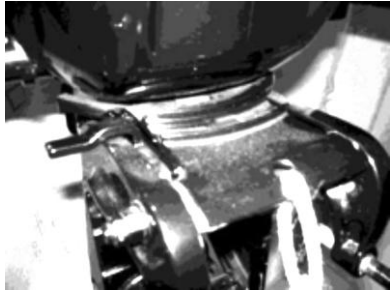

3. Secure the clamp bracket to the transom using the appropriate bolts.

### **Breaking in Engine**

Your new engine requires a period of break-in to allow mating surfaces of moving parts to wear in evenly.

#### **CAUTION**

Failure to follow the break-in procedure could result in reduced engine life or even severe engine damage.

1. For the first hour of operation:

Run the engine at 2000 RPM or at approximately half throttle.

2. For the second hour of operation:

Run the engine at 3000 RPM or at approximately three-quarter throttle.

3. For the next eight hours of operation:

Avoid continuous operation at full throttle for more than five minutes at a time.

4. Operate the engine normally.

### **Pre-Operation Checklist**

#### **Fuel**

Check to be sure you have plenty of fuel for your trip.

Make sure there are no fuel leaks or gasoline fumes.

Check fuel line connections to be sure they are tight.

Be sure the fuel tank is positioned on a secure, flat surface, and that the fuel line is not twisted or flattened, or likely to contact sharp objects.

#### **Controls**

Check throttle, shift and steering for proper operation before starting the engine.

The controls should work smoothly, without binding or unusual free play.

Look for loose or damaged connections.

Check operation of the starter and stop switches when the outboard motor is in the water.

## Engine

Check the engine and engine mounting.

Look for loose or damaged fasteners.

Check the propeller for damage.

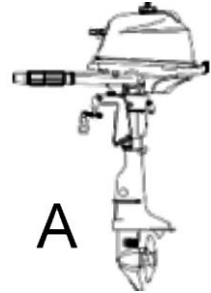

## Checking the Engine Oil Level

1. Put the outboard motor in an upright position (not tilted). (A)

2. Check the oil level using the oil level check window (B) to be sure the level falls between the upper and lower marks. Fill with oil if it is below the lower mark, or drain to the specified level if it is above the upper mark.

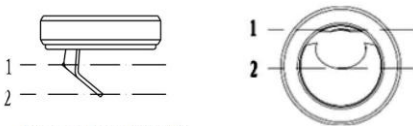

1. Upper level mark

2. Lower level mark

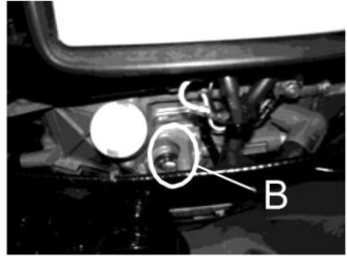

## **⚠ WARNING**

If any item in the pre-operation check is not working properly, have it inspected and repaired before operating the outboard motor. Otherwise an accident could occur.

## **⚠ CAUTION**

Do not start the engine out of water. Overheating and serious engine damage can occur.

## Filling Fuel

Gasoline and its vapors are highly flammable and explosive.

Keep away from sparks, cigarettes, flames, or other sources of ignition.

1. Remove the fuel tank cap.
2. Carefully fill the fuel tank. (C)
3. Close the cap after filling the tank. Wipe up any spilled fuel.

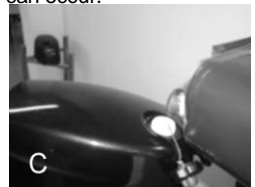



## Starting Engine

1. Loosen the air vent screw on the fuel tank cap.  
One turn for built-in tank. (D)
2. Open the fuel cock. (E)
3. Place the gear shift lever in neutral. (F)



### NOTE:

Attach the engine stop switch lanyard to secure place on your clothing, or your arm or leg. Then install the lock plate on the other end of the lanyard into the engine stop switch. (G)



## **⚠ WARNING**

The engine must be started in neutral, otherwise damage to the starter can occur. Do not attach the lanyard to clothing that could tear loose. Do not route the lanyard where it could become entangled, preventing it from functioning. Avoid accidentally pulling the lanyard during normal operation. Loss of engine power means the loss of steering control. Also, without engine power, the boat could slow rapidly. This could cause people and objects in the boat to be thrown forward.



4. Place the throttle grip in the "START" (start) position. (H)



5. Pull out the choke knob fully. (I)

### NOTE:

It is not necessary to use the choke when starting a warm engine. If the choke is left in the "START" position while the engine is running, the engine will run poorly or stall.

6. Pull the manual starter handle slowly until you feel resistance. Then give a strong pull straight to crank and start the engine. Repeat if necessary. (J)

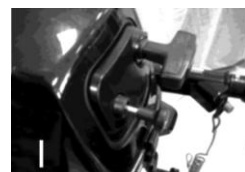

7. After the engine starts, slowly return the manual starter handle to its original position before releasing it.



8. Slowly return the throttle grip to the fully closed position.

## **⚠ CAUTION**

When the engine is cold, it needs to be warmed up. If the engine does not start on the first try, repeat the procedure. If the engine fails to start after 4- 5 tries, open the throttle (between 1/8 and 1/4), and try again.

### **Warming up Engine**

1. After starting the engine, return the choke knob to the halfway position. For approximately the first 5 minutes after starting, warm up the engine by operating at one fifth throttle or less. After the engine has warmed up, push the choke knob in fully.

## **⚠ CAUTION**

If the choke knob is left pulled out after the engine starts, the engine will stall. With temperatures of  $-5^{\circ}\text{C}$  or less, leave the choke knob pulled out fully for approximately 30 seconds after starting.

2. Check for steady flow of water from the cooling water pilot hole. (K)

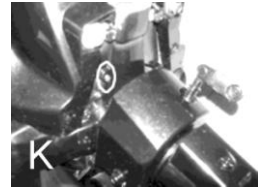

## **⚠ CAUTION**

If water is not flowing out of the hole at all times while the engine is running, stop the engine and check whether the cooling water inlet on the lower case or the cooling water pilot hole is blocked.

### **Shifting**

Before shifting, make sure there are no swimmers or obstacles near you.

## **⚠ CAUTION**

To shift from forward to reverse or vice versa, first close the throttle so that the engine idles (or runs at low speeds).

### **Forward**

1. Place the throttle grip in the fully closed position. (L)
2. Move the gear shift lever quickly and firmly from neutral to forward. (M)

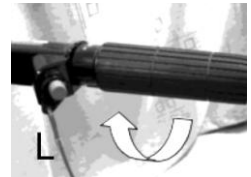

### **Reverse**

When operating in reverse, go slowly. Do not open the throttle more than half. Otherwise the boat could become unstable, which could result in loss of control and an accident.

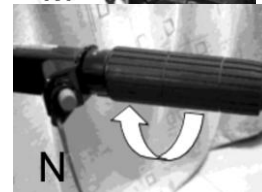

1. Place the throttle trip in the fully closed position. (N)
2. Turning the outboard motor around 180°.
3. Move the gear shift lever quickly and firmly from neutral to reverse. (O)



**NOTE:**

The outboard motor can turn 360° in its bracket (full-pivot system). The boat can also be backed up by simply turning the outboard motor around 180° with the steering handle facing toward you.

**Tiller**

1. Change direction: To change direction, move the tiller handle to the left or right as necessary. (P)

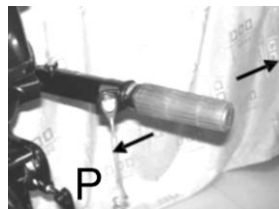

2. Change speed: Turn the grip counterclockwise to increase speed and clockwise to decrease speed.

3. Throttle indicator: The throttle indicator is on the throttle grip. The fuel consumption curve on the throttle indicator shows the relative amount of fuel consumed for each throttle position. (Q)

Choose the setting that offers the best performance and fuel economy for the desired operation.

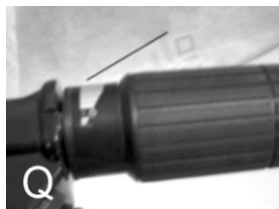

4. The throttle friction adjuster is located on the tiller handle. It provides adjustable resistance to movement of the throttle grip and can be set according to operator preference. To increase resistance, turn the adjuster clockwise. To decrease resistance, turn the adjuster counterclockwise. When constant speed is desired, tighten the adjuster to maintain the desired throttle setting. (R)



**⚠ WARNING**

Do not over-tighten the friction adjuster. If there is too much resistance, it could be difficult to move throttle lever or grip, which could result in an accident.

**Stopping the Engine**

Before stopping the engine, first let it cool off for a few minutes at idle or low speed. Stopping the engine immediately after operating at high speed is not recommended.

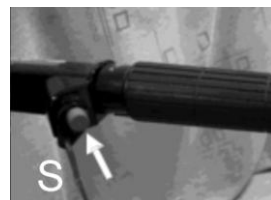

1. Push and hold the engine stop button until the engine comes to a complete stop. (S)

**NOTE:**

If the outboard motor is equipped with an engine stop switch lanyard, the engine can also be stopped by pulling the lanyard and removing the lock plate from the engine stop switch.

2. Tighten the air vent screw on the fuel tank cap (T) and set the fuel cock lever or knob to the closed position. (U)



**Trimming outboard motor**

There are 4 or 5 holes provided in the clamp bracket to adjust the outboard motor trim angle.

1. Stop the engine.

2. Remove the trim rod from the clamp bracket while slightly tilting the outboard motor up. (V)

3. Reposition the rod in the desired hole. Make test runs with the trim set to different angles to find the position that works best for your boat and operating conditions.



**⚠ WARNING**

Stop the engine before adjusting the trim angle.

Use care to avoid being pinched when removing or installing the rod.

Use caution when trying a trim position for the first time. Increase speed gradually and watch for any signs of instability or control problems. Improper trim angle can cause loss of control.

**Tilting Up and Down**

If the engine will be stopped for some time or if the boat is moored in shallows, the outboard motor should be tilted up to protect the propeller and casing from damaged by collision with obstructions, and also to reduce corrosion.

## **⚠ WARNING**

Be sure all people are clear of the outboard motor when tilting up and down, also be careful not to pinch any body parts between the drive unit and engine bracket.

Tighten the air vent screw and place the fuel cock in the closed position if the outboard motor will be tilted for more than a few minutes. Otherwise fuel may leak.

### **NOTE:**

Do not tilt up the engine by pushing the tiller handle because this could break the handle. The outboard motor cannot be tilted when in reverse or when the outboard motor is turn 180 Degrees (facing the rear).



### **Tilting Up**

1. Place the gear shift lever in neutral (if equipped) and face the outboard motor forward. (W)
2. Tighten the steering friction adjuster by turning it clockwise to prevent the motor from turning freely. (X)
3. Tighten the air vent screw (Y), and close the fuel cock.
4. Hold the rear handle and tilt the engine up fully until the tilt support lever automatically locks. (Z)



### **Tilting Down**

1. Slightly tilt the outboard motor up.
2. Slowly tilt the outboard motor down while pulling the tilt support bar lever up.
3. Loose the steering friction adjuster by turning it counterclockwise, and adjust the steering friction according to operator preference.

## **⚠ WARNING**

If there is too much resistance it could be difficult to steer, which could result in an accident.

### **Cruising in Shallow Water**

The outboard motor can be tilted up partially to allow operation in shallow water.

## **⚠ WARNING**

The tilt lock mechanism does not work while the shallow water cruising system is being used. Run the boat at the lowest possible speed to avoid the outboard motor being lifted out of the water, resulting in loss of control.

Return the outboard motor to its normal position as soon as the boat is back in deeper water.

## **⚠ CAUTION**

The cooling water inlet on the lower unit should be not above the surface of the water when setting up for and cruising in shallow water. Otherwise severe damage from overheating can result.

### **Cruising in Salt Water**

After operating in salt water, wash out the cooling water passages with fresh water to prevent them from becoming clogged with salt deposits.

### **Maintenance**

While using the outboard motor, the periodic maintenance is necessary for you to ensure its performance.

## **⚠ WARNING**

Be sure to turn off the engine when you perform maintenance unless otherwise specified. If you or the owner is not familiar with machine servicing, this work should be done by a qualified mechanic.

## **⚠ CAUTION**

If replacement parts are necessary, contact Customer Service for parts of the same type and of equivalent strength and materials.

## Greasing

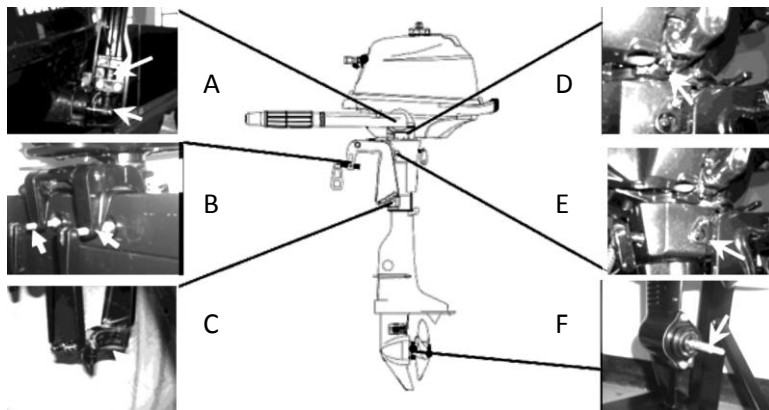

In order to protect the moving spare parts and keep them in good condition, apply grease regularly by using a grease gun at the fitting positions above.

## Cleaning and Adjusting Spark Plug BR6HS

You should periodically remove and inspect the spark plug because heat and deposits will cause the spark plug to slowly break down and erode. If necessary, replace the spark plug with another of the correct type. Before fitting the spark plug, measure the electrode gap with a wire thickness gauge adjust the gap to 0.6 – 0.7mm.



When fitting the plug, always clean the gasket surface and use a new gasket. Wipe off any dirt from the threads and screw in the spark plug to the correct torque.

## Checking the Fuel System

Check the fuel lines for leaks, crack, or malfunction. Repair it immediately, if necessary.



## **⚠ WARNING**

Check for fuel leakage regularly

## Inspecting Idling Speed

A diagnostic tachometer should be used for this procedure. Results may vary depending on whether testing is conducted with the flushing attachment, in a test tank, or with the outboard motor in the water.

1. Start the engine and allow it to warm up fully in neutral until it is running smoothly.

2. Verify whether the idle speed is set to specification. Idle speed:  $1,900 \pm 100$  RPM

### **CAUTION**

Correct idling speed inspection is only possible if the engine is fully warmed up. If not warmed up fully, the idle speed will measure higher than normal.

## **Changing Engine Oil**

Avoid draining the engine oil immediately after stopping the engine. The oil is hot and should be handled with care to avoid burns. The outboard motor is securely fastened to the transom or a stable stand.

### **CAUTION**

Change the engine oil after the first 10 hours of operation, and every 100 hours or at 6-month intervals thereafter. Change the engine oil when the oil is still warm.

1. Put the outboard motor in an upright position (not tilted).
2. Prepare a suitable container that holds a larger amount than the engine oil capacity. Loosen and remove the drain screw while holding the container under the drain hole. Then remove the oil filler cap. Let oil drain completely. Wipe up any spilled oil immediately.
3. Put a new gasket on the oil drain screw. Tighten the drain screw.
4. Add the correct amount of oil through the filler hole. Install the filler cap.
5. Start the engine and make sure that there are no oil leaks.
6. Turn off the engine and wait 3 minutes. Recheck the oil level using oil level check window to be sure the level falls between the upper and lower marks.

### **CAUTION**

The oil should be changed more often when the engine is operated under adverse conditions such as extended trolling.

## **Checking wiring and connectors**

Check that each grounding wire is properly secured and each connector is engaged securely.

## **Checking for leakage**

Check that no exhaust or water leaks from the joints between the exhaust cover, cylinder head, and body cylinder. Check for oil leaks on the around the engine.



## Checking Propeller

Before inspecting, removing or installing the propeller, always take actions to ensure the engine will not accidentally start, such as removing the spark plug caps from the spark plugs, placing the shift control in neutral, and removing the lanyard from the engine stop switch, etc. Serious accident could occur if the engine starts when you are nearby. Do not use your hand to hold the propeller when loosening or tightening the propeller nut. Put a wood block between the anti-cavitation plate and the propeller to prevent the propeller from turning.

1. Check each of the propeller blades for wear, erosion from cavitation or ventilation, or other damage.
2. Check the propeller shaft for damage.
3. Check the splines/shear pin for wear or damage.
4. Check for fish line tangled around the propeller shaft.
5. Check for the propeller shaft oil seal for damage.

## Removing the Propeller

1. Straighten the cotter pin and pull it out using a pair of pliers.
2. Remove the propeller nut, washer, and spacer (if equipped).
3. Remove the propeller and thrust washer.

## Installing the Propeller

Be sure to install the thrust washer before installing the propeller, otherwise the lower case and propeller boss could be damaged.

Be sure to use a new cotter pin and bend the ends over securely. Otherwise the propeller could come off during operation and be lost.

1. Apply a marine grease or corrosion resistant grease to the propeller shaft.
2. Install the spacer (if equipped), thrust washer, and propeller on the propeller shaft.
3. Install the spacer (if equipped) and the washer.
4. Tighten the propeller nut. Align the propeller nut with the propeller shaft hole. Insert a new cotter pin in the hole and bend the cotter pin ends.

## Changing gear oil

### **WARNING**

Be sure the outboard motor is securely fastened to the transom or a stable stand. Never get under the lower unit while the outboard motor is tilted, even when the tilt support lever or knob is locked. Serious injury could occur if the motor falls.

1. Tilt the outboard motor so that the gear oil drain screw is at the lowest point possible.
2. Place a suitable container under the gear case.
3. Remove gear oil drain screw.

### **CAUTION**

Change the gear oil after the first 10 hours of operation, and every 100 hours or at 6-month intervals thereafter. Otherwise the gear will wear quickly.

4. Remove the oil level plug to allow the oil to drain completely.

### **CAUTION**

Inspect the used oil after it has been drained. If the oil is milky, water is getting into the gear case which can cause gear damage. Consult Customer Service.

5. Use a flexible or pressurized filling device, inject the gear oil into the gear oil drain screw hole.
6. When the oil begins to flow out of the oil level plug hole, insert and tighten the oil level plug (If necessary, change the seal spacer).
7. Insert and tighten the gear oil drain screw (If necessary, change the seal spacer).

## Cleaning Fuel Tank

Keep away from sparks, cigarettes, flames, or other sources of ignition when cleaning the fuel tank. Cleaning the fuel tank in a well-ventilated open air.

1. Empty the fuel tank into an approved container.
2. Pour a small amount of suitable solvent into the tank. Install the cap and shake the tank. Drain the solvent completely.
3. Pull the fuel joint assembly out of the tank.
4. Clean the filter in a suitable cleaning solvent and allow it to dry.
5. Replace the gasket with a new one. Reinstall the fuel joint assembly and tighten the screws firmly.

## Checking and Replacing Anode(s)

Inspect the external anodes periodically. Remove scales from the surfaces of the anodes.

### CAUTION

Do not paint anodes, as this would render them ineffective and can cause more rapid engine corrosion.

## Checking Top Cowling

Check the fitting of the top cowling by pushing it with both hands. If it is loose have it repaired.

## Maintenance Table

When utilized under normal condition, maintained and repaired in the proper manner, the motor can work normally within the normal life period. Frequency of maintenance operations may be adjusted according to the operating conditions, but the following table gives general guidelines.

The “●” symbol indicates the check-ups which you may carry out by yourself. The “○” symbol indicates work to be carried out by you.

Item	Operations	Initial		Every	
		10 hours ( 1 month )	50 hours ( 3 months )	100 hours ( 6 months )	200 hours ( 1 year )
Anode(s) (external)	Check/replacement		●/○	●/○	
Anode(s) (internal)	Check/replacement				○
Cooling water passages	Cleaning		●	●	✱
Cowling clamp	Check				●
Fuel filter (disposable)	Check/cleaning	●	●	●	
Fuel system	Check	●	●	●	
Fuel tank (portable tank)	Check/cleaning				●
Gear oil	Change	●		●	
Greasing points	Greasing			●	
Idling speed (carburetor models)	Check/adjustment	●/○		●/○	
Propeller and cotter pin	Check/replacement		●	●	
Shift link/shift cable	Check/adjustment				○
Thermostat	Check				○
Throttle link/throttle cable/Throttle pick-up timing	Check/adjustment				○
Water pump	Check				○
Engine oil	Check/replacement	●		●	
Oil filter	Change				○
Spark plug (s)	Cleaning/adjustment/replacement	●			●
Timing belt	Check/replacement			○	○
Valve clearance (OHC, OHV)	Check/adjustment	○		○	

## PARTS LIST / PARTS DIAGRAM

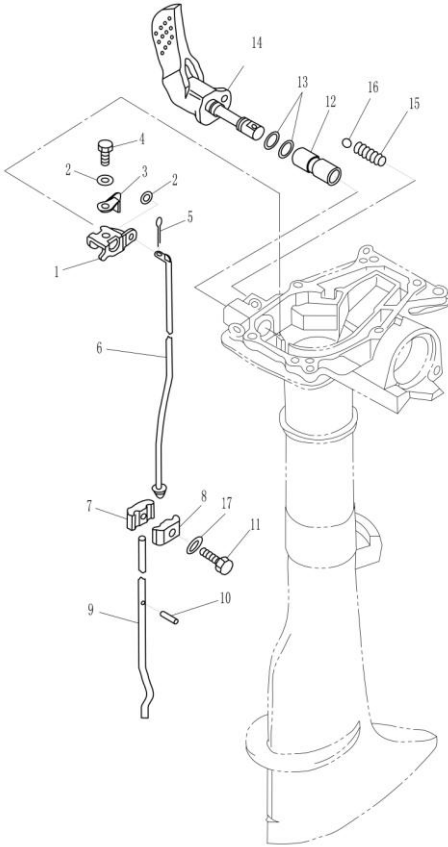

## CONTROL

SN.	PART NO.	DESCRIPTION	QTY
1	F2.6-02000006	LEVEL, SHIFT ROD	1
2	GB/T97.1-5	WASHER 5	3
3	F2.6-02000008	WASHER, SHIFT ROD LEVER	1
4	GB/T5783-M5x12	BOLT M5x12	1
5	GB/T91-1.6x12	PIN, COTTER 1.6x12	1
6	F2.6-02000007	ROD SHIFT	1
7	F2.6-00000001	CONNECTOR, SHIFT ROD A	1
8	F2.6-00000002	CONNECTOR, SHIFT ROD B	1
9	F2.6-03000005S	SHIFT CAMSHAFT(S)	1
	F2.6-03000005L	SHIFT CAMSHAFT(L)	1
10	GB/T879.2-2.5x14	PIN 2.5x14	1
11	GB/T5783-M6x20	BOLT M6x20	1
12	F4-02000002A	BUSHING, SHIFT ROD LEVER	2
13	JISB2401-P9	O-RING	2
14	F2.6-02020000	GAE SHIFT HANDLE ASSY	1
15	F4-02000003	SPRING, GEAR	1
16	GB/T308-8	BALL 8	1
17	F4-00000005	WASHER	1

BRACKET

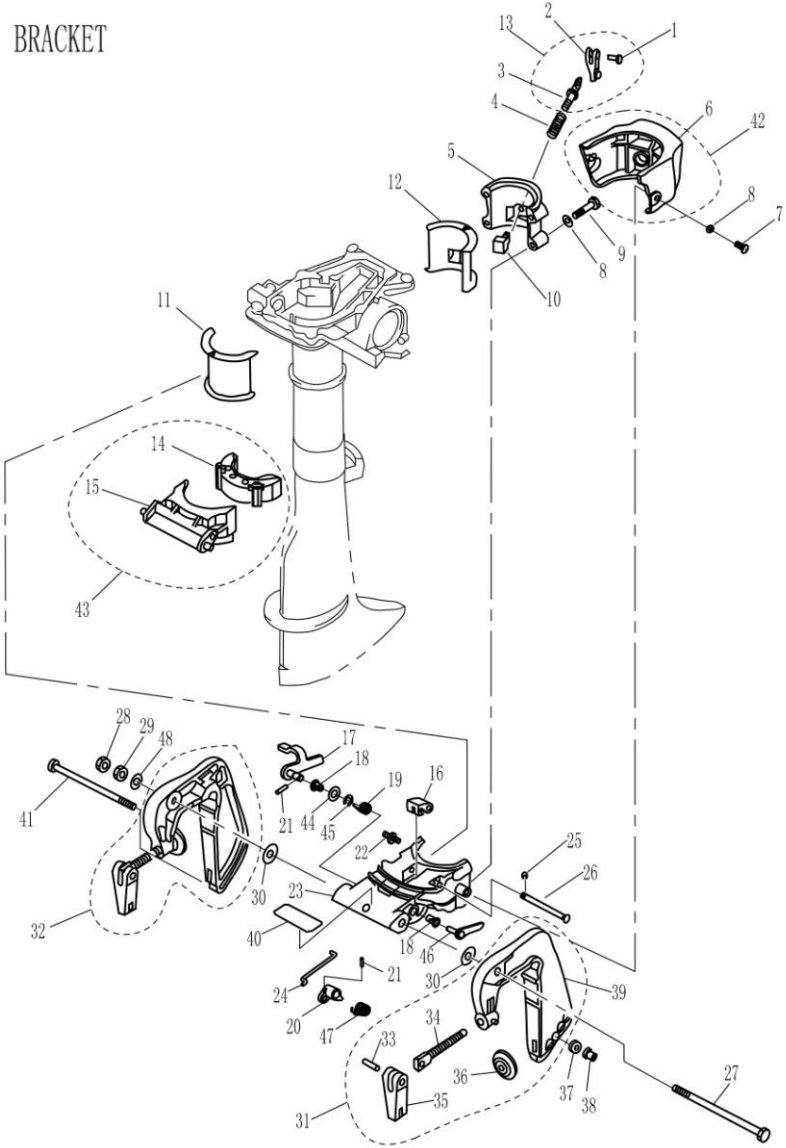

# BRACKET

SN.	PART NO.	DESCRIPTION	QTY
1	GB/T875-4x11	RIVET $\Phi$ 4x11	1
2	F4-01060002	CLAMP HANDLE	1
3	F2.6-01050101	LOCKED SCREW	1
4	F2.6-01050002	SPRING	1
5	F2.6-01050001	COVER, SWIVEL BRACKET	1
6	F2.6-00000101	COVER, BRACKET	1
7	GB/T818-M6x16	SCREW, PAN HEAD M6x16	2
8	GB/T97.1-6	WASHER 6	6
9	GB/T5783-M6x30	BOLT M6x30	4
10	F2.6-01050200	LOCKED BLOCK ASSY	1
11	F2.6-01000003	BUSHING A	1
12	F2.6-01000004	BUSHING B	1
13	F2.6-01050100	LOCKED HANDLE ASSY	1
14	F2.6-01040100	DAMPER	1
15	F2.6-01040001	BRACKET , THRUST RECEIVE	1
16	F2.6-01030007	LEVER	1
17	F2.6-01030100-A	TILT CLAMP HANDLE ASSY	1
18	F4-01090006	BUSHING	2
19	F2.6-01030003-A	SPRING	1
20	F2.6-01030004-A	LEVER, TILT LOCK	1
21	GB/T879.2-2x10	PIN $\Phi$ 2x10	2
22	GB/T7940.1-M6	NIPPLE, GREASE M6	1
23	F2.6-01030001	BRACKET, SWIVEL	1
24	F2.6-01030005-A	ROD, TILT LOCK	1

SN.	PART NO.	DESCRIPTION	QTY
25	GB/T896-3.5	CLIP 3.5	1
26	F2.6-01030006	PIN	1
27	F2.6-01000001	BOLT	1
28	GB/T6172.1-M8	NUT M8	1
29	GB/T6170-M8	NUT M8	1
30	GB/T96-8	WASHER 8	2
31	F2.6-01010000	BRACKET LEFT ASSY	1
32	F2.6-01020000	BRACKET RIGHT ASSY	1
33	F4-01010005	RIVET	2
34	F4-01010002	CLAMP BOLT	2
35	F4-01010004	CLAMP SHIPBOARD HANDLE	2
36	F4-01010003	CLAMP PLATE	2
37	F2.6-01000002	BUSH , BOLT	1
38	GB/T889.1-M6	NUT M6	1
39	F2.6-01010001	BRACKET, CLAMP (LEFT)	1
40	F2.6-07000009	MARK 9	1
41	GB/T5782-M6x125	BOLT M6x125	1
42	F2.6-00000100	BRACKET COVER ASSY	1
43	F2.6-01040000	THRUST RECEIVE ASSY	1
44	F2.6-01030009	WASHER, CLAMP HANDLE	1
45	GB/T896-6	CIRCLIP 6	1
46	F2.6-01030200	TILT BAR	1
47	F2.6-01030008	SPRING, TILT BAR	1
48	GB/T97.1-8	WASHER 8	1

# STEERING

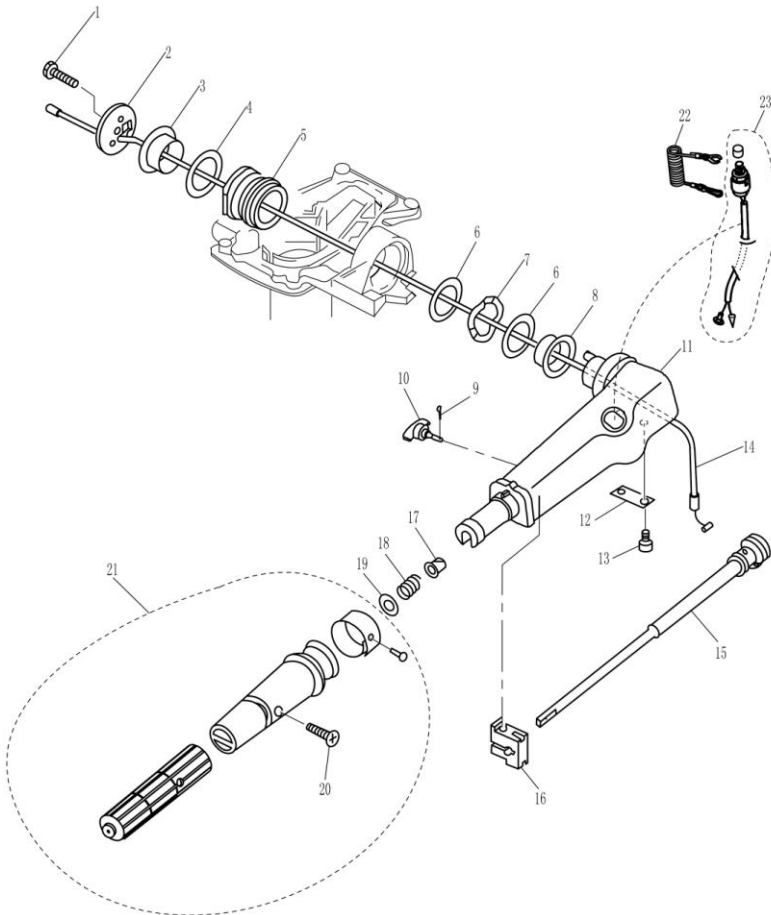

№	PART NO.	DESCRIPTION	QTY
1	GB/T5783-M8x25	BOLT M8x25	1
2	F4-01000014	COVER, HANDLE STEERING	1
3	F4-01000008	BUSH B, HANDLE	1
4	F4-01000011	WASHER A, BUSH	1
5	F4-05000014	HANDLE DAMPER ASSY	1
6	F4-01000010	WASHER R, BUSH	2
7	F4-01000012	BUSH, WAVE	1
8	F4-01000009	BUSH A, HANDLE	1
9	GB/T91-1.6x12	PIN, CUTTER 1.6x12	1
10	F4-01090200	BOLT, FRICTION ADJUSTING	1
11	F4-01090001	HANDLE, STEERING	1
12	F4-01090002	STAY	1

№	PART NO.	DESCRIPTION	QTY
13	GB/T818-45x12	SCREW, PAN HEAD M5x12	2
14	F4-01090008	THROTTLE CABLE ASSY	1
15	F4-01090100	LEVER, THROTTLE ASSY	1
16	F4-01090003	FRICTION	1
17	F4-01090006	BUSH	1
18	F4-01090007	SPRING	1
19	GB/T848-10	WASHER 10	1
20	GB/T820-M5x24	SCREW M5x24	1
21	F2.6-02010100	STEERING HANDLE ASSY	1
22	F4-01090401	STOPER, HANG ROPE ASSY	1
23	F2.6-02010200	ENGINE STOP SWITCH ASSY	1

UPPER CASING

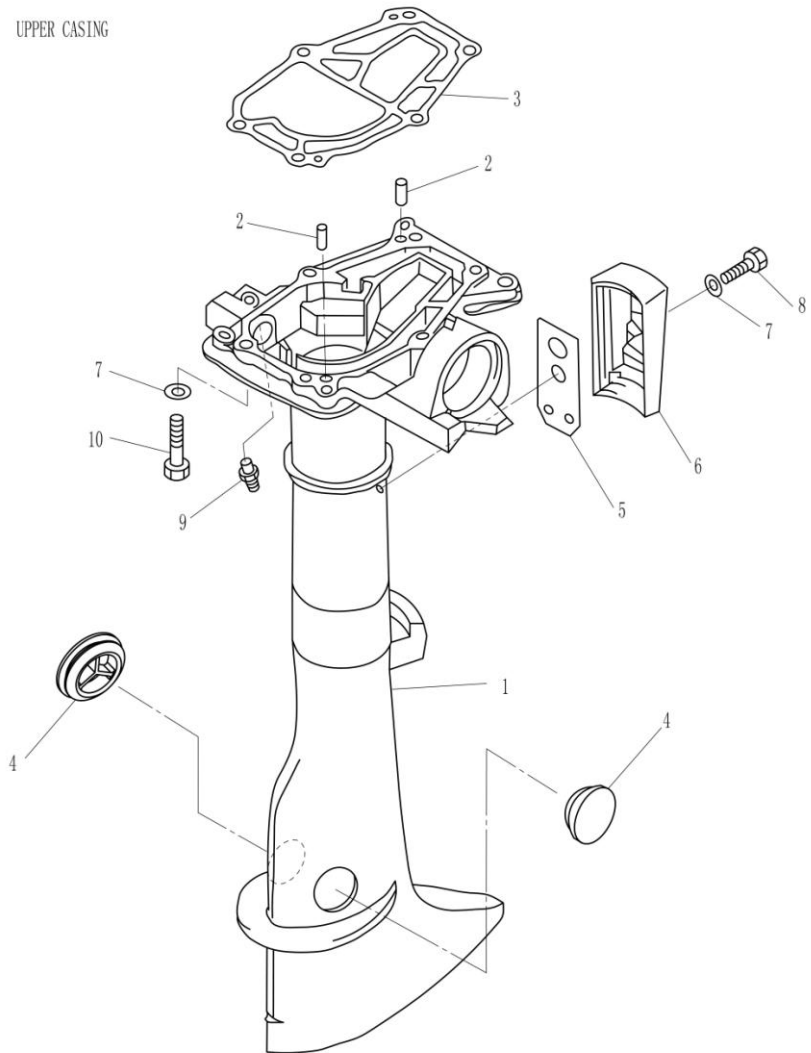

SN.	PART NO.	DESCRIPTION	QTY
1	F2.6-02000001	UPPER CASING	1
2	F15-0000013	PIN	2
3	F2.6-0000003A	GASKET, ENGINE	1
4	F4-02000012	RUBBER PLUG, UPPER	2
5	F2.6-02000005	GASKET, EXHAUST COVER	1

SN.	PART NO.	DESCRIPTION	QTY
6	F2.6-02000004	EXHAUST COVER	1
7	GB/T97.1-6	WASHER 6	7
8	GB/T818-M6x16	SCREW M6x16	1
9	GB/T7940.1-M6	GREASE CUP M6	1
10	GB/T5783-M6x35	BOLT M6x35	6



LOWER CASING & DRIVE 1

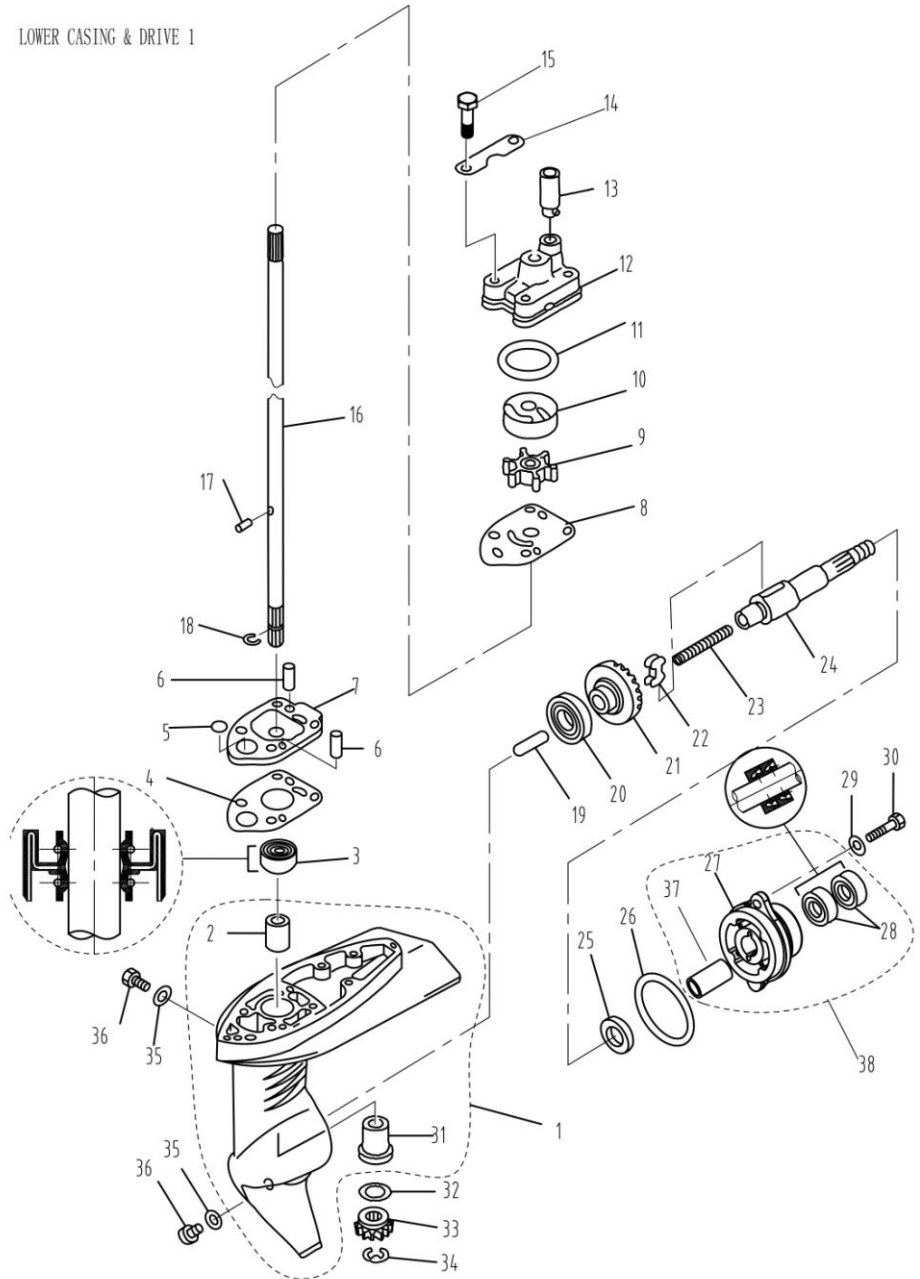

LOWER CASING & DRIVE 1

S/N	PART NO.	DESCRIPTION	QTY
1	F2.6-03000001	LOWER CASING	1
2	F2.6-03000003	BEARING	1
3	F2.6-03000004	OIL SEAL9.8x24x9	1
4	F2.6-03000007	GASKET, WATER PUMP	1
5	F2.6-03000009	O-RING 4.9X3.5	1
6	F4-03000013	PINφ4x18	2
7	F2.6-03000008	HOUSING, WATER PUMP	1
8	F2.6-03000010	OUT PLATE	1
9	F2.6-03000100	IMPELLER ASSY	1
10	F2.6-03000015	COVER, INNER WATER PUMP	1
11	JASO F404-19-033	O-RING 33X2	1
12	F2.6-03000014	WATER PUMP HOUSING	1
13	F4-03000021	RUBBER TUBE, WATER PUMP	1
14	F2.6-03000016	PLATE, WATER PUMP FIXED	2
15	GB/T5783-M6x40	BOLT M6x40	4
16	F2.6-03000011	DRIVE SHAFT	1
17	F2.6-03000013	PINφ3.5×7	1
18	F2.6-03000012	CLIP	1
19	F2.6-03000020	PLUG, SHIFT	1

S/N	PART NO.	DESCRIPTION	QTY
20	GB/T276-16003/P63	BALL BEARING	1
21	F2.6-03000019	POSITIVE GEAR ASSY	1
22	F2.6-03000202	CLUTCH BLOCK	1
23	F4-03030003	SPRING, CLUTCH BLOCK	1
24	F2.6-030000201	SHAFT, PROPELLER	1
25	F2.6-03000021	WASHER	1
26	JISB 2401-P48	O-RINGφ47.7x3.5	1
27	F2.6-03000301	COVER, LOWER CASING	1
28	F4-03050002	OIL SEAL13x22x7	2
29	GB/T5783-M6x16	BOLT M6x16	2
30	GB/T97.1-6	WASHER 6	2
31	F2.6-03000002	BEARING	1
32	F2.6-03000017	SHIM(T:2.0MM)	1
33	F2.6-03000018	INITIATIRE GEAR	1
34	GB/T896-6	CIRCLIP 6	1
35	F4-03000024	GASKET	2
36	F4-03000023	PLUG, OIL HOLE	2
37	F2.6-03000302	BEARING , SLEEVE	1
38	F2.6-03000300	COVER ASSY , LOWER CASING	1

LOWER CASING & DRIVE 2

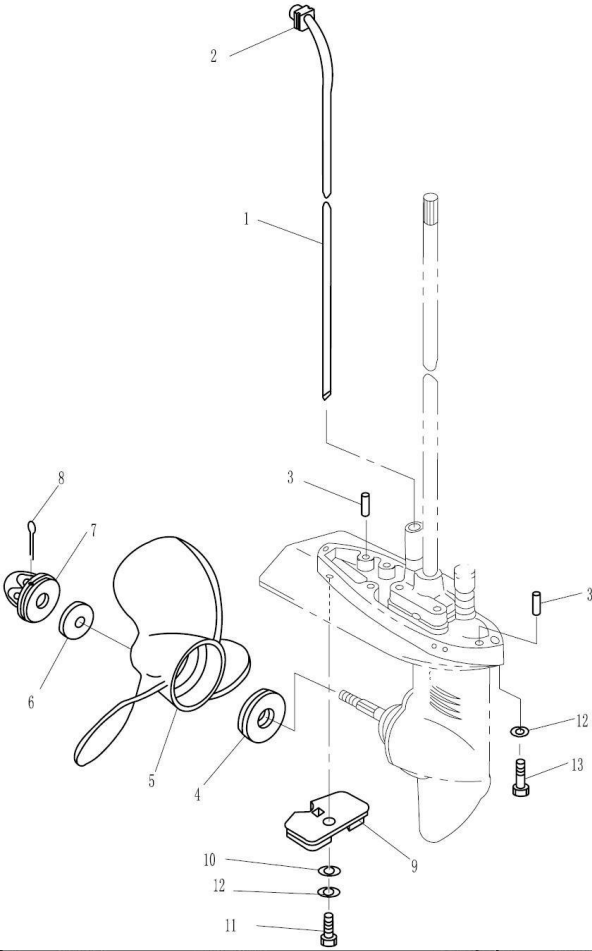

SN.	PART NO.	DESCRIPTION	QTY	SN.	PART NO.	DESCRIPTION	QTY
1	F2.6-02000003	WATER TUBE	1	7	F4-03080000	NUT ASSY	1
2	F4-02040002	T-SHAPED RUBBER BAND	1	8	GB/T91-2.5x30	PIN, COTTER 2.5x30	1
3	F15-00000013	PIN	2	9	F4-03000022	ANODE	1
4	F4-03000025	SPACER	1	10	GB/T861.1-6	WASHER, INTERNAL TOUCH 6	1
5	F2.6-03010000	PROPELLER ASSY	1	11	GB/T5783-M6x12	BOLT M6x12	1
6	F4-03000026	WASHER	1	12	GB/T97.1-6	WASHER 6	4
				13	GB/T5783-M6x30	BOLT M6x30	3

# IGNITION ASSY

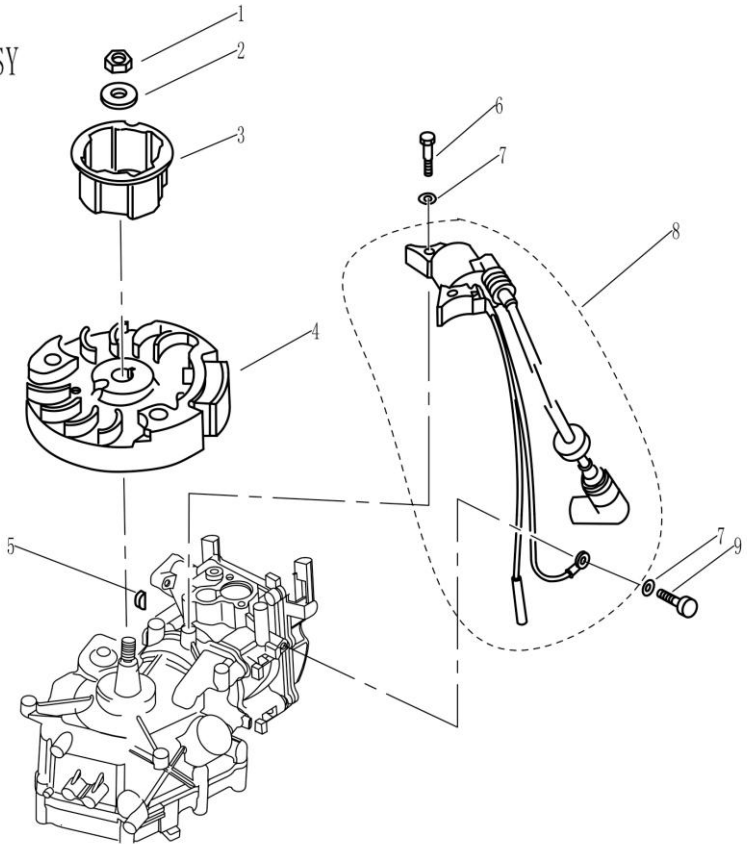

SN.	PART NO.	DESCRIPTION	QTY
1	F4-0400026	NUT M10x1.25	1
2	F4-0400021	WASHER	1
3	F2.6-0400016	PULLEY, STARTER	1
4	F2.6-0400040	FLYWHELL ASSY	1
5	F4-0400019	KEY	1
6	GB/T5783-M6x25	BOLT M6x25	2
7	GB/T97.1-6	WASHER 6	3
8	F2.6-04000600	HIGH PRESSURE ASSY	1
9	GB/T5783-M6x12	BOLT M6x12	1

CYLINDER & CRANKCASE 1

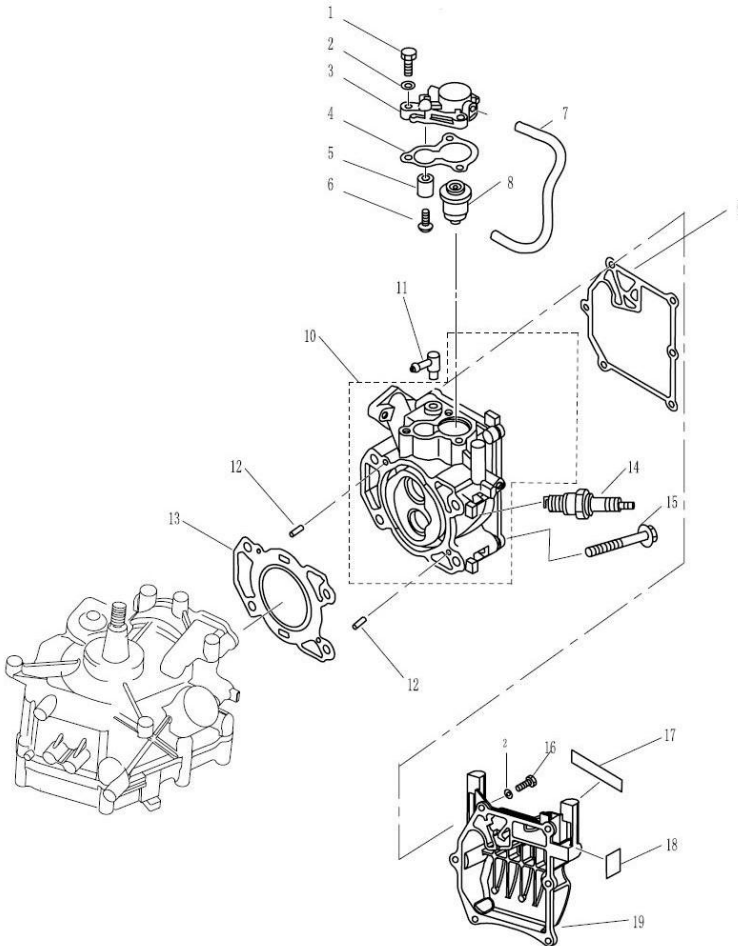

SN.	PART NO.	DESCRIPTION	QTY	SN.	PART NO.	DESCRIPTION	QTY
1	GB/T5783-M6x20	BOLT M6x20	3	10	F2.6-04040100	CYLINDER HEAD ASSY	1
2	GB/T97.1-6	WASHER, PLATE 6	9	11	F15-04000005	SPILE WATER ASSY	1
3	F2.6-04000501	COVER, THERMOSTAT	1	12	F15-00000013	PIN	2
4	F4-04000011	GASKET, THERMOSTAT	1	13	F2.6-04000001	GASKET, CYLINDER HEAD	1
5	F4-04070003	ANODE	1	14	NGK BPR7HS	SPARK PLUG	1
6	GB/T818-M5x25	SCREW, PAN HEAD M5x25	1	15	F4-04000034	BOLT	4
7	F2.6-04000007	PIPE, WATER	1	16	GB/T5783-M6x16	BOLT M6x16	6
8	T15-04000010	THERMOSTAT	1	17	F2.6-07000008	MARK 8	1
9	F2.6-04000005	GASKET, CYLINDER COVER	1	18	F4-08000110	MARK 10	1
				19	F2.6-04000006	COVER, CYLINDER HEAD	1

# CRANKSHAFT & PISTON

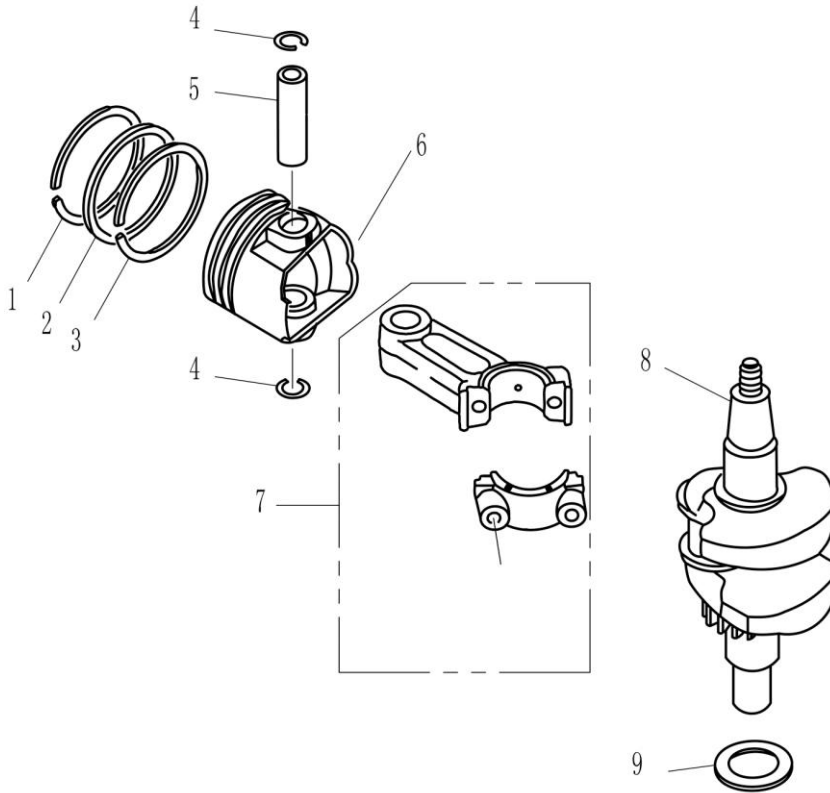

SN.	PART NO.	DESCRIPTION	QTY
1	F2. 6-04020002	PISTON RING 1	1
2	F2. 6-04020003	PISTON RING 2	1
3	F2. 6-04020004	COMBINED OIL RING	1
4	F2. 6-04020006	CIRCLIP	2
5	F2. 6-04020005	PIN, PISTON	1
6	F2. 6-04020001	PISTON	1
7	F2. 6-04020100	ROD, CONNECTING	1
8	F2. 6-04030000	CRANK ASSY	1
9	F2. 6-04000003	WASHER, PLATE	1

# CAMSHAFT & VALVE

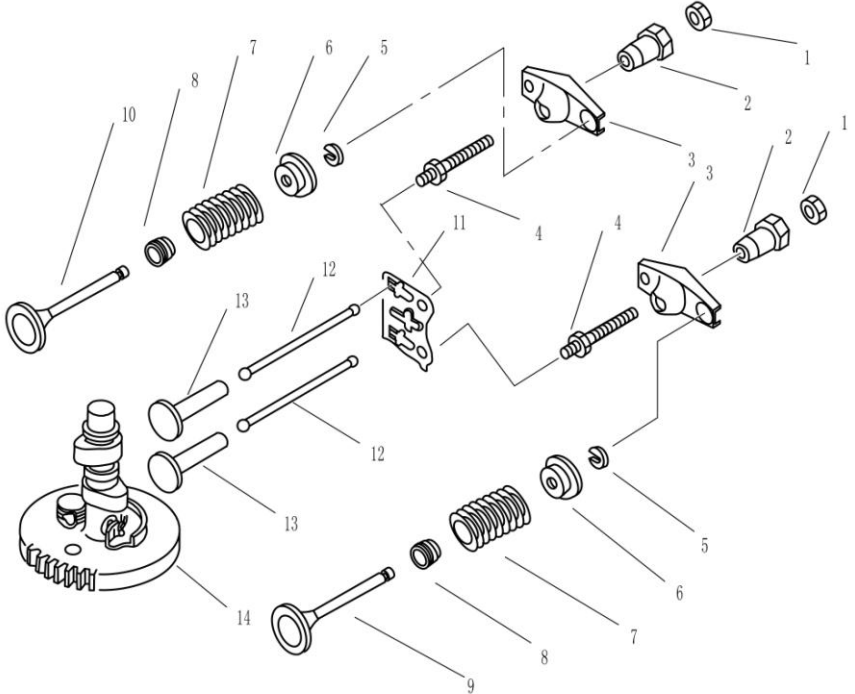

SN.	PART NO.	DESCRIPTION	QTY
1	166F-010011	LOCK NUT	2
2	166F-010010	PIVOT, ROCKER ARM	2
3	166F-010009	ARM, VALVE ROCKER	2
4	116F-010008	BOLT, ROCKER ARM	2
5	F8-05030007	CLAMP, VALVE	2
6	F8-05030006	RETAINER, VALVE SPRING	2
7	F4-04080008	SPRING, VALVE STEM	2
8	166F-010003	SEAL, VALVE STEM	2
9	F4-04080005A	VALVE, INTAKE	1
10	F4-04080006A	VALVE, EXHAUST	1
11	F2.6-04040001	PLATE, PUSH ROD	1
12	F2.6-04000002	ROD, VALVE PUSH	2
13	166F-000001	LIFTER, VALVE	2
14	F2.6-04000100	CAMSHAFT ASSY	1

# CYLINDER & CRANKCASE 2

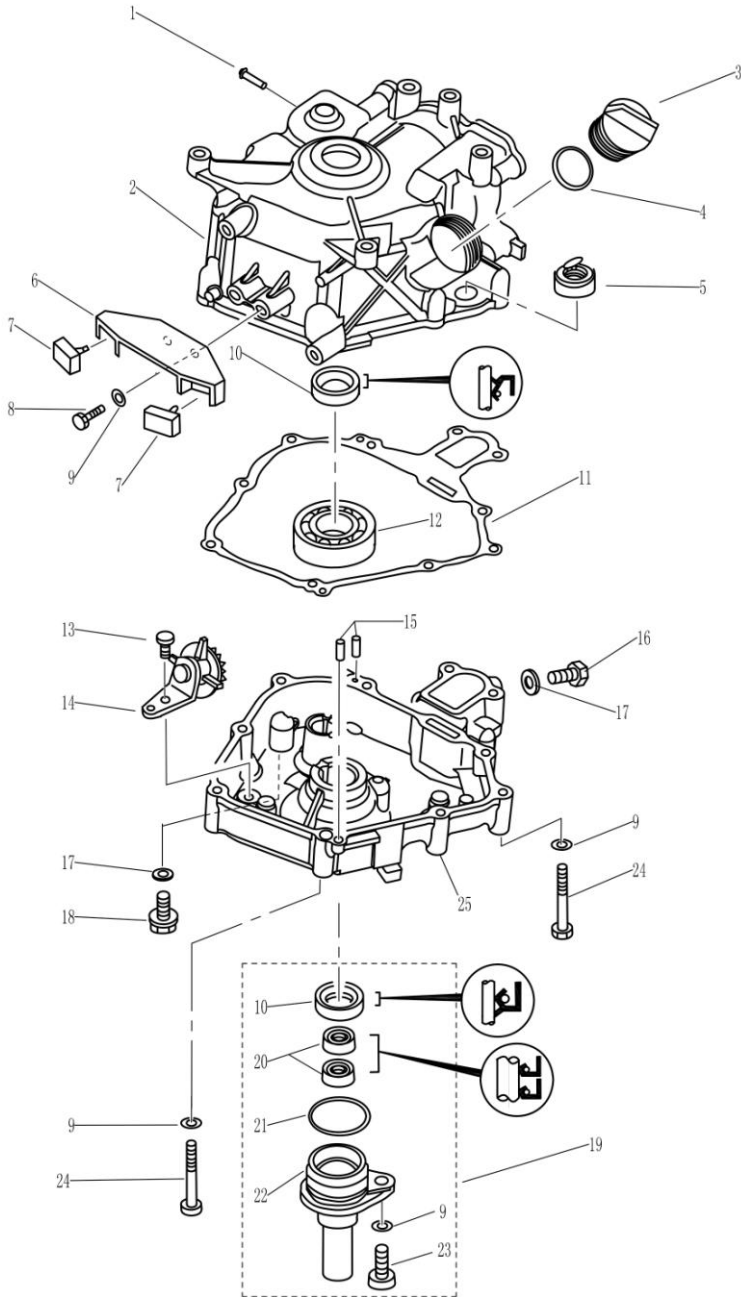



## CYLINDER & CRANKCASE 2

SN.	PART NO.	DESCRIPTION	QTY
1	T15-04010202	PIPE, WATER	1
2	F2.6-04010100	CRANK CASE	1
3	F15-07050004	PLUG, OIL	1
4	JASO F404-31-025	O-RING	1
5	F2.6-04010102	GAUGE, LEVEL	1
6	F2.6-04000008	BRACKET , DAMPER	1
7	F2.6-04000009	RUBBER BLOCK , DAMPER	2
8	GB/T5783-M6x20	BOLT M6x20	2
9	GB/T97.1-6	WASHER 6	11
10	F2.6-04010001	OIL SEAL SD 20X30X7 HS	2
11	F2.6-04000004	CRANK CASE COMPLEX GASKET	1
12	GB/T276-62/22/P6	BALL BEARING	1
13	GB/T5783-M6x12	BOLT M6x12	1
14	F2.6-04050100	GEAR UNT ASSY	1
15	F15-00000013	PIN Ø4X12	2
16	GB/T5783-M8x14	BOLT M8x14	1
17	F4-04000006	WASHER	2
18	F4-04000001	BOLT , DISCHARGING OIL	1
19	F2.6-04060000	OIL SEAL SHELL ASSY	1
20	F2.6-04060002	OIL SEAL K-5657	2
21	F4-04060002	O RING	1
22	F2.6-04060001	SHELL , OIL SEAL	1
23	GB/T5783-M8x20	BOLT M8x20	1
24	GB/T5782-M6x45	BOLT M6x45	8
25	F2.6-04050001	COVER, CRANK CASE	1

# FUEL

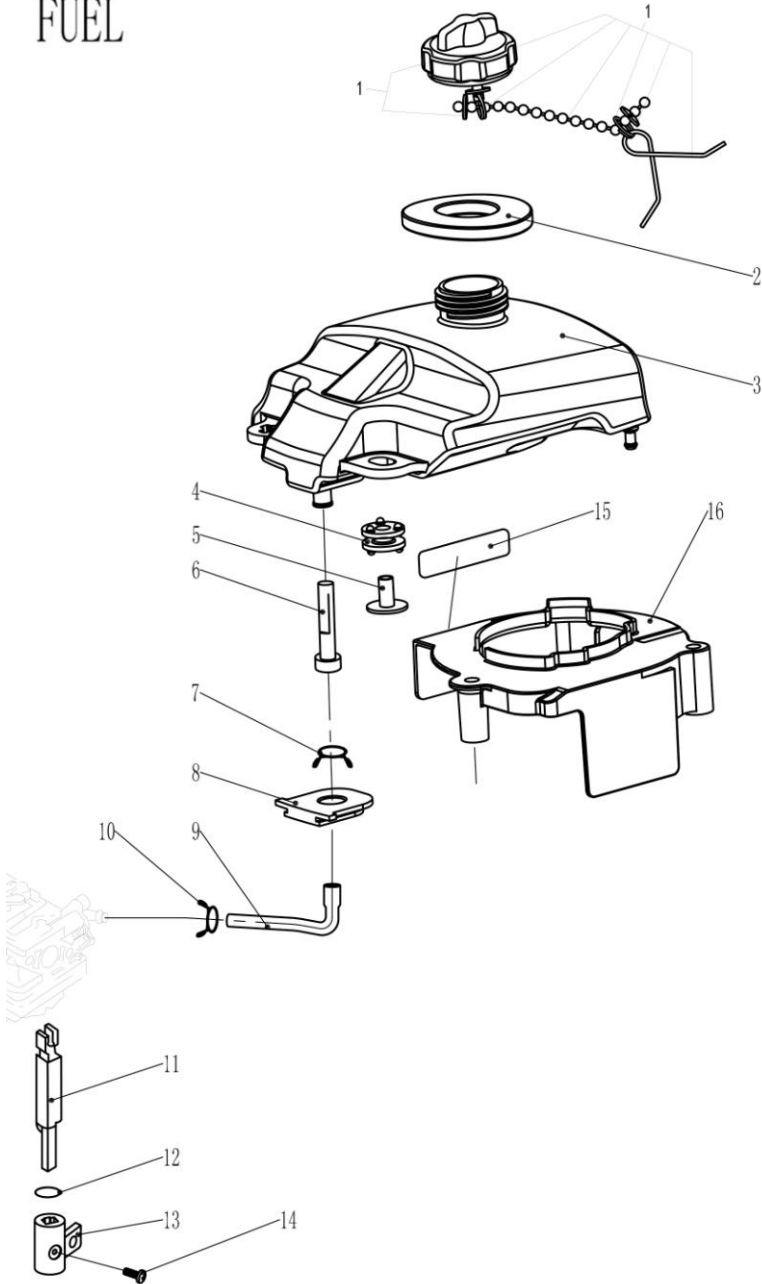

# FUEL

SN.	PART NO.	DESCRIPTION	QTY
1	F4-04120100	TANK COVER ASSY	1
2	F2.6-04000033	WASHER , DAMPER	1
3	F2.6-04000026	FUEL TANK , INNER	1
4	F2.6-04000027	DAMPER , FUEL TANK	2
5	F2.6-04000028	TUBE , DAMPER	2
6	F4-04120005	FILTER , FUEL TANK	1
7	F4-05000010	SPRING , OIL TUBE	1
8	F4-04000032	DAMPER , OIL TUBE	1
9	F2.6-04000029	OIL TUBE	1
10	F2.6-04000030	SPRING , OIL TUBE	1
11	F2.6-04000017	CONNECTING-ROD, OIL SWITCH	1
12	JASOF404-24-014	O-RING $\Phi 13.8 \times 2.4$	1
13	F2.6-00000004	KNOB , OIL SWITCH	1
14	GB/T823-M5x8	SCREW , PAN HEAD M5x8	1
15	F2.6-07000007	MARK 7	1
16	F2.6-04000022	VENTILATIVE COVER	1

# INTAKE

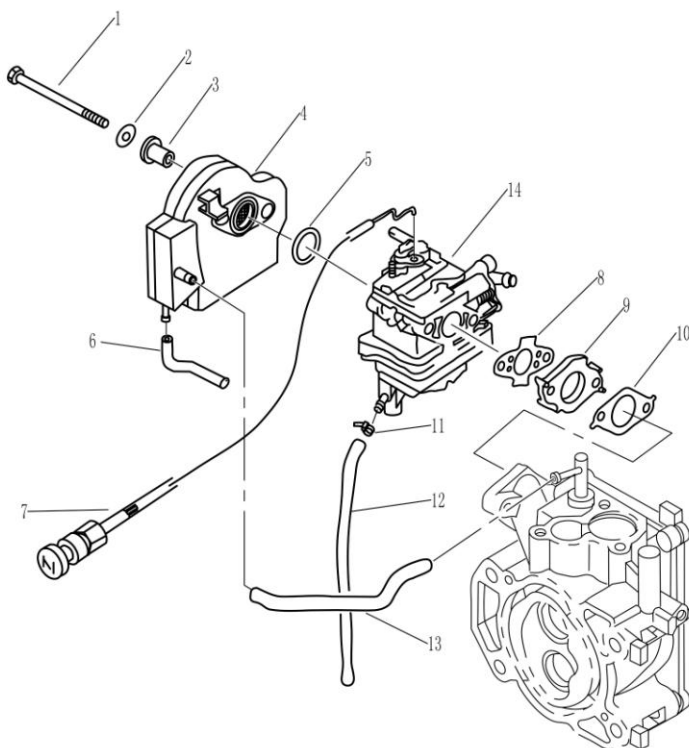

SN.	PART NO.	DESCRIPTION	QTY
1	GB/T5782-M6x75	BOLT M6x75	2
2	GB/T97.1-6	WASHER 6	2
3	F2.6-0400012	BUSH, INTAKE SILENCE	2
4	F2.6-04000300	SILENCE ASSY, INTAKE	1
5	JASO F404-24-021	O-RING	1
6	F2.6-0400015	HOSE $\Phi 2.5 \times \Phi 7 \times 72$	1
7	F2.6-04070200	CHOCK HANDLE ASSY	1
8	F2.6-0400018	GASKET, CARBURETOR AIRPROOF	1
9	F2.6-0400011	INSULATOR, CARBURETOR	1
10	F2.6-0400010	GASKET, CARBURETOR AIRPROOF	1
11	HT2.5x60	CLAMP 60x2.5	1
12	F2.6-0400013	HOSE $\Phi 4 \times \Phi 7 \times 140$	1
13	F2.6-0400014	HOSE $\Phi 5 \times \Phi 9 \times 130$	1
14	F2.6-04000200	CARBURETOR	1

STARTER ASSY

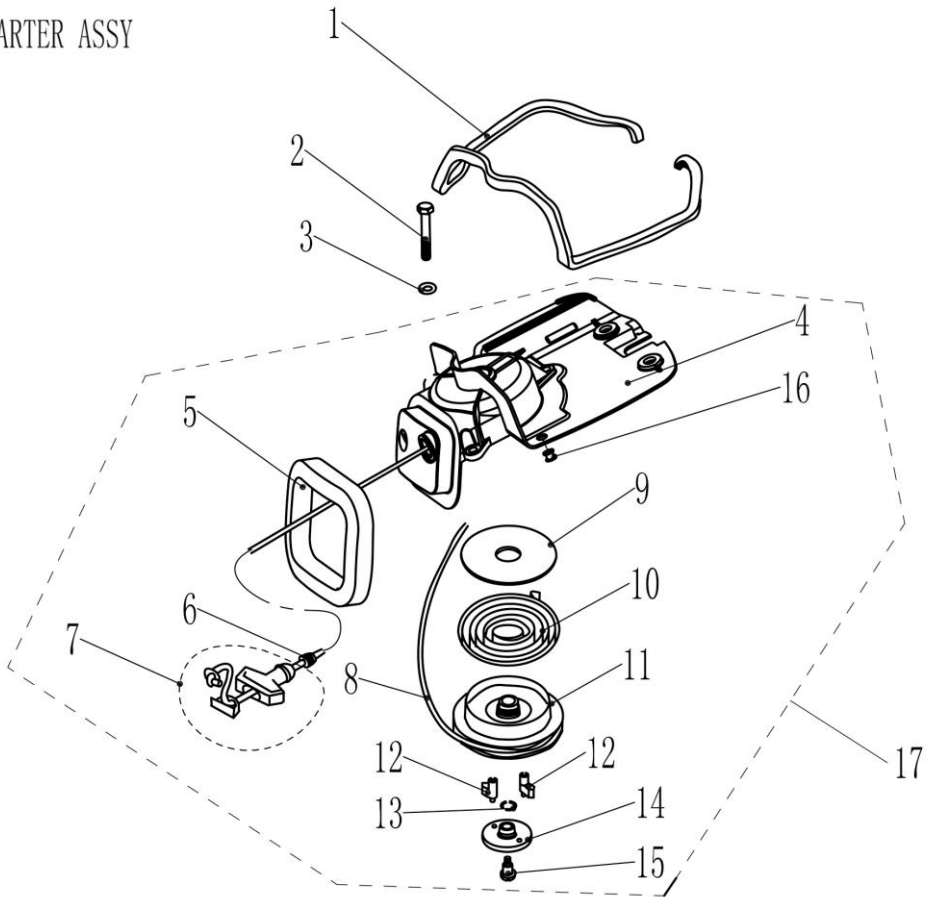

# STARTER ASSY

SN.	PART NO.	DESCRIPTION	QTY
1	F2.6-04070002	SEAL, RUBBER	1
2	GB/T5782-M6x60	BOLT M6x60	3
3	GB/T97.1-6	WASHER 6	3
4	F2.6-04070100	CASE, STARTER	1
5	F2.6-04070001	SEAL, RUBBER	1
6	F2.6-04070008	DAMPER, HANDLE	1
7	F4-04130100	STARTER HANDLE ASSY	1
8	F2.6-04070007	WIRE, STARTER Φ3	1
9	F2.6-04070003	WASHER, THRUST	1
10	F4-04130005	SPRING, VOLUTE	1
11	F2.6-04070004	<b>Recoil Housing</b>	1
12	F2.6-04070005	SPRING	2
13	F4-04130007	BOLT, STARTER	1
14	F2.6-04070006	PLATE, PRESS	1
15	F4-04130008	SCREW, STARTER	1
16	F2.6-04000034	DAMPER , FUEL TANK	2
17	F2.6-04070000	STARTER ASSY	1

# BOTTOM COWLING

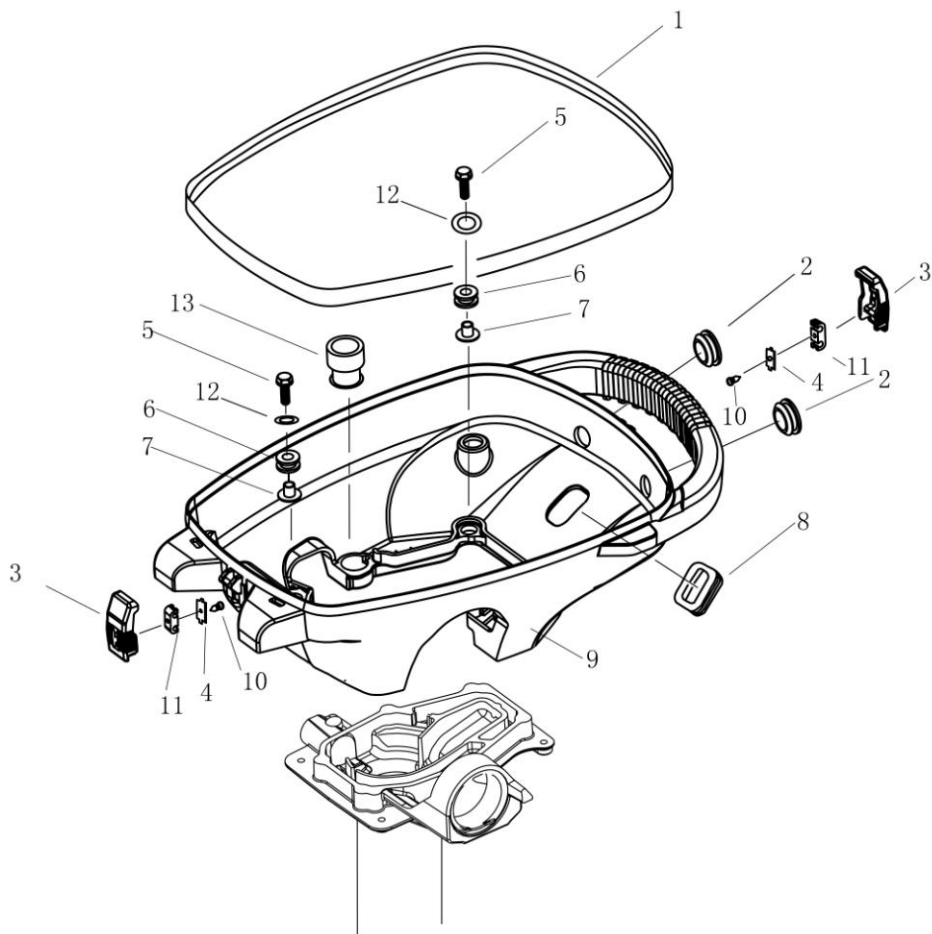

## BOTTOM COWLING

SN.	PART NO.	DESCRIPTION	QTY
1	F2.6-05000002	SEAL, BOTTOM COWLING	1
2	F2.6-05000004	RUBBER PLUG, CIRCULAR	2
3	F2.6-05000008	HOOK, LOCKING	2
4	F2.6-05000010	METALLIC LINK ROD	2
5	GB/T5783-M6X25	BOLT M6X25	4
6	F2.6-05000006	DAMPER	4
7	F2.6-05000007	TUBE FLANGE	4
8	F2.6-05000003	RUBBER PLUG, QUADRATE	1
9	F2.6-05000001A	BOTTOM COWLING	1
10	GB/T845-ST2.9X5	SCREW, TAPPING ST2.9X5	2
11	F2.6-05000009	CONNECTER-ROD	2
12	GB/T96-6	WASHER 6	4
13	F2.6-05000005	RUBBER GROMMET	1



# TOP COWLING

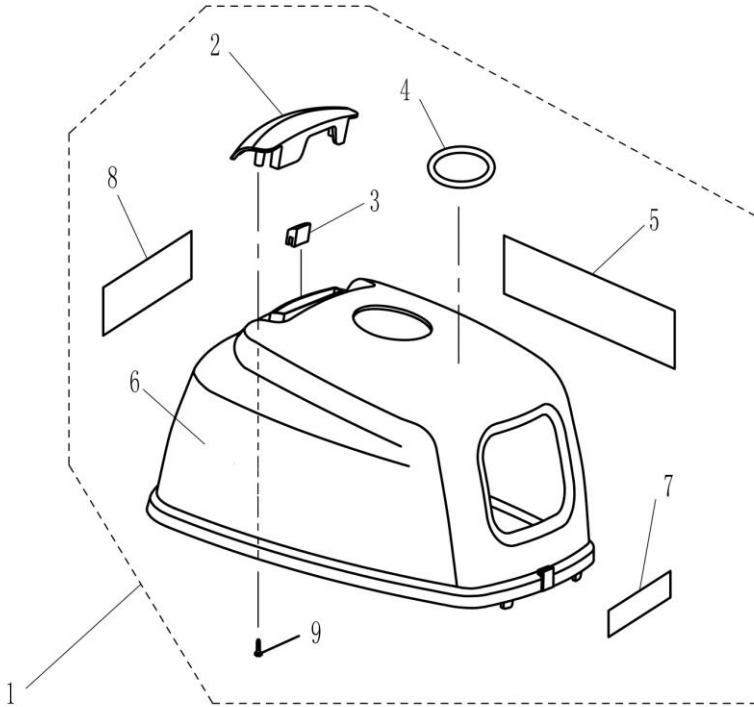

SN.	PART NO.	DESCRIPTION	QTY
1	F2.6-06000001	TOP COWLING	1
2	F2.6-06000002	SILENCER, INTAKE	1
3	F2.6-06000003	DAMPER, INTAKE SILENCER	1
4	F2.6-07000005	MARK 5	1
5	F2.6-07000001	MARK 1	1
6	F2.6-07000002	MARK 2	1
7	F2.6-07000003	MARK 3	1
8	F2.6-07000004	MARK 4	1
9	GB/T845-ST3.8x12	SCREW, TAPPING ST3.8X12	2
10	F2.6-07000000	MARK 1/2/3/4/5	5

# Repair Kit 1

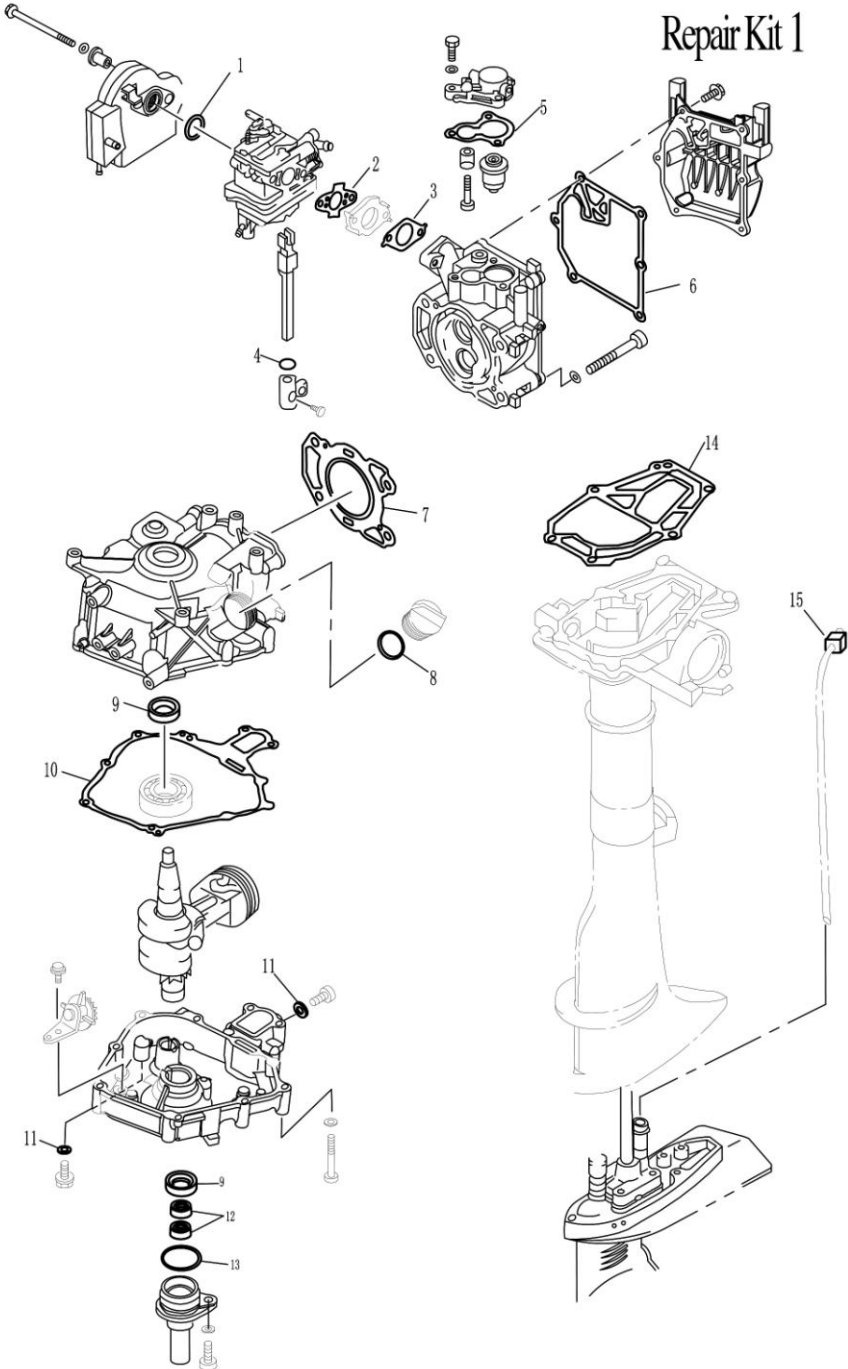

SN.	PART NO.	DESCRIPTION	QTY
1	JASO F404-24-021	O-RING	1
2	F2.6-04000018	GASKET, CARBURETOR AIRPROOF	1
3	F2.6-04000010	GASKET, CARBURETOR AIRPROOF	1
4	JASOF404-24-014	O-RING $\Phi$ 13.8x2.4	1
5	F4-04000011	GASKET, THERMOSTAT	1
6	F2.6-04000005	GASKET, CYLINDER COVER	1
7	F2.6-04000001	GASKET, CYLINDER HEAD	1
8	JASO F404-31-025	O-RING	1
9	F2.6-04010001	OIL SEAL SD 20x30x7 HS	2
10	F2.6-04000004	CRANK CASE COMPLEX GASKET	1
11	F4-04000006	WASHER, PLATE	2
12	F2.6-04060002	OIL SEAL K-5657	2
13	F4-04060002	O-RING	1
14	F2.6-00000003A	GASKET, ENGINE	1
15	F4-02040002	I-SHAPED RUBBER BAND	1

# Repair Kit 2

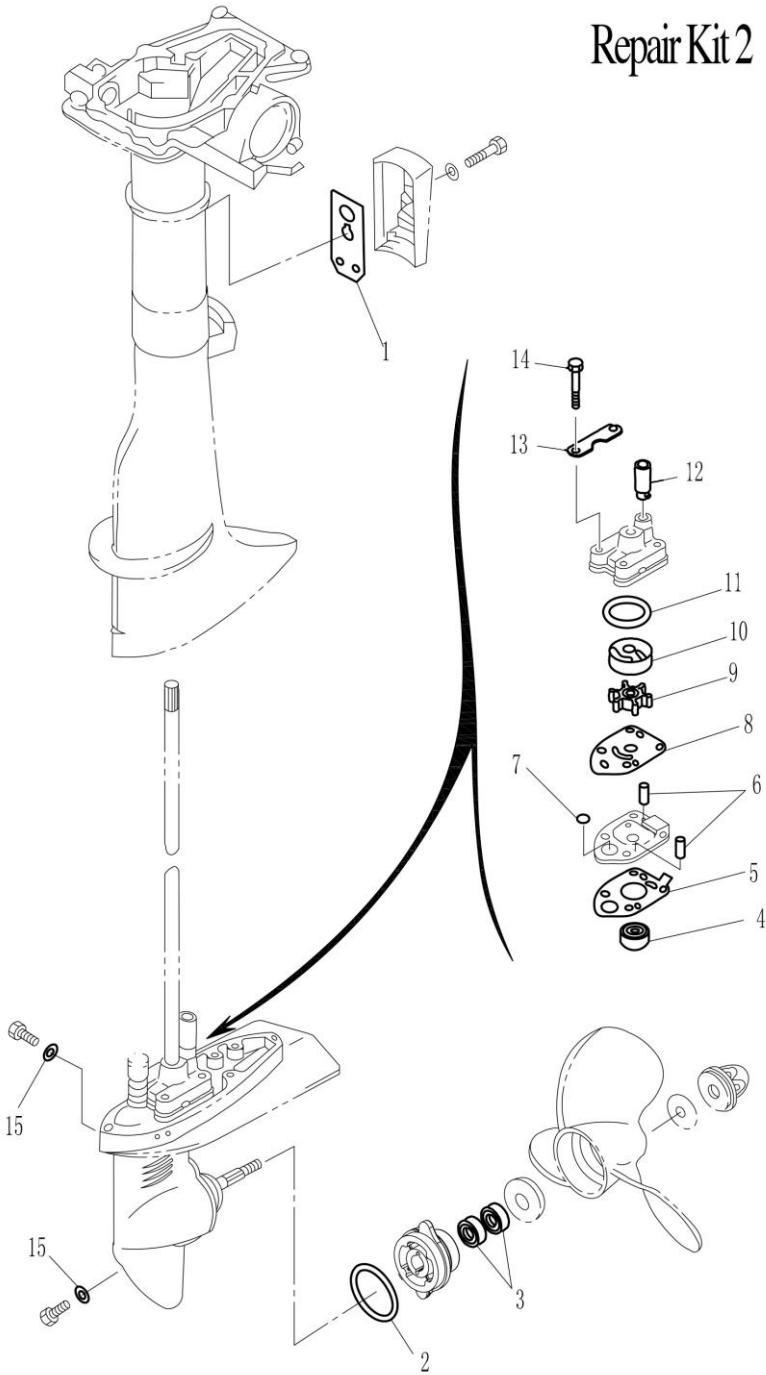

SN.	PART NO.	DESCRIPTION	QTY
1	F2.6-02000005	GASKET, EXHAUST COVER	1
2	JISB 2401-P48	O-RING $\phi 47.7 \times 3.5$	1
3	F4-03050002	OIL SEAL 13x22x7	2
4	F2.6-03000004	OIL SEAL 9.8x24x9	1
5	F2.6-03000007	GASKET, WATER PUMP	1
6	F4-03000013	PIN $\phi 4 \times 18$	2
7	F2.6-03000009	O-RING	1
8	F2.6-03000010	OUT PLATE	1
9	F2.6-03000100	IMPELLER ASSY	1
10	F2.6-03000015	INNER HOUSING, WATER PUMP	1
11	JASO F404-19-033	O-RING	1
12	F4-03000021	RUBBER TUBE, WATER PUMP	1
13	F2.6-03000016	PLATE, WATER PUMP FIXED	2
14	GB/T5783-M6x40	BOLT M6x40	4
15	F4-03000024	GASKET	2

## **EMISSION CONTROL SYSTEM WARRANTY**

### **Buffalo Corp.**

#### **Your Warranty Rights and Obligations**

The California Air Resources Board, The United States Environmental Protection Agency (US EPA) and Buffalo Corp. are pleased to explain the exhaust and evaporative emissions control system warranty on your 2019 model year small off-road engine. In California, new equipment that use small off-road engines must be designed, built, and equipped to meet the State's stringent anti-smog standards. Buffalo Corp. must warrant the emissions control system on your small off-road engine for the periods of time listed below provided there has been no abuse, neglect or improper maintenance of your small off-road engine or equipment leading to the failure of the emissions control system.

Your emissions control system may include parts such as the carburetor or fuel-injection system, the ignition system, catalytic converter, fuel tanks, fuel lines (for liquid fuel and fuel vapors), fuel caps, valves, canisters, filters, clamps and other associated components. Also included may be hoses, belts, connectors, and other emission-related assemblies.

Where a warrantable condition exists, Buffalo Corp. will repair your small off-road engine at no cost to you including diagnosis, parts and labor.

#### **Manufacturer's Warranty Coverage:**

The exhaust and evaporative emissions control system on your small off-road engine is warranted for two years. If any emissions-related part on your small off-road engine is defective, the part will be repaired or replaced by Buffalo Corp.

#### **Owner's Warranty Responsibility**

As the small off-road engine owner, you are responsible for the performance of the required maintenance listed in your owner's manual. Buffalo Corp. recommends that you retain all receipts covering maintenance on your small off-road engine, but Buffalo Corp. cannot deny warranty coverage solely for the lack of receipts or for your failure to ensure the performance of all scheduled maintenance.

As the small off-road engine owner, you should however be aware that Buffalo Corp. may deny you warranty coverage if your small off-road engine or a part has failed due to abuse, neglect, or improper maintenance or unapproved modifications.

You are responsible for presenting your small off-road engine to a Buffalo Corp. distribution center or service center as soon as the problem exists. The warranty repairs shall be completed in a reasonable amount of time, not to exceed 30 days.

If you have any questions regarding your warranty rights and responsibilities, you should contact Buffalo Corp. customer service representative at 1-866-460-9436 or write to [info@buffalotools.com](mailto:info@buffalotools.com).

## **DEFECTS WARRANTY COVERAGE**

Adopted by the Air Resources Board, Buffalo Corp. warrants to the ultimate purchaser and each subsequent purchaser that the small off-road engine (SORE)(1) has been designed, built and equipped so as to conform with all applicable regulations; and (2) is free from defects in materials and workmanship that cause the failure of a warranted part to conform with those regulations as may be applicable to the terms and conditions stated below.

(a) The warranty period begins on the date the engine is delivered to an ultimate purchaser or first placed into service. The warranty period is two years.

(b) Subject to certain conditions and exclusions as stated below, the warranty on emissions related parts is as follows:

(1) Any warranted part that is not scheduled for replacement as required maintenance in your Owner's Manual is warranted for the warranty period stated above. If the part fails during the period of warranty coverage, the part will be repaired or replaced by Buffalo Corp. according to Subsection (4) below. Any such part repaired or replaced under warranty will be warranted for the remainder of the periods.

(2) Any warranted part that is scheduled only for regular inspection in your owner's manual is warranted for the warranty period stated above. Any such part repaired or replaced under warranty will be warranted for the remaining warranty period.

(3) Any warranted part that is scheduled for replacement as required maintenance in your owner's manual is warranted for the period of time before the first scheduled replacement date for that part. If the part fails before the first scheduled replacement, the part will be repaired or replaced by Buffalo Corp. according to Subsection (4) below. Any such part repaired or replaced under warranty will be warranted for the remainder of the period prior to the first scheduled replacement point for the part.

(4) Repair or replacement of any warranted part under the warranty provisions herein must be performed at a warranty station at no charge to the owner.

(5) Notwithstanding the provisions herein, warranty services or repair will be provided at all of our distribution centers that are franchised to service the subject engines.

(6) The engine owner must not be charged for diagnostic labor that leads to the determination that a warranted part is in fact defective, provided that such diagnostic work is performed at a warranty station.

(7) Buffalo Corp. is liable for damages to other engine components proximately caused by a failure under warranty of any warranted part.

(8) Throughout the engine warranty period stated above, Buffalo Corp. will maintain a supply of warranted part sufficient to meet the expected demand for such parts.

(9) Any replacement may be used in the performance of any warranty maintenance or repairs and must be provided without charge to the owner. Such use will not reduce the warranty obligations of Buffalo Corp.

(10) Add-on or modified parts that are not exempted by the Air Resources Board may not be used. The use of any non-exempted add-on or modified parts by the ultimate purchaser will be grounds for disallowing a warranty claims. Buffalo Corp. will not be liable to warrant failures of warranted parts caused by the use of a non-exempted add-on or modified part.

(11) The manufacturer issuing the warranty shall provide any documents that describe that manufacturer's warranty procedures or policies within five working days of request by the Air Resources Board.

## **EMISSION WARRANTY PARTS LIST**

### Fuel Metering System:

Gasoline carburetor assembly and its internal components

Carburetor gaskets (c) fuel lines (for liquid fuel and fuel vapors)

(d) Clamps (e) Fuel tank

(f) Fuel line fittings (g) Pressure regulator (if equipped)

(h) Mixer assembly and its internal components (if equipped)

Air induction system including:

Intake pipe/manifold (b) Air cleaner

Ignition system including:

Spark plug (b) Ignition coil

Catalytic muffler assembly including: (b) Exhaust manifold

Muffler gasket

(c) Catalytic converter

Crankcase breather assembly including:

Breather connection tube

(6) Fuel tank evaporative emissions control system including:

(a) Purge valves (b) Fuel cap

Fuel tank (d) fuel lines (for liquid fuel and fuel vapors)

Miscellaneous items used in above systems including:

Switches (b) Hoses, belts connectors and assemblies

Air injection system

Pulse valve

Please Note:

For this warranty, Buffalo Corp. shall warrant the Evaporative and Exhaust combined emission control system on your products.