

## ASSEMBLY INSTRUCTIONS

1. Line up holes on the bracket of wheel assembly (O) with the corresponding holes on base (M), then insert M8 x 16 mm bolts (BB) through holes. Tighten with M8 flange nuts (AA). Be sure the wheel assembly (O) is parallel to the base (M).

Note: To improve stability, the preassembled bucket (N) can be filled with sand (not included). Open the lid, fill sand then close it.

### Hardware Used

**AA** M8 Flange Nut  x 2

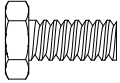
**BB** M8 x 16 mm Bolts  x 2

2. Attach cylinder housing (H) loosely to base (M) with M5 x 8 mm screws (CC).

### Hardware Used

**CC** M5 x 8 mm Screw  x 4

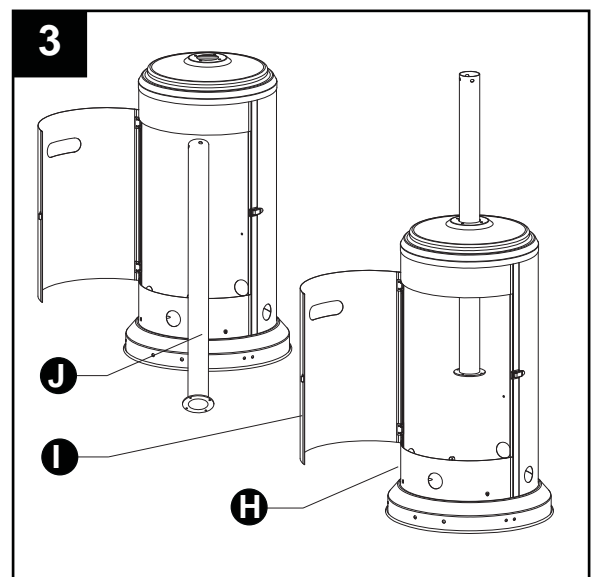
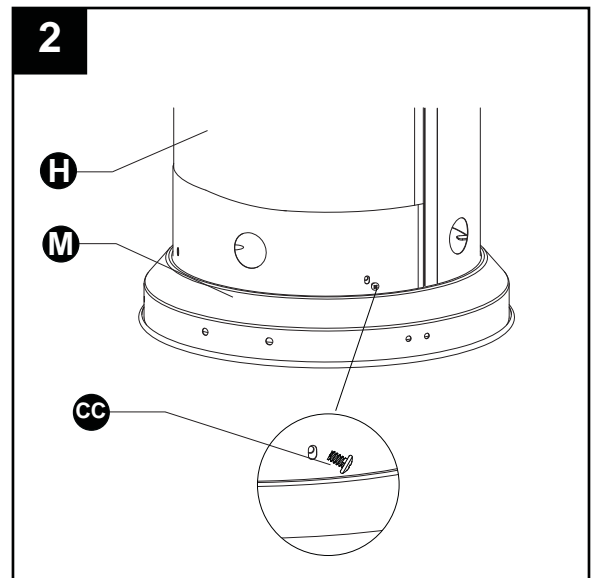
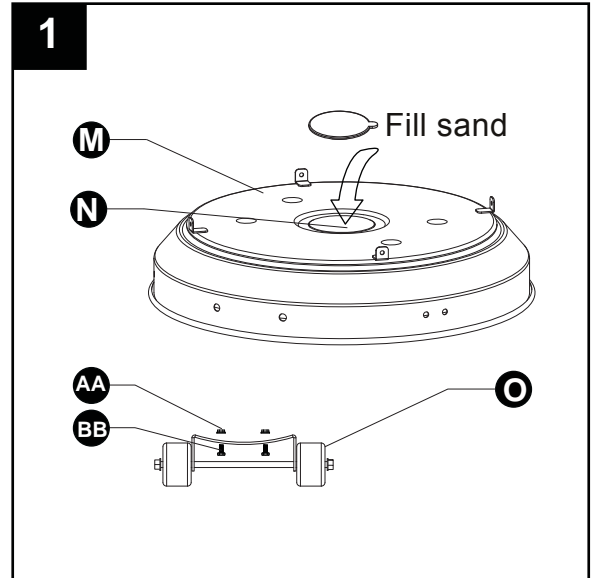

3. Open the preassembled door (I) on cylinder housing (H) and place post (J) through the hole on the top.



## ASSEMBLY INSTRUCTIONS

4. Secure post (J) to cylinder housing (H) using the reinforced ring (NN), M6 x 10 mm bolts (DD) and  $\Phi 6$  small flat washers (EE). Fasten and cover with the deck ring (OO).

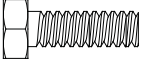
### Hardware Used

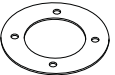
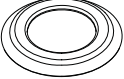
<b>DD</b>	M6 x 10 mm Bolt		x 4
<b>EE</b>	$\Phi 6$ Small Flat Washer		x 4
<b>NN</b>	Reinforced Ring		x 1
<b>OO</b>	Deck Ring		x 1

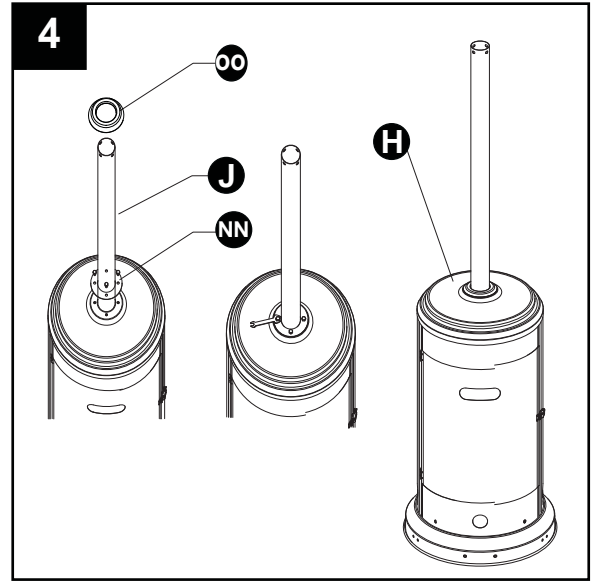

5. Slide fastening nut (G) down the post (J) with the rounded side facing down. Next, slide the tightening spacer (F) down the post (J) with the smaller side facing down. Put the table (E) on the post (J) with the metallic side facing up.

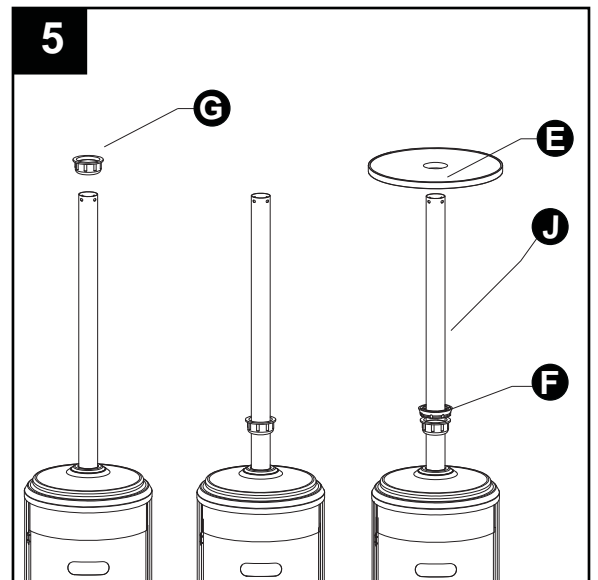

6. Insert the screw coupler (D) on the post (J), inserting it through the middle of the table (E) on the post (J). Thread the tightening spacer (F) on the bottom of the table (E) counterclockwise onto the screw coupler (D). Tighten securely to hold the table (E) to the screw coupler (D). Thread the fastening nut (G) counterclockwise. Tighten securely to lock in place. Loosen the fastening nut (G) to adjust the position of the table (E) on the post (J).

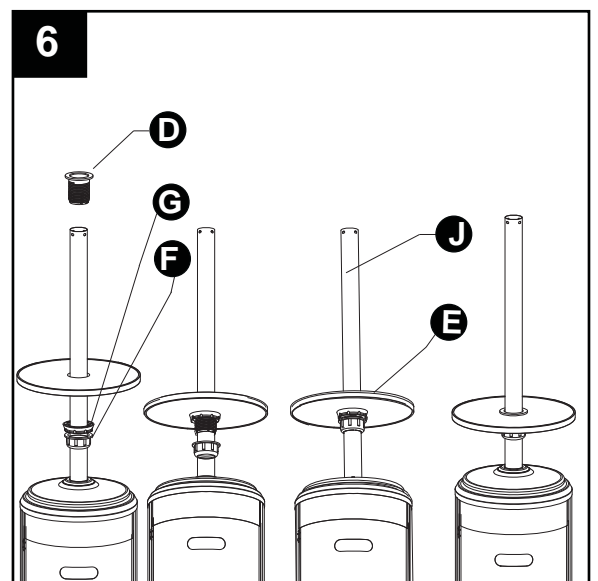

## ASSEMBLY INSTRUCTIONS

7. Attach reflector spacers (FF) and Ø8 washers (GG) to the top of head assembly (C). Tighten the reflector spacers (FF).

### Hardware Used

**FF** Reflector Spacer  x 3

**GG** Ø8 Washer  x 3

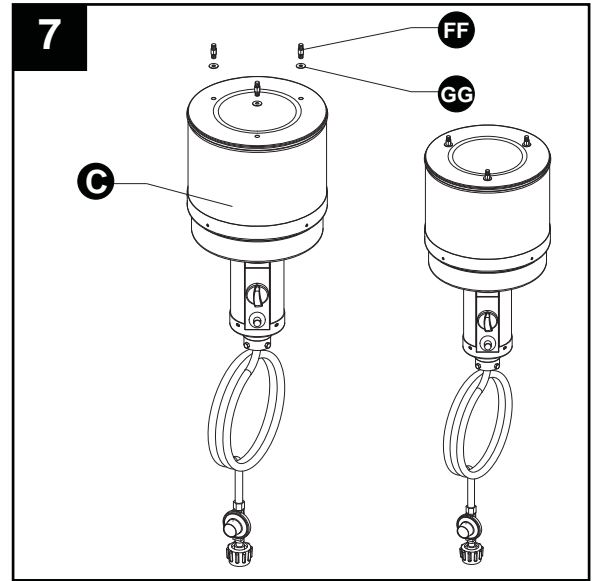

8. Unscrew stainless steel bolts (LL) from head assembly (C).

### Hardware Used

**LL** Stainless Steel Bolt  x 4

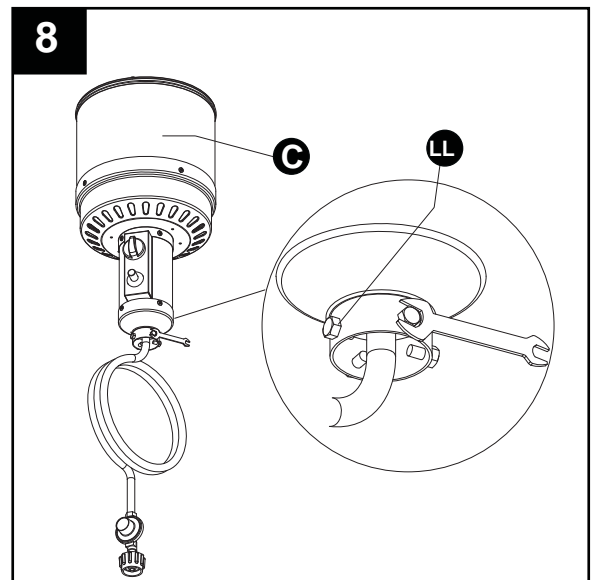

9. Insert hose of head assembly (C) into post (J). Secure head assembly (C) to post (J) with stainless steel bolts (LL).

Note: The control knob on head assembly (C) should be above the decal on post (J).

### Hardware Used

**LL** Stainless Steel Bolt  x 4

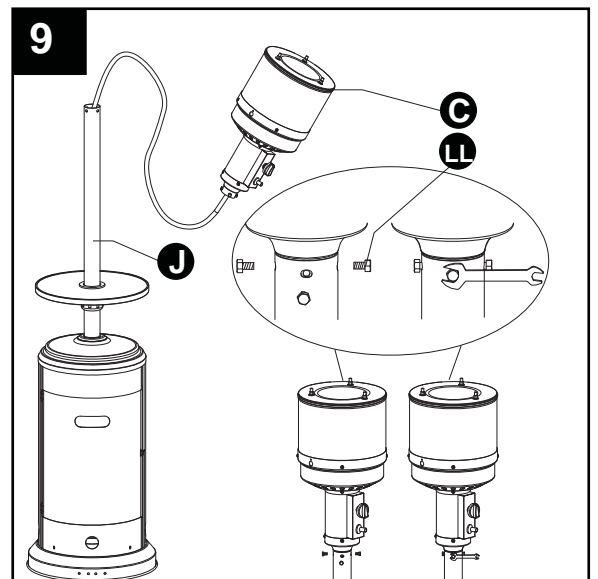

## ASSEMBLY INSTRUCTIONS

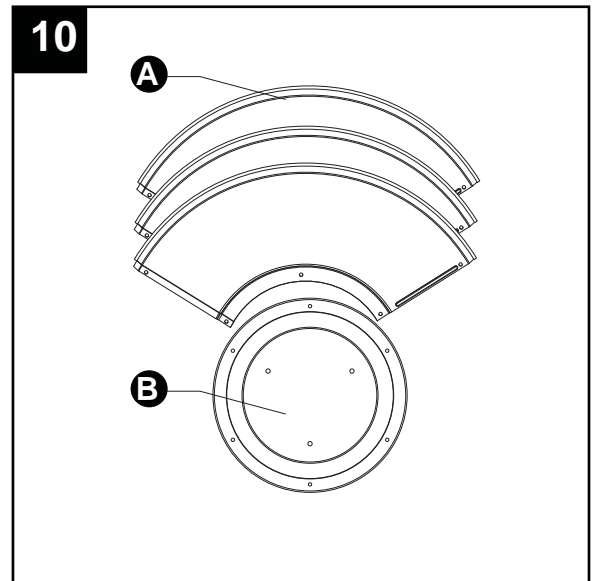

10. Remove protective cover from reflector panel (A) and reflector plate (B).

Note: In order to achieve proper alignment of reflector sections, it may be necessary to loosen the preassembled bolts prior to assembly and retighten once complete.



11. Attach reflector panels (A) together using M6 x 10 mm screws (II) and  $\Phi 6$  washers (HH). Secure loosely with cap nuts (JJ).

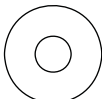
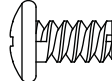

### Hardware Used

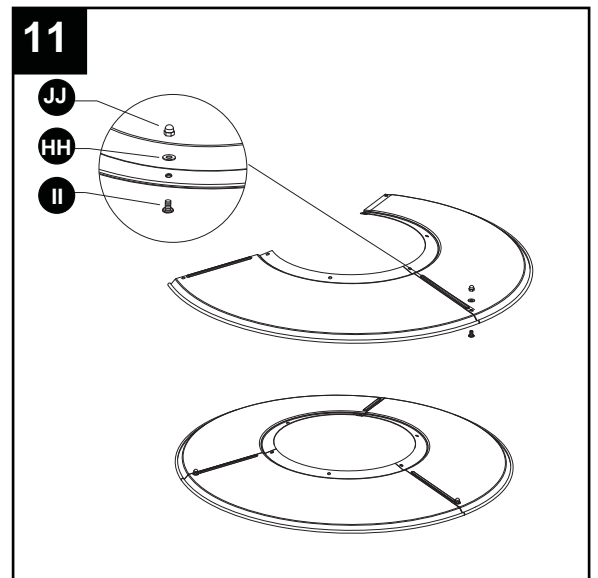
<b>HH</b>	$\Phi 6$ Washer		x 3
<b>II</b>	M6 X 10 mm Screw		x 3
<b>JJ</b>	Cap Nut		x 3

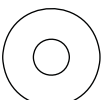
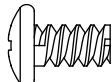

12. Attach reflector plate (B) to reflector panels (A) using M6 x 10 mm screws (II) and  $\Phi 6$  washers (HH). Secure loosely with cap nuts (JJ). Once properly aligned, tighten all screws and the preassembled bolts.

### Hardware Used

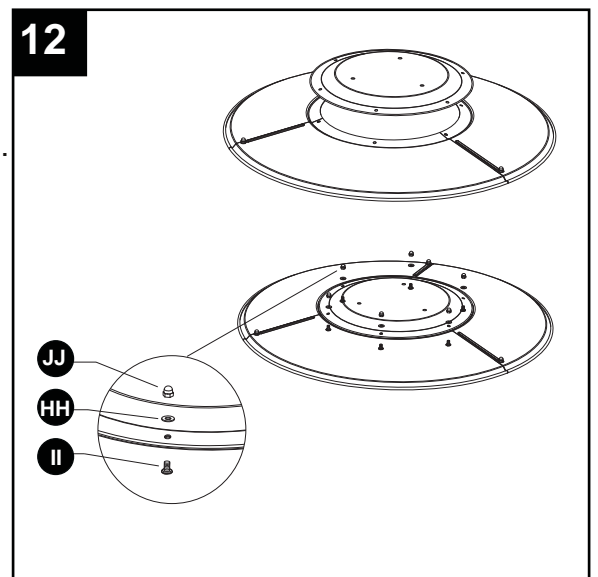

<b>HH</b>	$\Phi 6$ Washer		x 6
<b>II</b>	M6 X 10 mm Screw		x 6
<b>JJ</b>	Cap Nut		x 6



## ASSEMBLY INSTRUCTIONS

13. Slide  $\Phi 8$  washers (GG) over the threaded ends of reflector spacers (FF). Attach reflector assembly to head assembly (C). Place  $\Phi 8$  washers (GG) over threaded ends of reflector spacers (FF) sticking out through reflector assembly and secure with wing nuts (KK).  
Note: Do not overtighten.

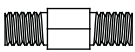
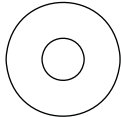
### Hardware Used

<b>FF</b>	Reflector Spacer		x 3
<b>GG</b>	$\Phi 8$ Washer		x 6
<b>KK</b>	Wing Nut		x 3

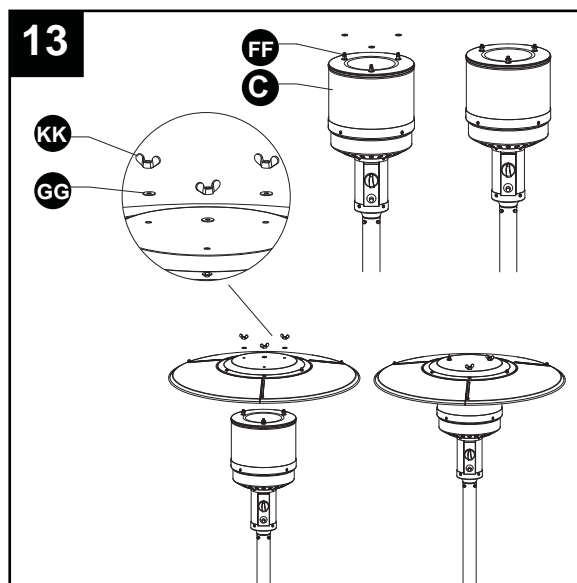

14. Screw gas hose (K) and regulator (L) onto propane cylinder (not included). Do not cross-thread. Place the propane cylinder into the cylinder housing (H), then close the door (I).

**⚠ WARNING:** Use a standard 20 lb. propane cylinder only.

Use this heater only with a propane vapor withdrawal supply system. See chapter 5 of the standard for storage and handling of liquefied petroleum gas, ANS/NFPA 58. Your local library or fire department should have this book.

A minimum supply pressure of 8" W.C. is required for the purpose of input adjustment for propane gas. Storage of an appliance indoors is permissible only if the cylinder is disconnected and removed from the appliance. A cylinder must be stored outdoors in a well-ventilated area out of the reach of children. A disconnected cylinder must have dust caps tightly installed and must not be stored in a building, garage or any other enclosed area. The minimum permissible gas supply pressure of 8" W.C. is required for purpose of input adjustment. A minimum of 17,000 BTUs per hour is the required input rating for a heater with a rating less than full.

The pressure regulator and hose assembly supplied with the appliance must be used.

The installation must conform with local codes, or in the absence of local codes, with national fuel gas code, ANS Z223.1/NFPA54, natural gas and propane Installation Code, CSA B149.1, or propane storage and handling code, B149.2.

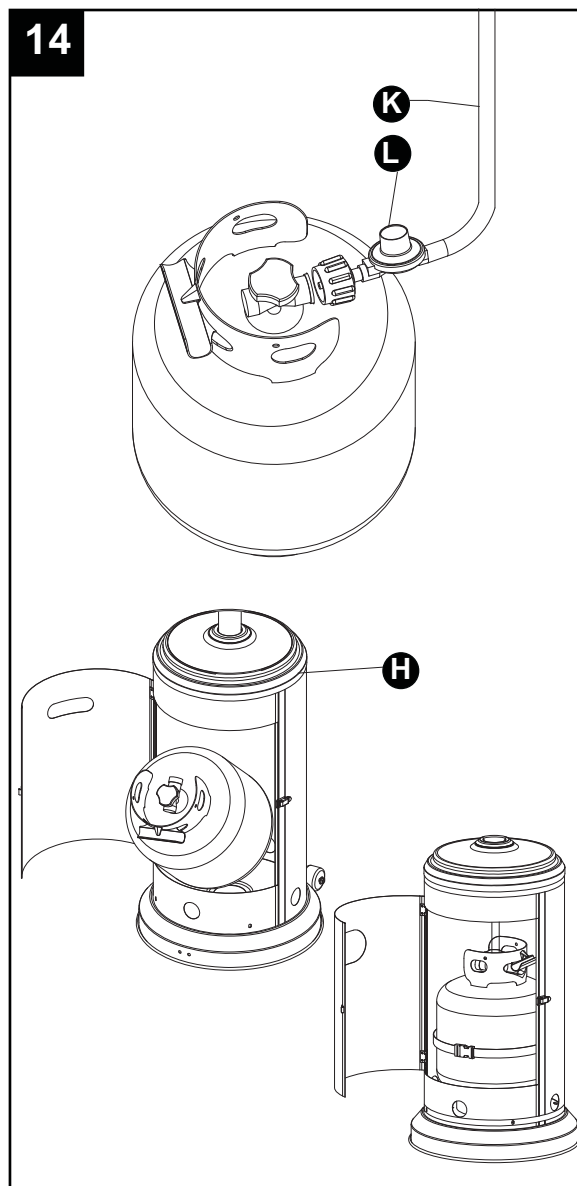

## ASSEMBLY INSTRUCTIONS

---

### **⚠ WARNING:**

A dented, rusted or damaged propane cylinder may be hazardous and should be checked by your propane supplier. Never use a propane cylinder with a damaged valve connection.

The propane cylinder must be constructed and marked in accordance with the specifications for LP gas cylinders of the U.S. Department of Transportation (DOT) or the standard for cylinders, spheres and tubes for transportation of dangerous goods and commission, CAN/CSA-B339.

The cylinder must have a listed overfilling prevention device.

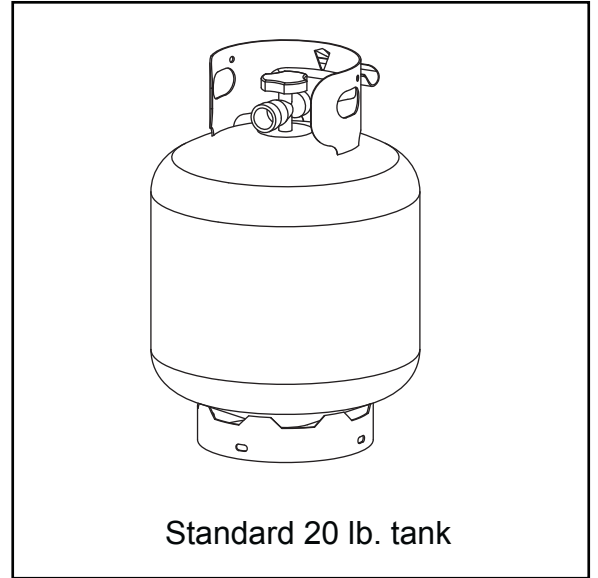

The cylinder must have a connection device compatible with the connection for the appliance.

The cylinder used must include a collar to protect the cylinder valve.

Never connect an unregulated propane cylinder to the heater.

- Do not store a spare LP-gas cylinder under or near this appliance.
- Never fill the cylinder beyond 80 percent full.
- Place the dust cap on the cylinder valve outlet whenever the cylinder is not in use. Only install the type of dust cap on the cylinder valve that is provided with the cylinder valve. Other type of caps or plugs may result in leakage of propane.