

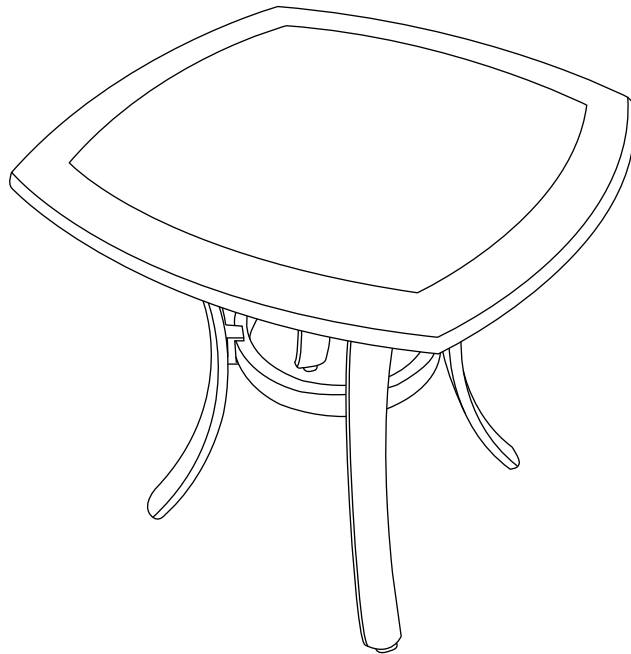

Model #151-007-20ET

USE AND CARE GUIDE

WESTIN 20in. ROUND SQUARE GLASS TOP SIDE TABLE



Questions, problems, missing parts? Before returning to the store,
call Hampton Bay Customer Service
8.00 a.m. - 6.00 p.m., EST, Monday - Friday

1-855-HD-HAMPTON

HAMPTONBAY.COM

THANK YOU

We appreciate the trust and confidence you have placed in Hampton Bay through the purchase of this side table. We strive to continually create quality products designed to enhance your home. Visit us online to see our full line of products available for your home improvement needs. Thank you for choosing Hampton Bay!

Table of Contents

Table of Contents.....	2	Pre-Assembly.....	3
Safety Information.....	2	Planning Assembly.....	3
Warranty.....	2	Hardware Included.....	3
2 Year Frame Limited Warranty.....	2	Package Contents.....	4
What Is Covered.....	2	Assembly.....	5
What Is Not Covered.....	2		
Care Instructions.....	2		

Safety Information

 **DANGER:** Please keep children out of the assembly area during assembly.

 **CAUTION:** Use the table on flat ground only.

 **WARNING:** Do not sit or stand on the table.

 **IMPORTANT:** Please check the tightness of bolts at least every 180 days.

 **WARNING:** Do not put heavy objects on the table.

Warranty

TWO YEAR FRAME LIMITED WARRANTY

WHAT IS COVERED

We warrant the frame to be free of manufacturing defects to the original purchaser for two years.

WHAT IS NOT COVERED

It remains the customer's responsibility for freight and packaging charges to and from our service center. This warranty does not cover commercial use, hardware, acts of nature, fire, freezing and abusive use. In addition, purchased parts are not covered under this warranty. We reserve the right to make substitutions with similar merchandise, if the model in question is no longer in production.

Care Instructions

Before using, wipe with a clean, dry cloth. Do not use bleach or solvents. Treat frame with one-step liquid wax for maximum protection against UV light and salty, damp air. When not in use, store furniture in a cool, dry place. When cleaning the tabletop make sure to use a soft, clean cloth that doesn't bleed color as well.

You may contact our customer service department with any questions by phone at 1-855-HD-HAMPTON or visit www.hamptonbay.com.

Pre-Assembly

PLANNING ASSEMBLY

It will take 2 people about 10 minutes to complete the assembly process.

HARDWARE INCLUDED



NOTE: Hardware not shown to actual size.



— AA



— BB



— CC



— DD



— EE

Part	Description	Quantity
AA	Bolt (M6x15)	4
BB	Bolt (M6x25)	4
CC	Washer	8
DD	Bolt cap	8
EE	Hex wrench	1

Pre-Assembly (continued)

PACKAGE CONTENTS

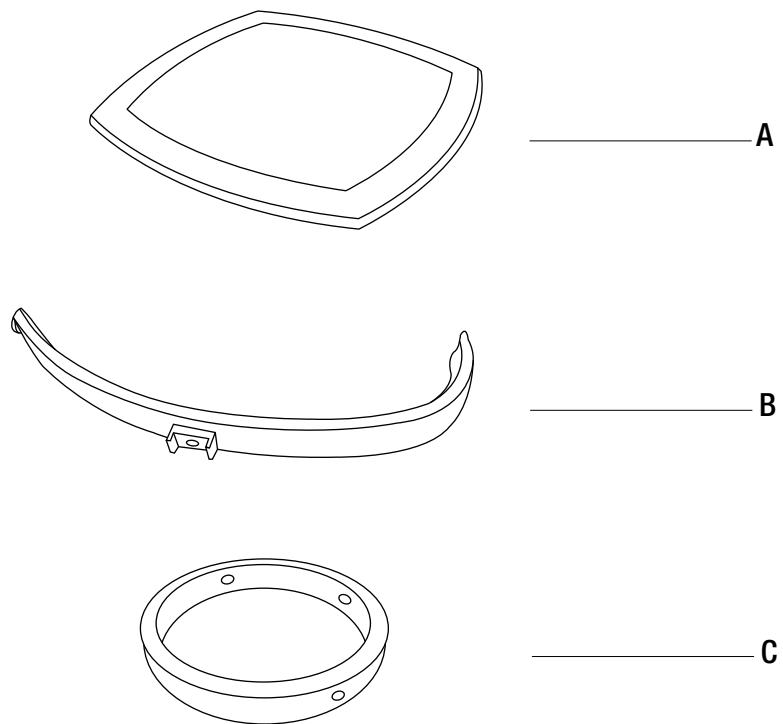

Part	Description	Quantity
A	Table top	1
B	Table leg	4
C	Leg connector bracket	1

Assembly

1 Assembling the table base

- Attach four table legs (B) to leg connector bracket (C) with washers (CC) and bolts (BB) and to form the base.



IMPORTANT: Hand tighten the bolts (BB) only. Do not fully tighten until the end of step 2.

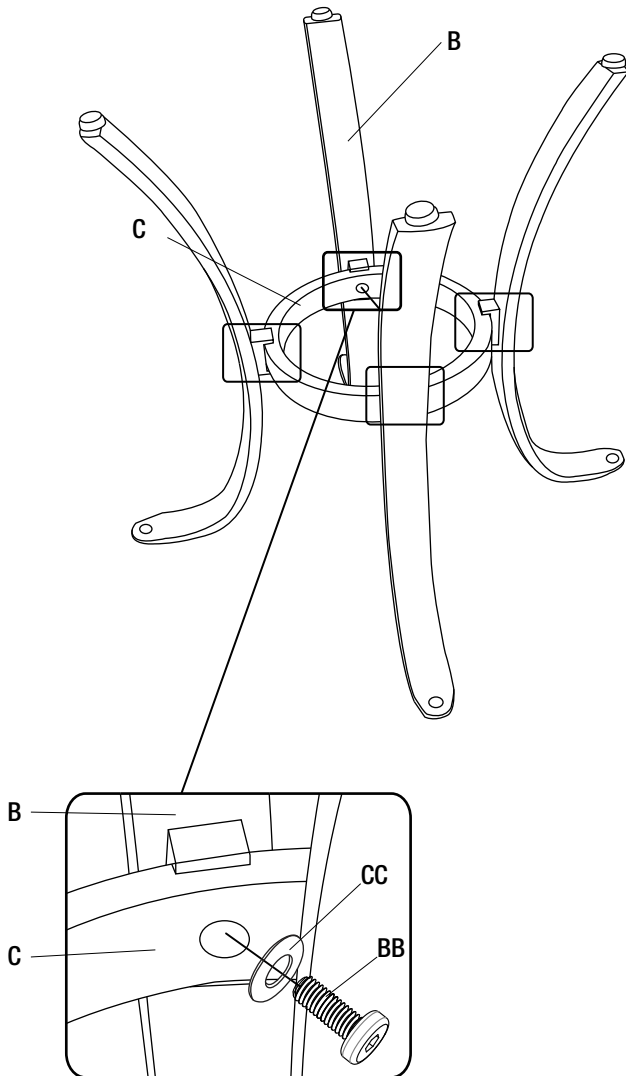

2 Attaching the table base

- Place the table top (A) upside down on a flat, smooth surface.
- Attach table legs (B) to the table top (A) with washers (CC) and bolts (AA).
- Completely tighten all the bolts (AA, BB) using the wrench (EE).

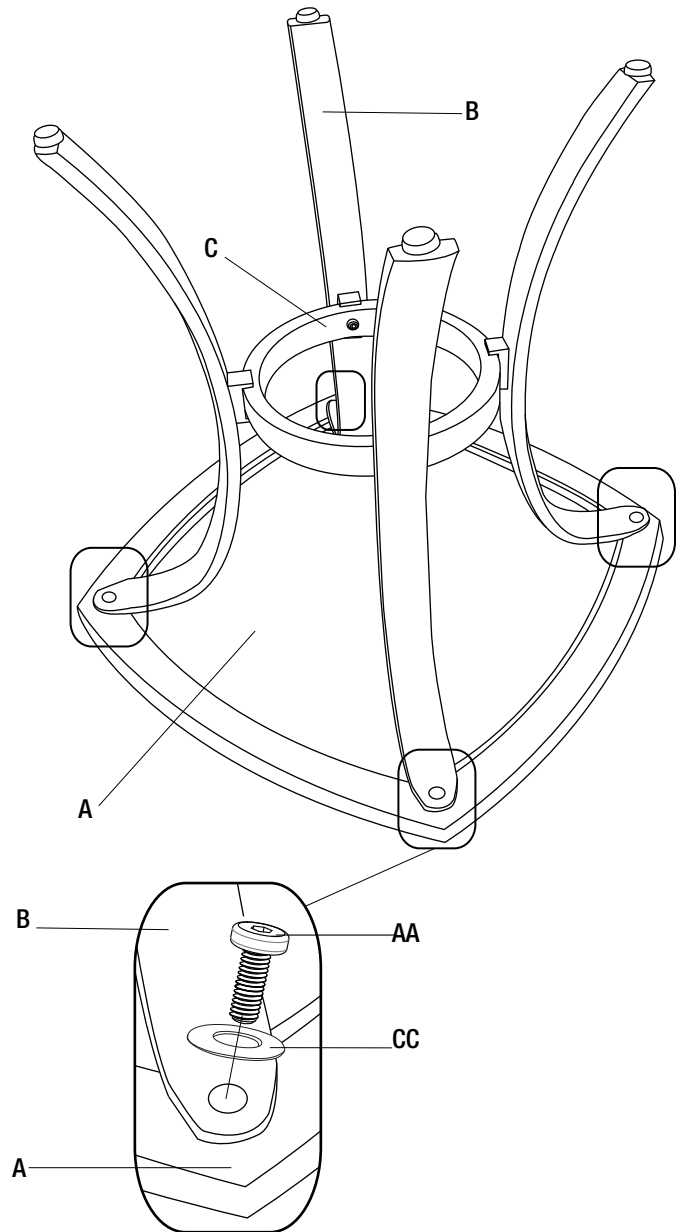

Assembly (continued)

3 Attaching the bolt caps

- Cover all the bolts (AA,BB) with bolt caps (DD).



IMPORTANT: Ensure all the bolts are completely tightened before covering with bolt caps.

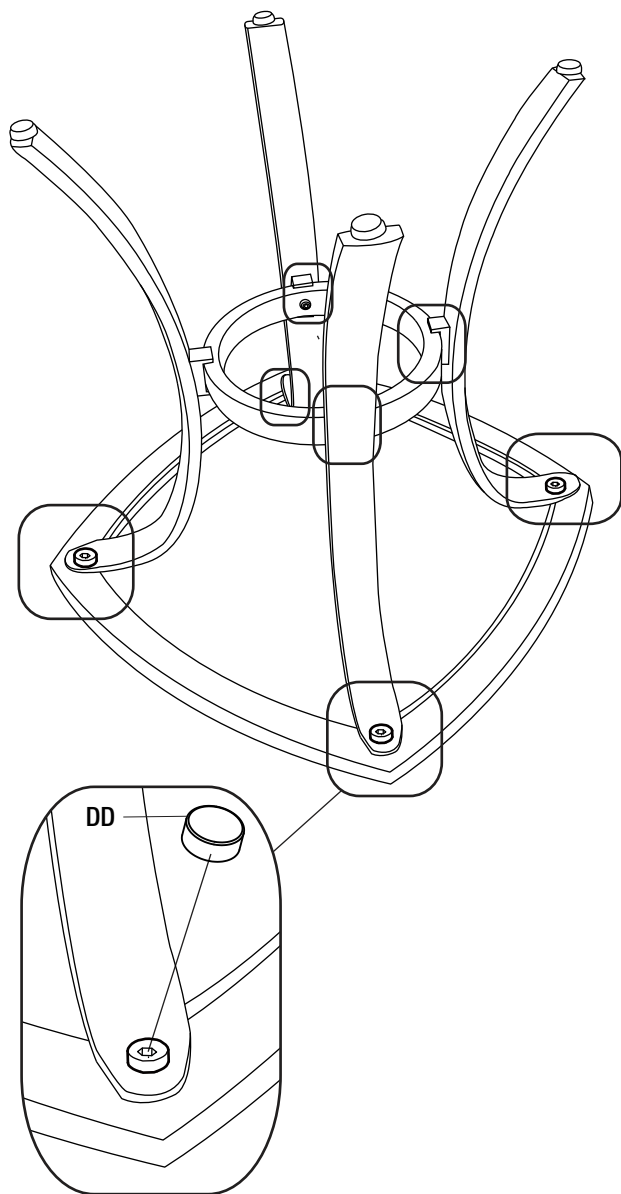

4 Stabilizing the table

- Turn the table upright.

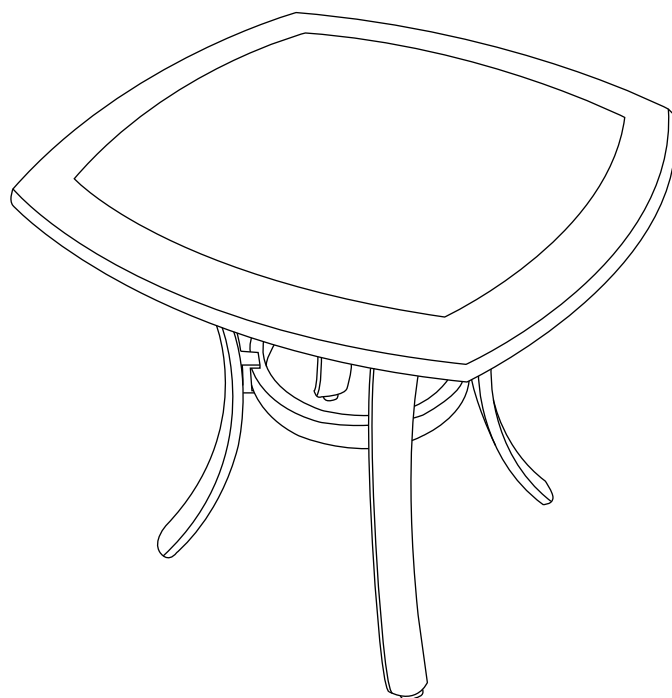



Questions, problems, missing parts? Before returning to the store,
call Hampton Bay Customer Service
8.00 a.m. – 6.00 p.m., EST, Monday-Friday

1-855-HD-HAMPTON

HAMPTONBAY.COM

Retain this manual for future use.