

SPEAKMAN® S-2561

Tiber Arm and Flange

FEATURES:

- Stainless steel shower arm & metal wall flange
- 7 in. length
- 1/2 in. NPTM inlet and outlet

FINISH:



PC

BN

WARRANTY:

- 1 year limited

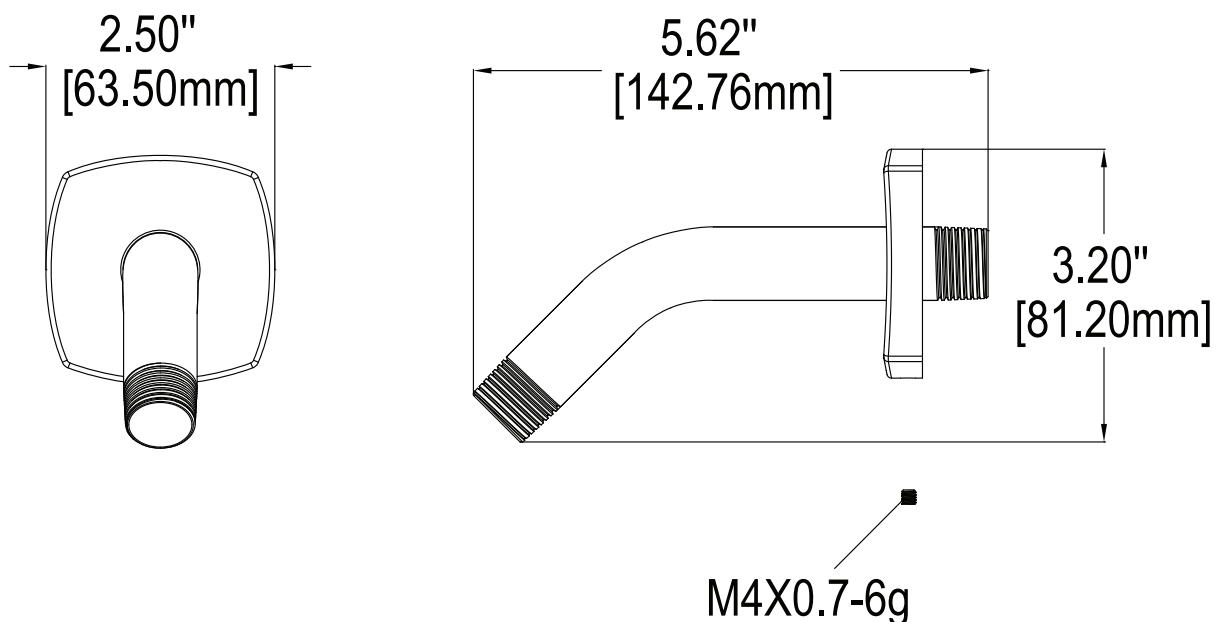

DIMENSIONS:

NOTE: 1. All dimensions are in inches (millimeters) unless otherwise specified and are subject to change without notice.

Architect/Engineer Approval Space:

SPEAKMAN
400 ANCHOR MILL ROAD
NEW CASTLE, DE 19720

P: 800-537-2107
F: 800-977-2747
W: WWW.SPEAKMAN.COM
R: JUNE 2015