

DIY
(Do-It-Yourself)
W-PANEL
PATIO COVER
INSTALLATION
INSTRUCTIONS

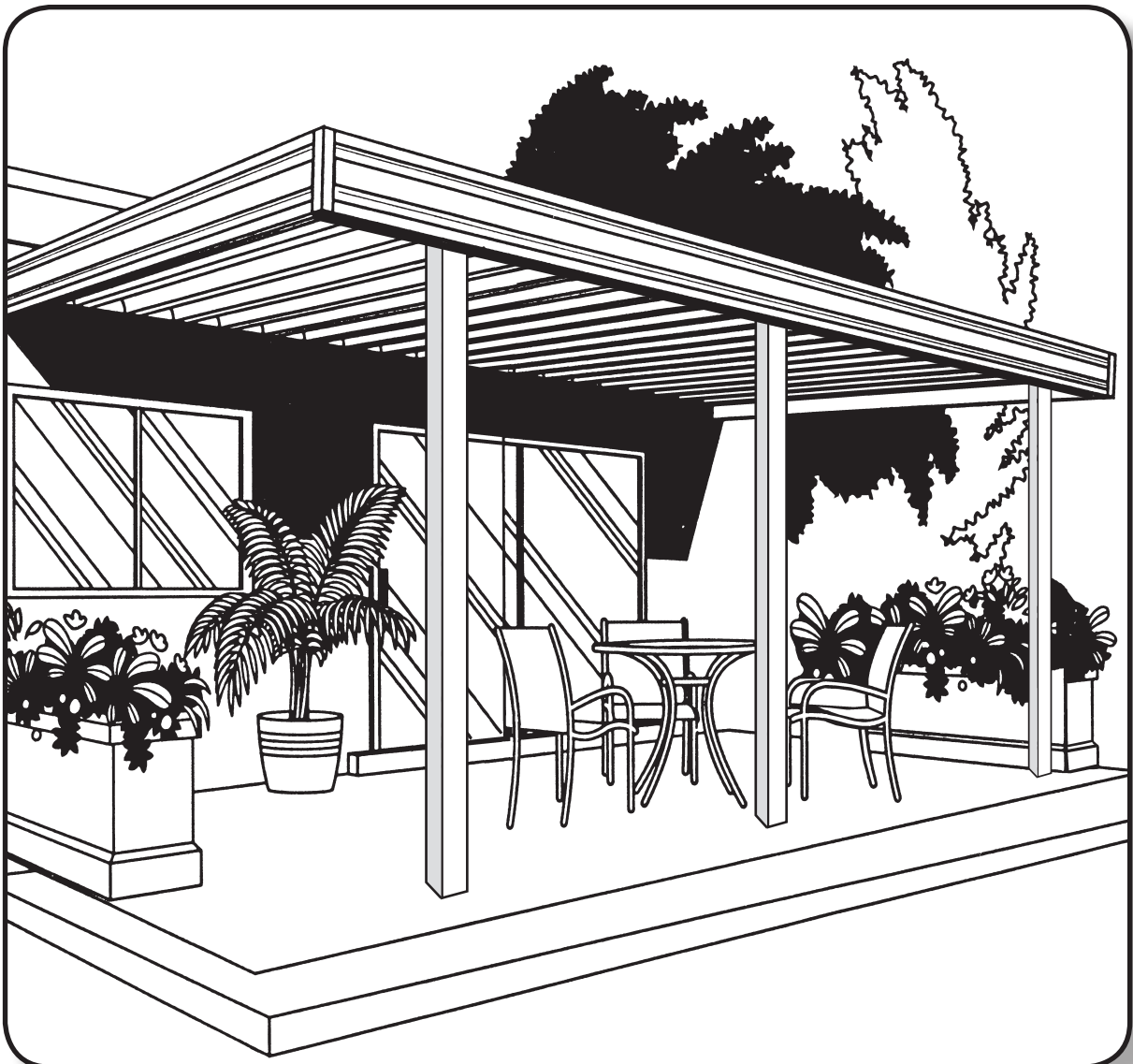

Introduction

Check the contents of carton against the Parts List. This will help you to become familiar with most of the parts on sight. Unpack and layout the parts and identify with component description.









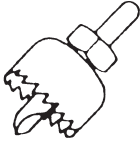
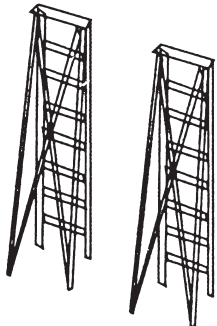

- Inspect all component parts to familiarize yourself with each component.
- The tools recommended (Listed are the basic).
- Before drilling or cutting any component, know its use.
- Refer to the actual sizes of bolts and nuts as you install.
- Before beginning installation, read each instruction step carefully and know the detail involved.
- Determine what type of installation yours is before proceeding, such as, attaching to siding or stucco wall, to roof eaves or attaching to concrete, or brick wall.

ASSEMBLY INSTRUCTIONS:

Read the instructions and study the illustrations carefully. Note location of the various parts and how they are mounted. A diagram of the patio cover shows how the parts of the entire structure fit together. Follow the step by step instructions and your patio cover will go together quickly and accurately.







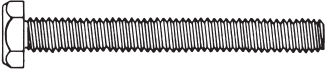

**RETAIN THIS MANUAL AND PARTS LIST AFTER ASSEMBLY
FOR FUTURE REFERENCE.**

TOOLS RECOMMENDED (NOT INCLUDED):

<p style="text-align: center;">LEVEL</p> 	<p style="text-align: center;">CAULKING GUN</p> 	<p style="text-align: center;">HOLE SAW (1-1/2" or 2")</p> 	<p style="text-align: center;">2 STEP LADDERS</p> 
<p>1/4" & 3/8" MASONRY DRILL BIT</p>  <p>1/4" & 3/8" DRILL BIT</p> 	<p style="text-align: center;">3/8" DRILL MOTOR W / EXTEN. CORD</p> 	<p style="text-align: center;">CRESCENT WRENCH</p> 	<p style="text-align: center;">1/4", 5/16", 3/8" SOCKET DRIVE</p> 
<p style="text-align: center;">HAMMER</p> 	<p style="text-align: center;">TAPE MEASURE MAGIC MARKER</p> 		
<p style="text-align: center;">HACK SAW</p> 			

(Before Beginning Installation, Read Each Step Carefully)

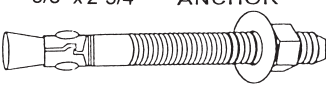
Bolts, Nuts and Screws

 3/8" x 3-1/2" Bolt and Nut (Part 14)		 1/4" x 3/4" Bolt and 1/4" Nut (Part 13)		 Washer (Part 15)		 CAULKING (PART 20)			
 #10 x 3/8" Sheet Metal Screw (Part 16)		 #8 x 5/8" Tek Screw (Self Drilling) (Part 18A)		 1/4" x 3/4" Tek Screw (Self Drilling) (Part 18B)		 3/8" x 2-3/4" ANCHOR (Part 19)		 # 12 x 2-1/2" Screw (Part 17)	

Components and Assembly Instructions

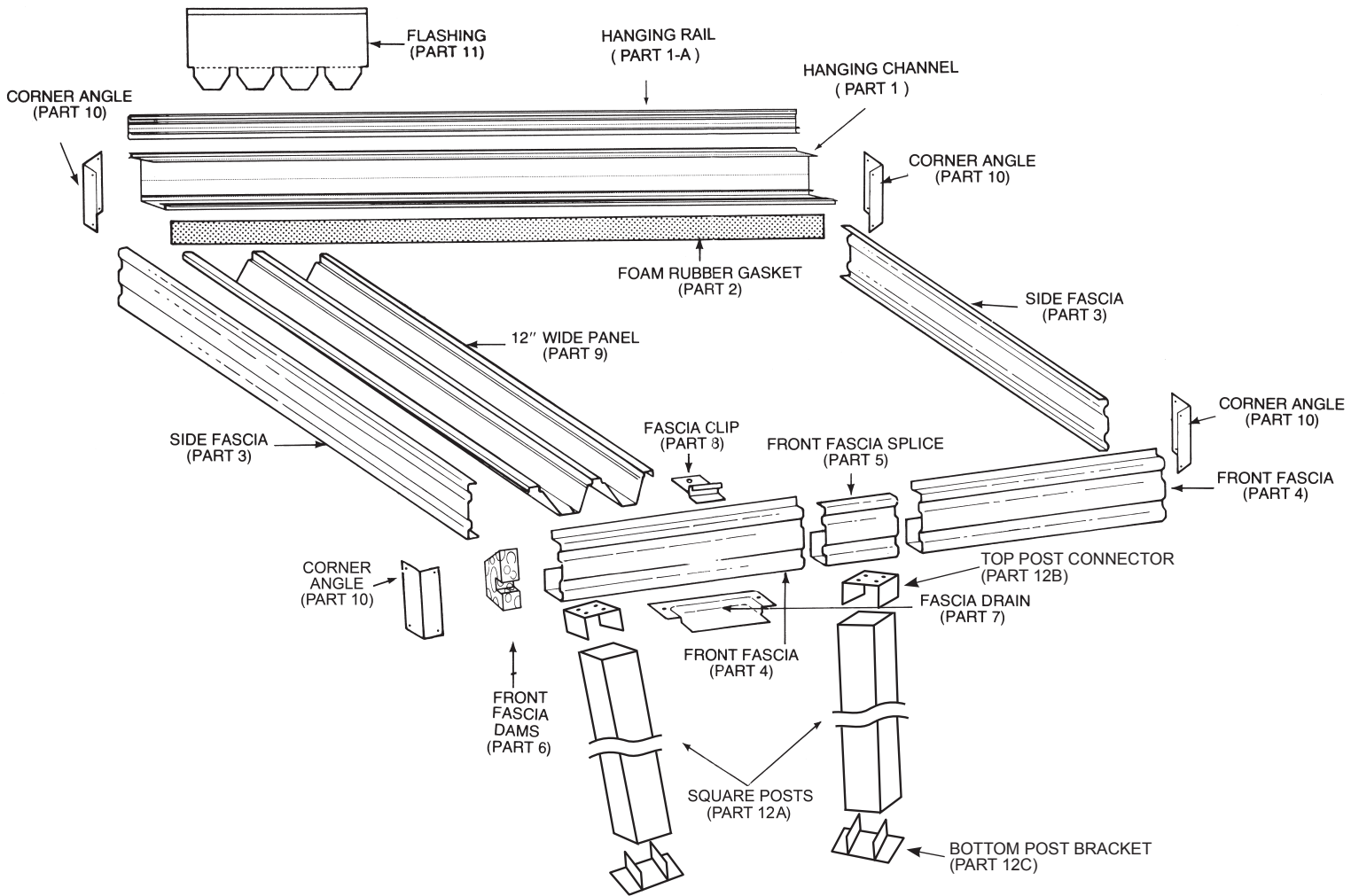

Part No.	Description
1	Hanging Channel
1A	Hanging Rail
2	Foam Rubber Gasket
3	Side Fascia
4	Front Fascia
5	Front Fascia Splice
6	Front Fascia Dams
7	Fascia Drain

Part No.	Description
8	Fascia Clip
9	12" Wide Panel
10	Corner Angle
11	Flashing
12A	Square Post
12B	Top Post Connector
12C	Bottom Post Bracket
13	1/4" x 3/4" Bolt and Nut

Part No.	Description
14	3/8" x 3-1/2" Bolt and Nut
15	1/4" x 3/4" Washer
16	#10 x 3/8" Screw
17	#12 x 2-1/2" Screw
18A	#8 x 5/8" Tek Screw (Self Drilling)
18B	1/4" x 3/4" Tek Screw (Self Drilling)
19	3/8" x 2-3/4" Anchor
20	Caulking

STEP
1

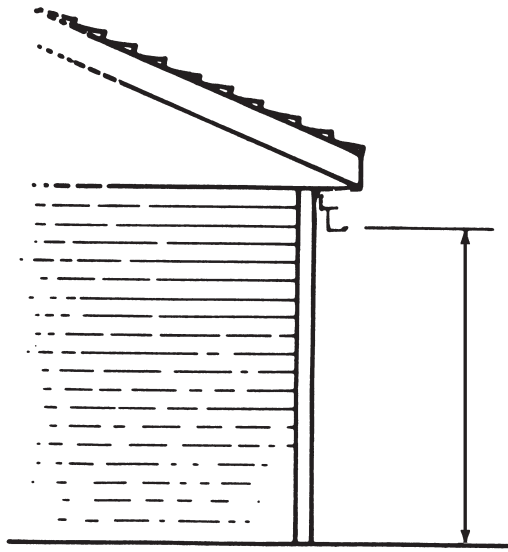
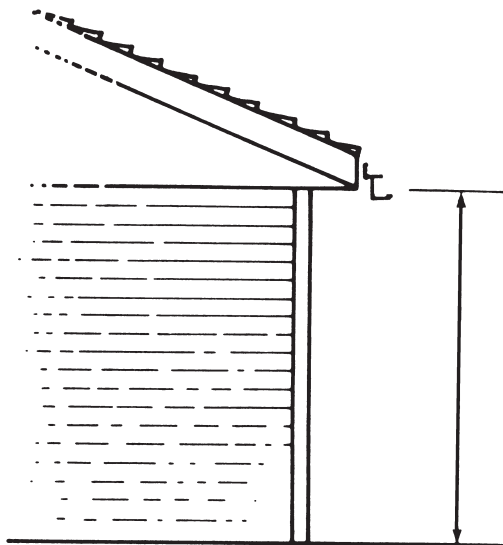

Fig. 1



Patio cover height should clear out swinging doors and windows and finish at a minimum of 6'8" to underside of front fascia.

WARNING:

Before attaching hanging channel to fascia board or wall, you must determine rafter or stud spacing so that attachment screws will drive into each of the above members and provide necessary support for the patio cover. Spacing is usually 16". Masonry installation will require anchor screws purchased locally.

STEP
2

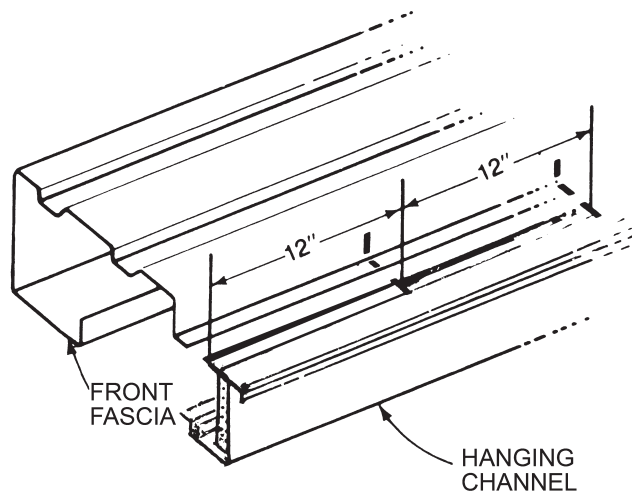

Fig. 2

A. Lay the hanging channel (**Part 1**) on the slab. On wider covers you will have 2 hanging channels. Lay end to end. Place the front fascia (**Part 4**) next to the hanging channel (**Part 1**), on wider covers you will have 2 front fascias. Lay end to end. Mark 12" spaces with a marker. Mark top of front fascia (**Part 4**).

NOTE: Last space will be 12-3/4" to allow for flange width on last panel.
Do not cut the hanging channel.

Those marks will be used later to install the roof panels (**Part 9**) at the proper spacing. (**Fig. 2**).

B. Place hanging rail (s) (**Part 1-A**) in desired position on wall or fascia board and mark first hole to be drilled in hanging rail (s) (**Part 1-A**) relative to rafters or wall studs. (**Fig. 3**).

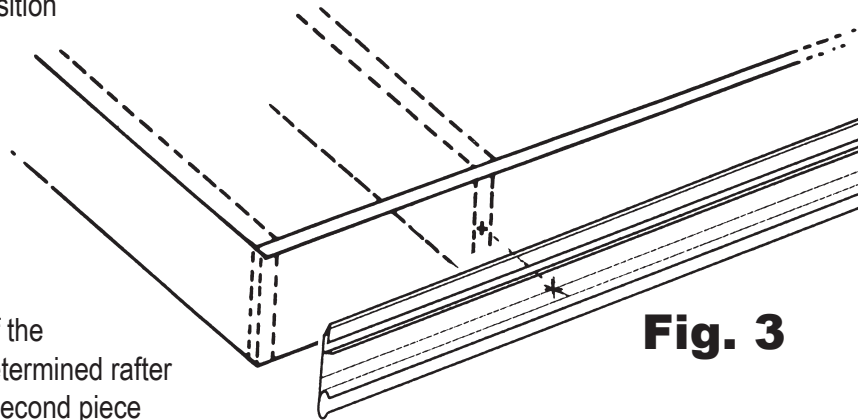

Fig. 3

C. Drill 1/4" hole on mark, 1" down from top of hanging rail. Drill additional holes the length of the hanging rail (**Part 1-A**) based on previously determined rafter or wall stud spacing. Repeat above steps for second piece of hanging channel on wider covers (**Part 1-A**).

D. Slide hanging channel (**Part 1**) into bottom of hanging rail (**Part 1-A**) using a 5/16" socket drive and # 12 x 2-1/2" screws (**Part 17**) fasten the hanging rail(s) to the fascia board or wall. Caulk the top of the hanging rail (**Part 1-A**) (**Fig 4**).

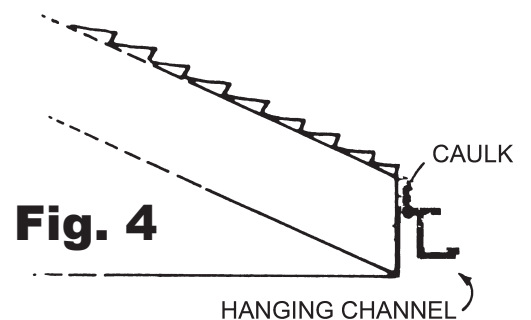

Fig. 4

STEP 3

Prepare Front Fascia

Fig. 6

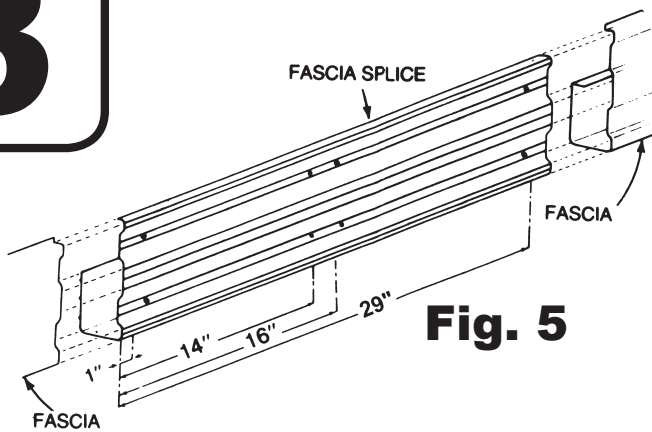

Fig. 5

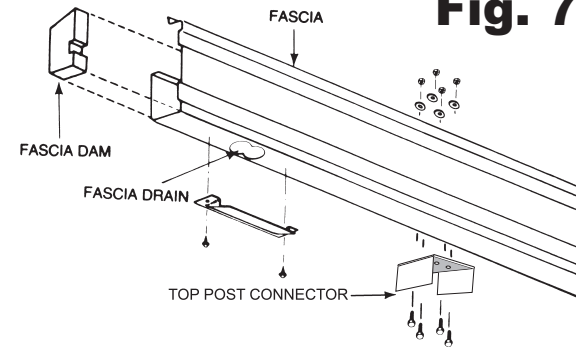

Fig. 7

Skip step A if you have only one (1) Fascia.

A. Splice the two pieces of fascia together.

1. Apply a generous amount of caulking to the inside of the fascia ends to be spliced.
2. Place the splice in the fascia so that its center coincides with the end of the first fascia.
3. Place the second fascia over the other end of the splice.
4. Secure the splice using 3/8" socket drive and twelve 1/4" x 3/4" Tek Screws (Part 18B)
5. Install tek screws (Self Drilling) at 1", 14", 16" and 29" from the end of the splice (eight screws) use (four) additional screws (Part 18B) to attach back leg of fascia to the splice. (Fig. 5)

B. Attaching Top Post Connector (Part 12B) (For max post spacing, see engineering)

1. Using the top post connector as a guide, mark the holes in the connector on the bottom of the fascia (Part 4).
2. Drill 1/4" diameter holes in the bottom side of the fascia (Part 4).
3. Bolt the connector (Part 12B) to the bottom of the fascia (Part 4) using four 1/4" x 3/4" bolts and nuts (Part 13) and washers (Part 15).
4. Generously caulk the inside of the fascia (Part 4) around the protruding bolt heads.

C. Determine fascia drain locations.

1. Using a hole saw, drill a 1-1/2" or 2" diameter hole in the bottom of the fascia, one on each end.
2. Fasten the fascia drain (Part 7) to the bottom of the fascia using the socket drive and two #8 x 5/8" tek screws (Part 18A) per drain. (Fig. 7).

D. Compress and insert fascia dams (Part 6) into each end of the fascia and caulk around them generously.

E. To allow for proper water drainage, a minimum of 1/2" per foot slope is recommended.

- F.** Slide bottom post bracket (Part 12C) up into post, drill two 3/8" diameter holes through both post and bottom bracket. Use two 3/8" x 3-1/2" bolt and nut (Part 14) to fasten. To determine the length of the post (Part 12A), measure the distance from the concrete slab to the bottom of the hanging channel (Part 1). Next, deduct 4" for the back leg of fascia (Part 4) and also deduct the min. 1/2" per foot slope of panel length. The fascia (Part 4) should be level from end to end. (NOTE: If your concrete slab has a slope in it and is not level, the post (Part 12A) will have to be various lengths to compensate for the uneven surface.) Now fasten the square post to the top post connector previously installed on the fascia. Drill two 3/8" diameter holes through both post and post connector. Use two 3/8" x 3-1/2" bolt and nuts (Part 14) to fasten. Raise the assembly into position. Stabilize the assembly with ladders and a rope. (Figure 8).

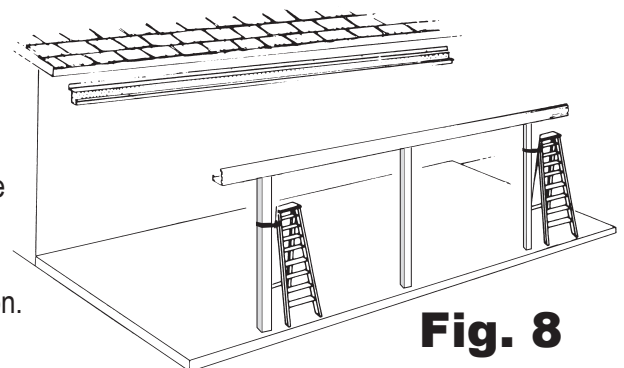
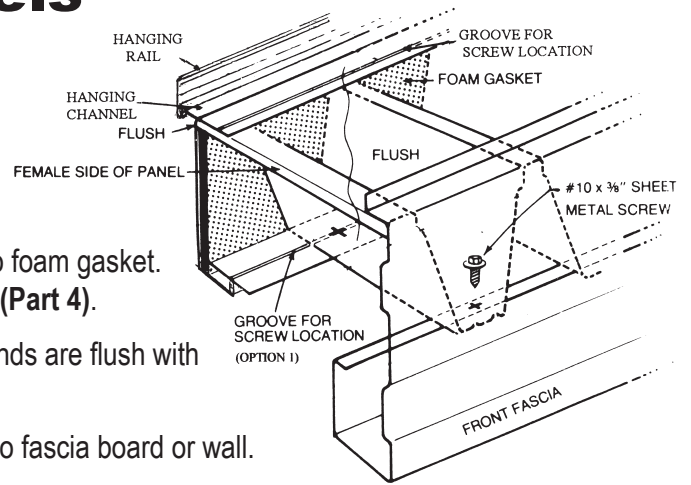

Fig. 8

STEP 4

Install Roof Panels

Fig. 9



- A.** Install first panel as shown in **Fig. 9**. Be sure to press panel into foam gasket. End of panel with prepunched hole attaches to the front fascia (**Part 4**).
- B.** Install last panel in same manner. Be sure male side of panel ends are flush with hanging channel and front fascia. (**Fig. 10**).
- C.** Move fascia assembly side to side so that first panel is square to fascia board or wall.
- D.** Attach square post at ground.

Fig. 10

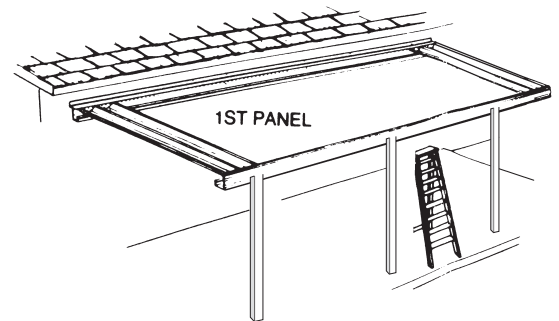

- 1. For surface mounting to top of slab: Mark post position on slab. Insure that post are plumb in both directions. Using the pre-drilled holes in bottom bracket as a guide, mark both holes on slab. Drill 3/8" diameter holes in slab and fasten bottom post bracket to slab with two 3/8" x 2-3/4" anchors.
- E.** Remove sheet metal screw (**Part 16**) from first panel (**Part 9**) the side with the male lock at front fascia (**Part 4**).
- F.** Install second panel as shown (**Fig. 11**) following the directions of the arrows in numerical order.

- G.** You must adjust the interlocking joint between the two panels to align with the 12" marks on the hanging channel and the front fascia. (**Fig. 12**).

- H.** See (**Fig. 11**) and fasten first panel (**Part 9**) at hanging channel (**Part 1**) with # 10 x 3/8" sheet metal screws (**Part 16**). Fasten first panel at front fascia thru prepunched holes into front fascia. (**Fig. 9**).

- I.** Install third panel (**Part 9**) in same manner as second panel (**Part 9**). Fasten second panel (**Part 9**) in same manner as first panel. Caulk panel ends to foam rubber gasket. (**Fig. 11**).

- J.** Install preformed flashing (**Part 11**) into grove on hanging rail (**Part 1-A**). Position over first and second panels (**Part 9**). Bend tabs down so they fit snug to surface of roof panel. Screw flashing (**Part 11**) to peaks of Roof panels (**Part 9**) using # 10 x 3/8" sheet metal screws (**Part 16**). Caulk (**Part 20**) the top of screw heads. (**Fig. 13**).

- K.** Repeat above steps until last panel is reached. Remove the last panel and fasten as previously described.

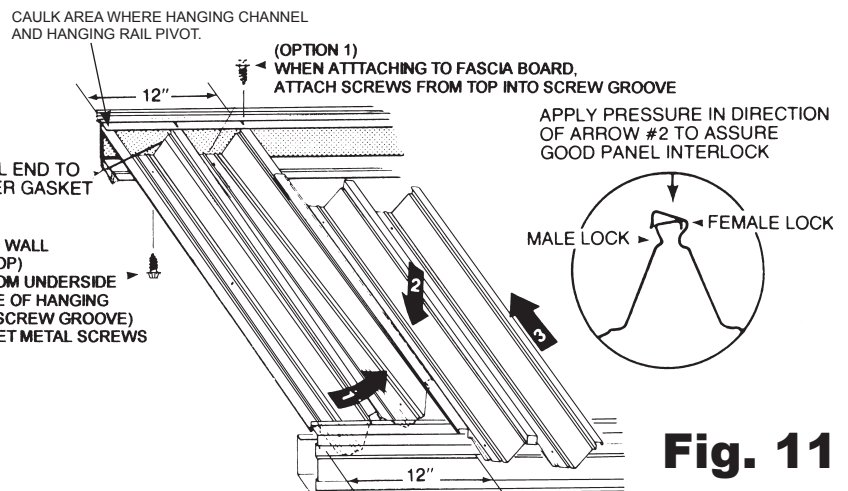

Fig. 11

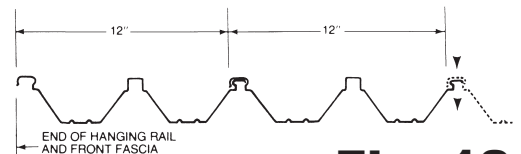
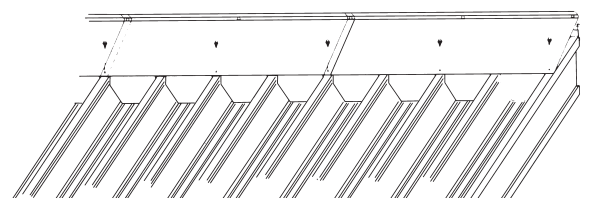

Fig. 12

Fig. 13



STEP 5

Attach Side Fascia

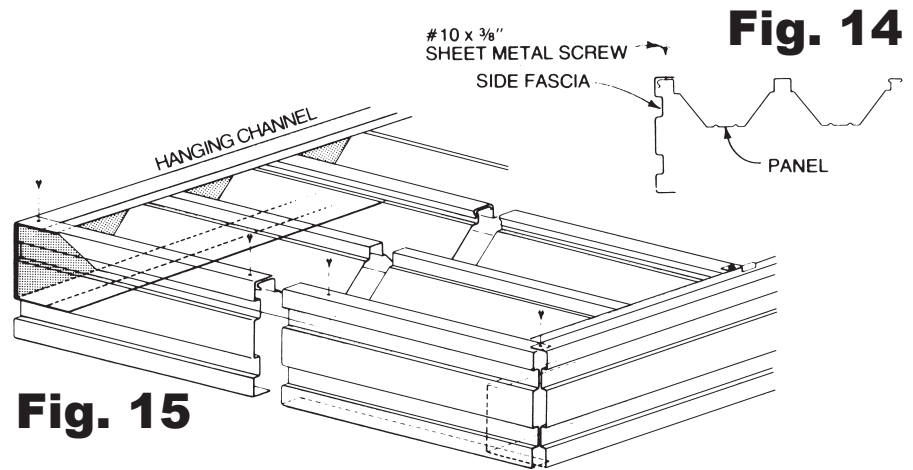

- Place the top flange of the side fascia (**Part 3**) over the top flange of the hanging channel (**Part 1**) at the wall. (**Fig. 14**)
- Place the top flange of the side fascia (**Part 3**) under the top flange of the front fascia (**Part 4**).
- Using adaptor and # 10 x 3/8" sheet metal screw (**Part 16**), fasten the side fascia (**Part 3**) to the hanging channel (**Part 1**) and front fascia (**Part 4**). Also fasten at approx. 24" spacing to panel. (**Fig. 15**).

STEP 6

Attach Fascia Clips and Corners

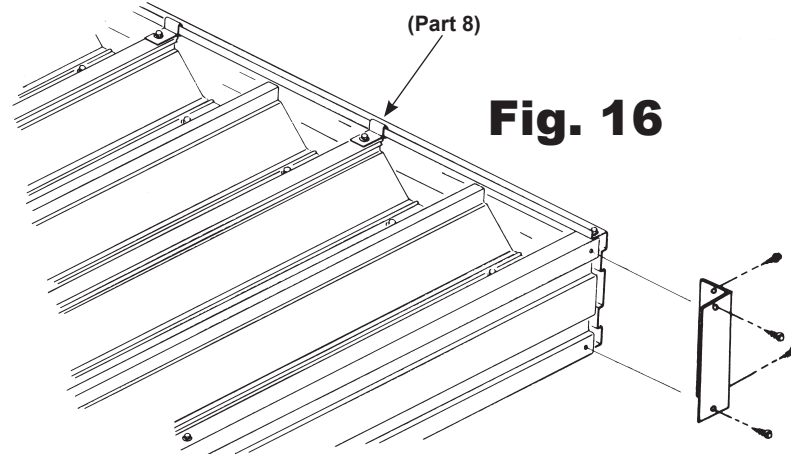

- Secure top of pans to front fascia with fascia clips (**Part 8**). Place top of clip over top leg in fascia where pans connect together and secure using #10 x 3/8" sheet metal screw (**Part 16**).
- Attach the corner angle (**Part 10**) to the front (**Part 4**) and side fascia (**Part 3**) using the socket drive and four #8 x 5/8" tek screws. (**Part 18A**)
- Fasten the corner angle (**Part 10**) to the side fascia (**Part 3**) only at wall location with two #8 x 5/8" tek screws. (**Part 18A**)

Patio Care and Maintenance

Your patio cover has a paint finish to resist the effects of damaging weather and aging. It is recommended you clean your patio cover at least twice a year by using a soft brush and mild detergent and wash off with water.