

# Semi Cutoff Wall Pack Series Installation Instructions



Models: 10137, 10138, 10139, 10140

**Important:** READ INSTRUCTIONS CAREFULLY BEFORE INSTALLING. KEEP THESE INSTRUCTIONS FOR FUTURE REFERENCE.

**WARNING** - Risk of fire or electric shock. To reduce the risk of electrical shock, fire, or injury to persons; read and follow all warnings and installation instructions before installing. All installation should be performed by a qualified electrician. Ensure power is off before installation or inspection. All wirings are performed in accordance with Electrical Code and local electrical code.

**WARNING** - Make certain power is switched OFF before starting installation or attempting any maintenance. Consult an electrician if not qualified to prevent electrical shock.

**WARNING** - Risk of Fire. Fixtures are rated for use in 120-277V, 50-60Hz protected circuit and 90 (rated supply wire)

**FOR YOUR SAFETY** - While performing installation described, gloves, safety glasses, or goggles should be worn.

Install this kit only in the luminaire that have the construction features and dimensions shown in the photographs and/or drawings.

Do not make or alter any open holes in an enclosure of wiring or electrical components during kit installation.

To prevent wiring damage or abrasion, do not expose wiring to edges of sheet metal or other sharp objects.

Do not alter, relocate, or remove wiring, lamp holders, power supply, or any other electrical component.

## SUITABLE FOR WET LOCATIONS

### Accessories

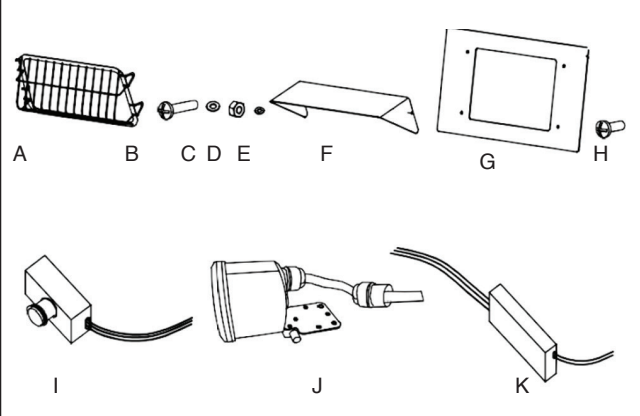

### Web-Guard Installation Parts List

Code	Name	Quantity
A	Web-guard	1
B	Stainless steel 304 cross machine screws #8-32*5/8	4
C	304 stainless steel flat	4
D	304 stainless steel nut	4
E	Nylon flat pad cp4	4

### Beauty Plate Installation Parts List

Code	Name	Quantity
G	Beauty plate	1
H	Stainless steel 304 cross machine screws #8-32*1/4	4

### Photocell installation parts list

Code	Name	Quantity
I	Photocell	1

### Visor installation parts list

Code	Name	Quantity
F	Visor	1
B	Stainless steel 304 cross machine screws #8-32*5/8	2
C	304 stainless steel flat	2
D	304 stainless steel nut	2
E	Nylon flat pad cp4	2

### Motion sensor installation parts list

Code	Name	Quantity
J	Motion sensor	1

### High voltage driver installation parts list

Code	Name	Quantity
K	High voltage drive 347-480V	1

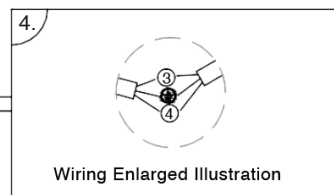
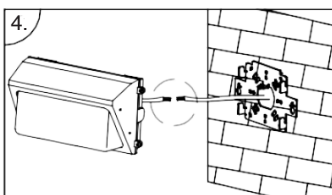
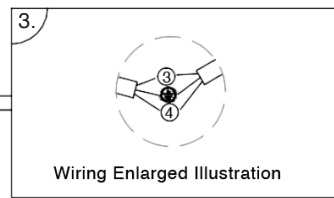
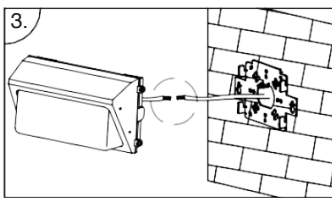
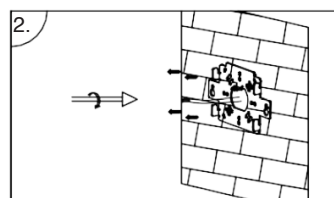
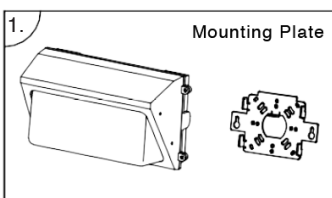

1. Open the box, remove the luminaire and remove the mounting panel.
2. Per the hole position of the installation panel, a hole is drilled on the installation surface, and then the fastener is fixed on the installation surface through the installation panel.
3. Wiring before luminaire installation, the zero line is connected to the zero line. The ground line is grounded, and the live line is connected to the fire line
4. According to Figure 4, mount the luminaire directly to the mounting panel.

### Wire Guard Installation Instructions

#### Open Frame

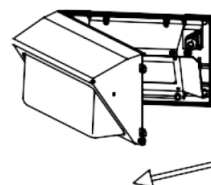

#### Frame

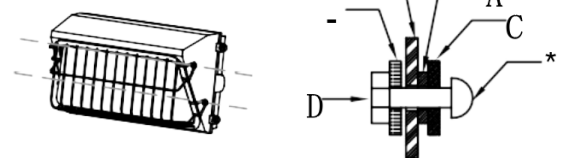

1. Install the wire guard based on below figure. Using the provided screws and nuts, secure the wire guard on each side of the luminaire

**Installation Instructions for Visor**

1. Install the Visor as shown in the figure, Screw acrosses flat washer  
 -Visor-Frame-Nylon flat washer-put nut on-fix Frame  
 Open Frame

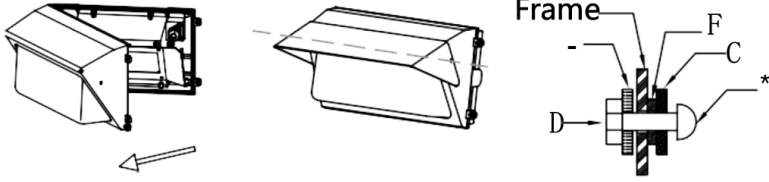

**Installation Instructions for Beauty Plate**

1. Install the Visor as shown in the figure, Screw acrosses flat washer  
 -Visor-Frame-Nylon flat washer-put nut on-fix Frame

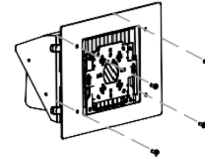

**Installation Instructions for 347-480V driver**

1. Install the Visor as shown in the figure, Screw acrosses flat washer  
 -Visor-Frame-Nylon flat washer-put nut on-fix Frame  
 Open Frame

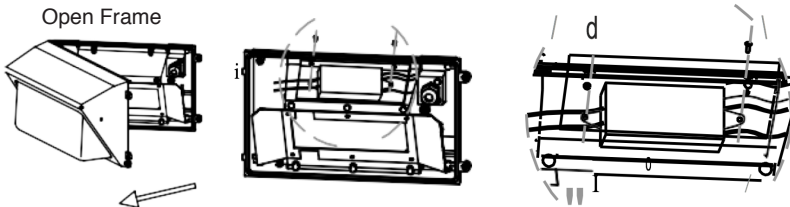

Fix the High voltage driver onto the gear plate

**Wiring diagram for High voltage driver**

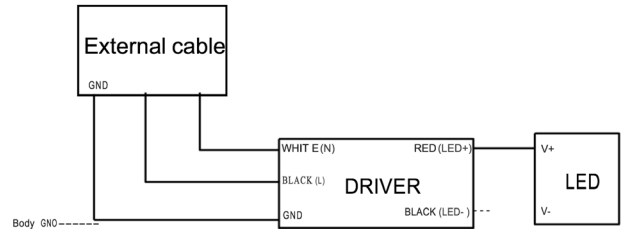

**Installation Instructions for Photocell**

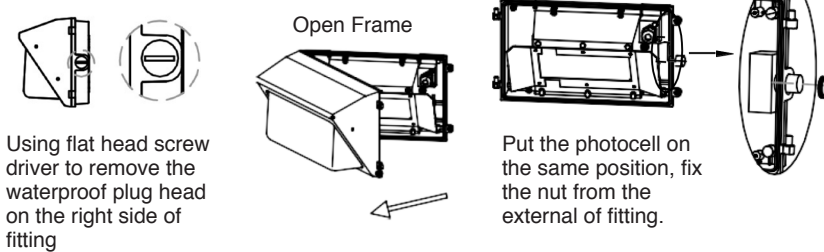

**Wiring diagram for Photocell**

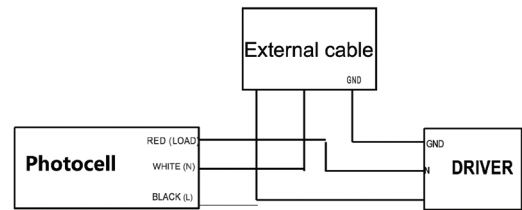

**Installation Instructions for Photocell**

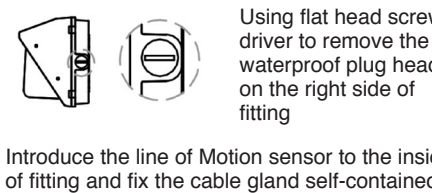

**Wiring diagram for Motion Sensor**

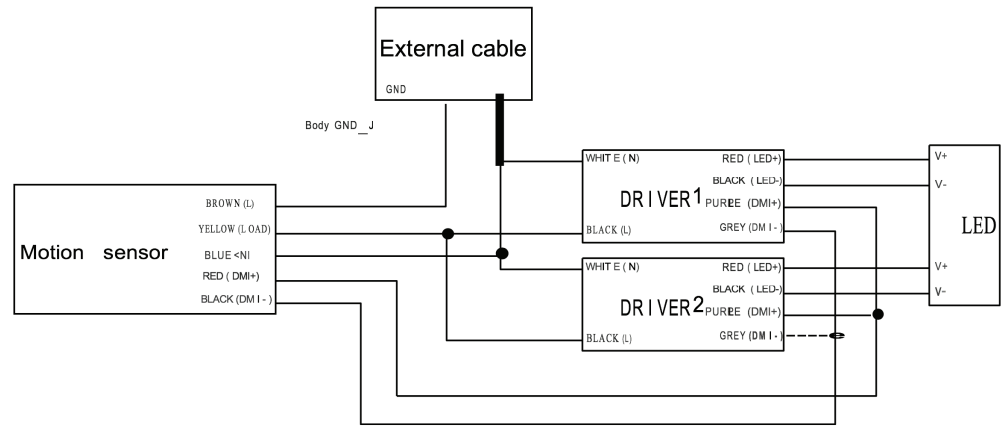
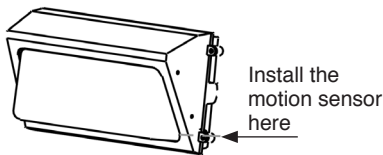

**Important Safety Information:**

- CAUTION: This luminaire must be wired in accordance with the National Electrical Code and applicable local codes and ordinances. Proper grounding is required to insure personal safety. Carefully observe grounding procedure under installation section.
- CAUTION: Installation and servicing of this equipment should be performed by qualified personnel only.
- CAUTION: Do not mount near gas or electrical heaters.
- CAUTION: Equipment should be mounted in locations and at heights where it will not readily be subjected to tampering by unauthorized personnel.
- CAUTION: The use of accessory equipment not recommended by the manufacturer may cause an unsafe condition. Any modification or use of non-original components will void the warranty and product liability.
- CAUTION: Do not use this equipment for other than intended use.
- CAUTION: Do not install in dead air, sheltered, buried or boxed in location. This luminaire should not be installed in areas that will entrap heat. It is not intended to be used in potentially dangerous or hazardous locations such as flammable or explosive atmospheres.
- CAUTION: This luminaire is not for use with UL924 Emergency Lighting Equipment.

**Warranty Information:**

This product is warranted for five years from the date of purchase. If this product does not perform to the specifications supplied on this package, send an email or write to the address below for product return and replacement. This replacement is the sole remedy available. Liability for incidental or consequential damage is expressly excluded. Visit [www.halcolighting.com](http://www.halcolighting.com) for full warranty details and compatibility information.