

Setup

Start

Before you begin:

DO NOT FILL THE STEAMER WITH ANY LIQUIDS EXCEPT CLEAN WATER. Do not use household cleaners, bleach or any other chemicals with this steamer.

Never use more than two extensions when using the steamer.

Never attach extensions or accessories while unit is emitting steam.

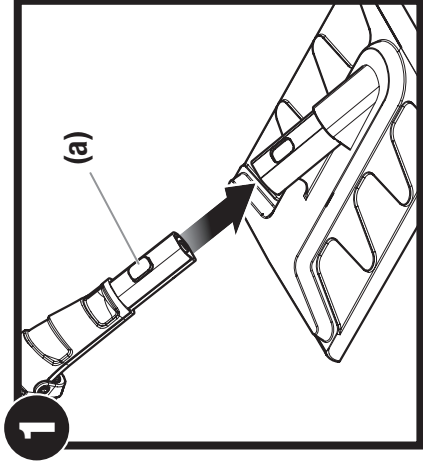

1. Push the button on the handle (a) and attach the steam plate, extensions, or cleaning accessory to the trigger mechanism.

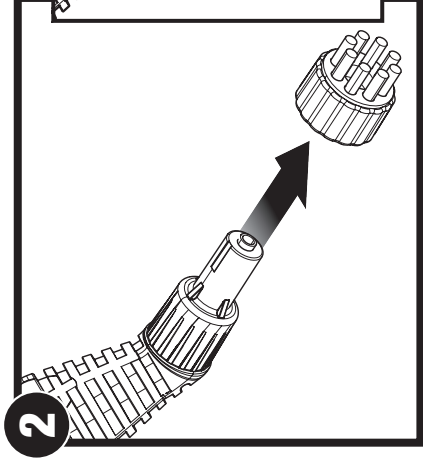

2. If using the jet nozzle, assemble the brush onto the nozzle.

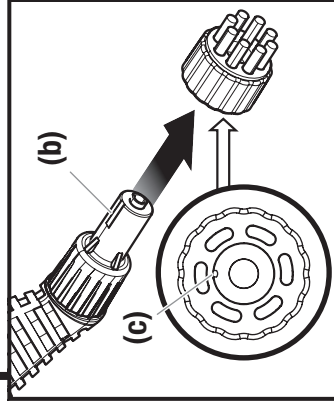

Note: When attaching the nozzle brush to the jet nozzle, line up the notch in the jet nozzle end (b) with the guide inside the nozzle brush (c).

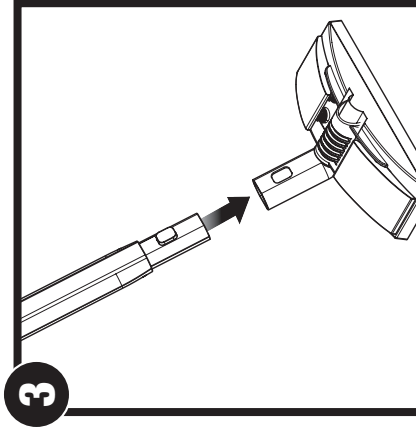

3. If using an extension, attach the accessory to the extension.

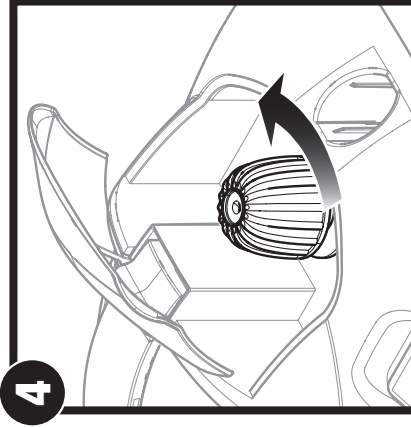

4. Flip up filler cap lid and carefully unscrew filler cap.
Using the funnel, fill the steamer with clean tap water (distilled water recommended). **DO NOT OVERFILL.**

Amount of water	Steam time
16 oz.	15 min
32 oz.	30 min
48 oz.	45 min

5. Use the chart above as a guide to determine how much water you will need based on how long you need to use the steamer.
Replace fill cap and shut filler cap lid when filled with desired amount.

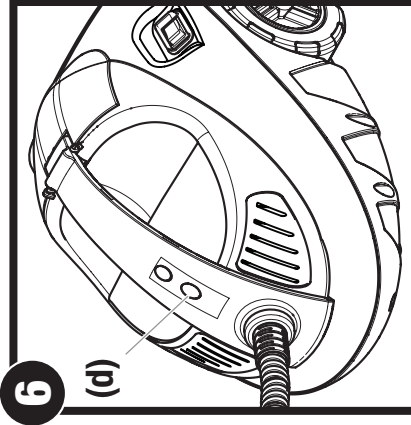

6. Plug in the power cord and turn the switch ON (I). Both the green and red indicator lights will turn on.
Once the red indicator light on the container turns off (d), you are ready to begin steaming.

Note: When the red light turns back on, you can continue steaming.