

Item #739 254



Model #HD17555

USE AND CARE GUIDE

Plaza Mayor Bistro Table



Questions, problems, missing parts? Before returning to the store,
call Hampton Bay Customer Service
8:00 a.m. - 7:00 p.m., EST, Monday-Friday
9:00 a.m. - 6:00 p.m., EST, Saturday

1-855-HD-HAMPTON

HAMPTONBAY.COM

THANK YOU

We appreciate the trust and confidence you have placed in Hampton Bay through the purchase of this table. We strive to continually create quality products designed to enhance your home. Visit us online to see our full line of products available for your home improvement needs. Thank you for choosing Hampton Bay!

Table of Contents

Table of Contents.....	2	Pre-Assembly.....	3-4
Safety Information.....	2	Planning Assembly.....	3
Warranty.....	2	Hardware Included.....	3
2 Year Frame Limited Warranty.....	2	Package Contents.....	4
1 Year Wood Component Limited Warranty.....	2	Assembly	5-6
What Is Covered?.....	2		
What Is Not Covered?.....	2		
Care Instructions.....	2		

Safety Information

 **DANGER:** Keep children out of the assembly area before assembly.

 **WARNING:** Do not sit or stand on the table.

 **WARNING:** Do not put heavy objects on the table.

 **IMPORTANT:** Maintain the wood component with teak or linseed oil at least once every 30 days.

 **CAUTION:** Use the table on flat ground only.

 **IMPORTANT:** Check the tightness of all bolts at least once every 90 days.

 **NOTE:** Level the table with glides at the bottom of each leg.

Warranty

2 YEAR FRAME AND 1 YEAR WOOD COMPONENT LIMITED WARRANTY

WHAT IS COVERED

We warrant the frame to be free of manufacturing defects to the original purchaser for two years and wood component for one year.

WHAT IS NOT COVERED

It remains the customer's responsibility for freight and packaging charges to and from our service center. This warranty does not cover commercial use, hardware, acts of nature, fire, freezing and abusive use. In addition, purchased parts are not covered under this warranty. We reserve the right to make substitutions with similar merchandise, if the model in question is no longer in production.

Care Instructions

Before using, wipe with a clean, dry cloth. Do not use bleach or solvents. Treat the frame with liquid wax for maximum protection against UV light and salty, damp air. When not in use, store furniture in a cool, dry place. If the set includes cushions or mesh fabric, they may be cleaned by hand with a mild solution of soap and water. Rinse cushions thoroughly and allow to drip dry. Do not machine wash or tumble dry, as cushions may shrink. Do not use bleach or solvents on fabrics. When cleaning the tabletop make sure to use a soft clean cloth that does not bleed color.

ADDITIONAL CARE INSTRUCTIONS FOR WOOD

Your patio furniture set contains natural, eucalyptus wood. If untreated, it will weather to a majestic, soft gray. However, it can be stained to maintain its rich tones. To maintain the new appearance, it is recommended to apply teak or linseed oil before you use, and occasionally throughout the season. For ideal care of your wood furniture, we recommend the following tips:

For daily care, wipe with a soft, dry cloth. Avoid the use of harsh cleaners and abrasives. Wipe spills immediately with a clean dry cloth. If there is a food stain or animal droppings wipe clean with a soft cloth and some warm water. Cover furniture with outdoor covers when left outside during inclement weather or when not in use. Please be sure you use a proper cover that allows for adequate ventilation without trapping moisture. In the off-season, store indoors.

You may contact our customer service department with any questions by phone at 1-855-HD-HAMPTON or visit www.hamptonbay.com.

Pre-Assembly

PLANNING ASSEMBLY

Assemble this product on a blanket, towel or other soft, non-abrasive surface to avoid scratching the finish.

HARDWARE INCLUDED



NOTE: Hardware not shown to actual size.

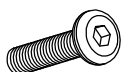

___AA



___BB



___CC



___DD

Part	Description	Quantity
AA	Bolt (M6 x 20mm)	16
BB	Metal Washer (M6)	16
CC	Allen Wrench (M6)	1
DD	Plastic Bolt Cap (M6)	16

Pre-Assembly (continued)

PACKAGE CONTENTS

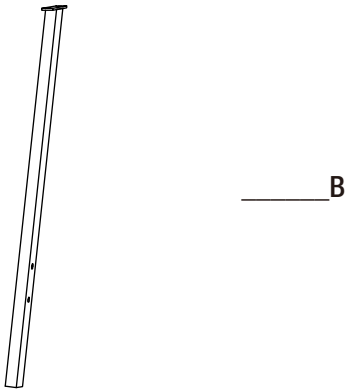
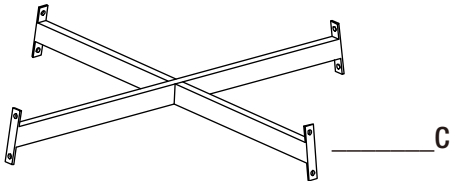
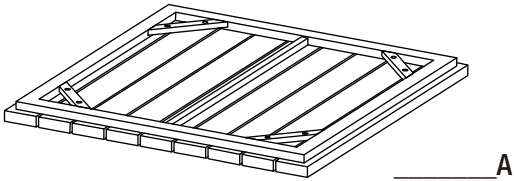

Part	Description	Quantity
A	Table Top	1
B	Table Leg	4
C	Leg Connector Bracket	1

Assembly

1 Attaching the table legs to the table top

- Place the table top (A) upside down on a blanket, towel, or other soft surface so the pre-drilled corner holes are visible.
- Attach the four table legs (B) to the table top (A) by inserting the bolts (AA) with metal washers (BB) through the pre-drilled holes.



IMPORTANT: Do not tighten completely until assembly is completed.

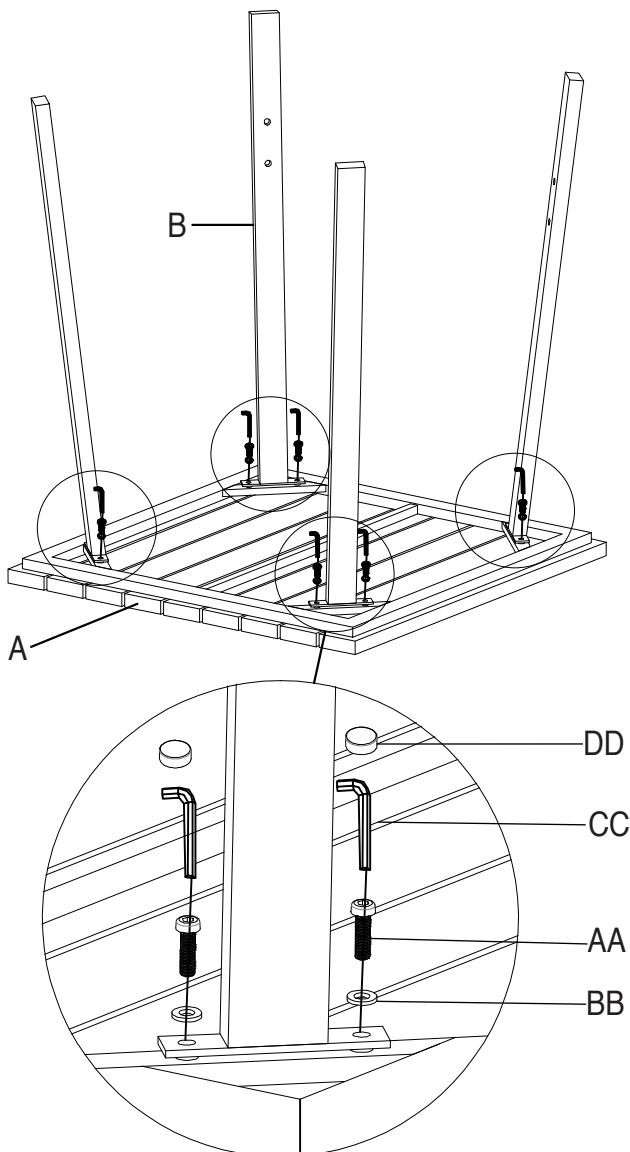

2 Assembling the leg connector bracket to the legs

- Attach the leg connector bracket (C) to the four legs (B) by inserting bolts (AA) with metal washers (BB) through the holes on the inside of the legs.



IMPORTANT: Do not tighten completely until assembly is completed.

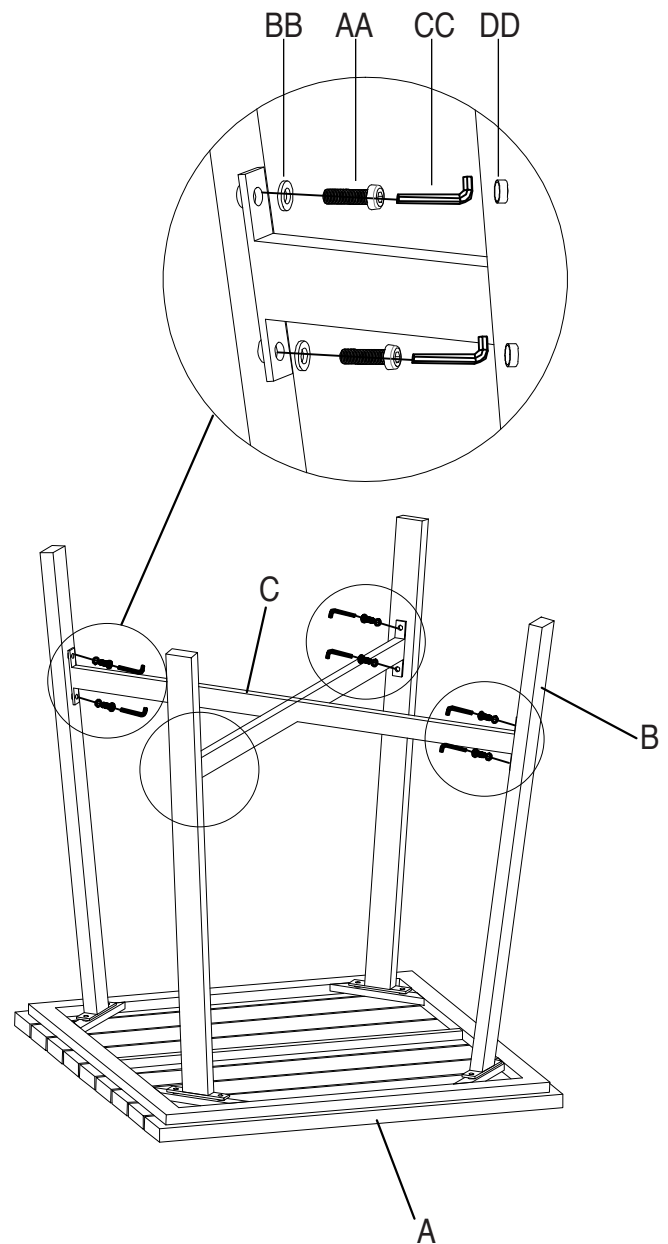

3 Completing the assembly

- Tighten all the bolts using the wrench (CC) and cover them with the plastic bolt caps (DD).
- Turn the table in the upright position. Your table is now ready for use, so relax & enjoy!

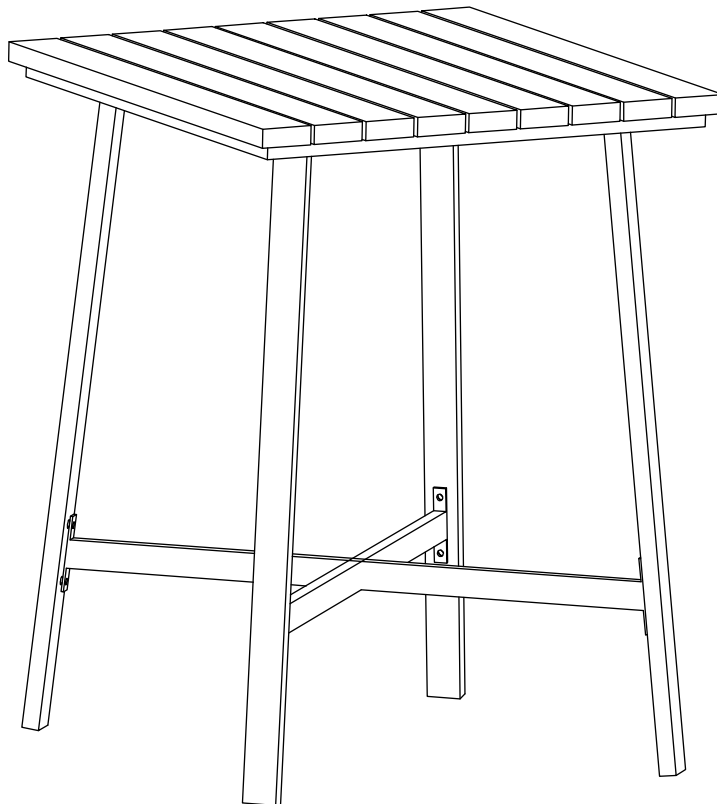

IMPORTANT: Your patio furniture set contains natural, eucalyptus wood. If untreated, it will weather to a majestic, soft gray. However, it can be stained to maintain its rich tones. To maintain the new appearance, it is recommended to apply teak or linseed oil before you use, and occasionally throughout the season.

For ideal care of your wood furniture, we recommend the following tips: For daily care, wipe with a soft, dry cloth. Avoid the use of harsh cleaners and abrasives. Wipe spills immediately with a clean dry cloth. If there is a food stain or animal droppings wipe clean with a soft cloth and some warm water. Cover furniture with outdoor covers when left outside during inclement weather or when not in use. Please be sure you use a proper cover that allows for adequate ventilation without trapping moisture. In the off-season, store indoors.



Questions, problems, missing parts? Before returning to the store,
call Hampton Bay Customer Service
8:00 a.m. - 7:00 p.m., EST, Monday-Friday
9:00 a.m. - 6:00 p.m., EST, Saturday

1-855-HD-HAMPTON

HAMPTONBAY.COM

Retain this manual for future use.