

1548013COM FRANKLIN SPACE SAVER

Ameriwood
HOME

Date of Purchase: ____/____/____
Lot Number:

B341548013COM00

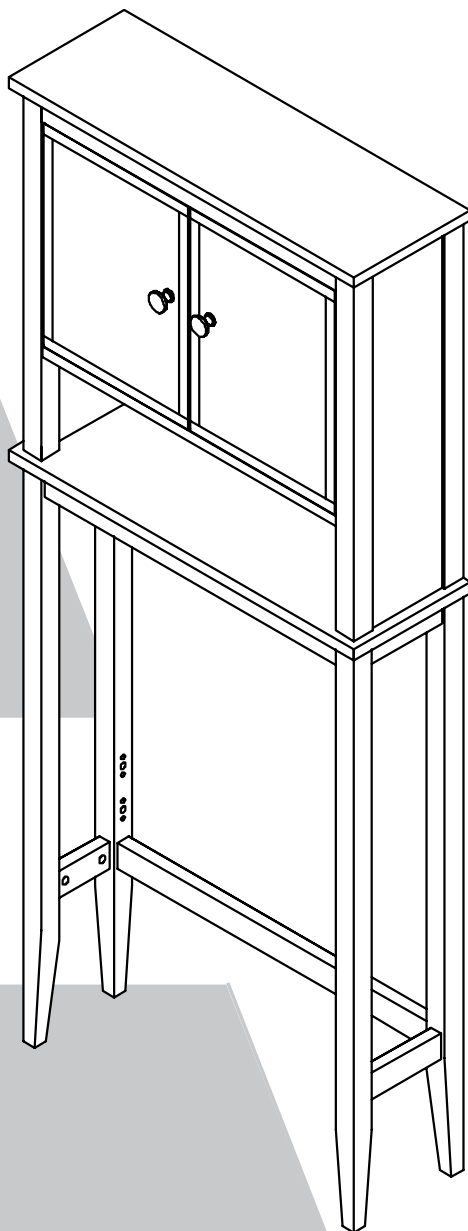

THIS INSTRUCTION BOOKLET CONTAINS **IMPORTANT** SAFETY INFORMATION. PLEASE READ AND KEEP FOR FUTURE REFERENCE.

Do Not Return This Product!

Contact our customer service team for help first
Call: 1-800-489-3351 (toll free)
Monday-Friday 9am - 5pm CST
Visit: www.ameriwoodhome.com



WARNING

- Unit can tip over causing severe injury or death.
- Anchor unit to stud in wall (if instructed to)
- Do not allow children climb on unit
- Put heavy items on lower shelves or drawers

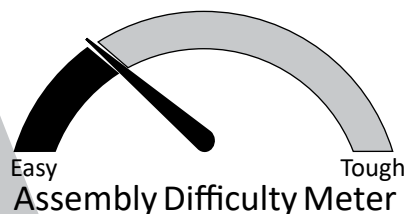

Follow Ameriwood Home



Contact Us!

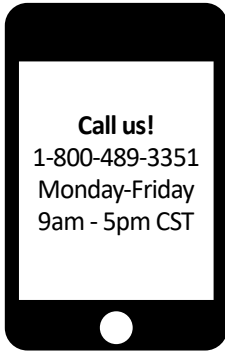

Do NOT return this product!
Contact our friendly customer service team first for help

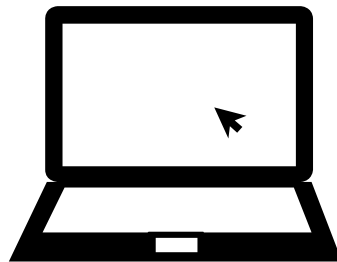

Visit ameriwoodhome.com

Assembly Tips



Helpful Hints

PEOPLE NEEDED FOR ASSEMBLY: **1-2**
ESTIMATED ASSEMBLY TIME: **1 HOUR**

- Open your item in the area you plan to keep it for less heavy lifting
- Identify, sort and count the parts before attempting assembly
- Compression dowels are tapped in with a hammer
- Slides are labeled with a R (right) and L (left) for proper placement
- Make sure to always face the point on the top of the Cam Lock towards the outer edge
- Use all the nails provided for the back panel and spread them out equally
- Back Panel must be used to make sure your unit is sturdy
- Do NOT use harsh chemicals or abrasive cleaners on this item
- Never push, pull, or drag your furniture



Before You Start

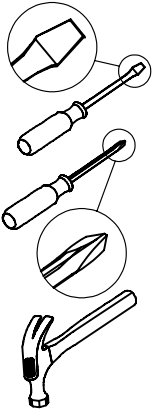
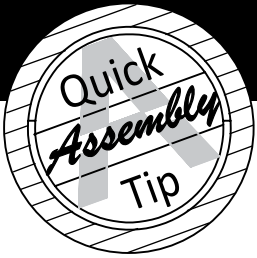

- ✓ Read through each step carefully and follow the proper order
- ✓ Separate and count all your parts and hardware
- ✓ Give yourself enough room for the assembly process
- ✓ Have the following tools: Flat Head Screwdriver, #2 Phillips Head Screwdriver and Hammer
- ✓ Caution: If using a power drill or power screwdriver for screwing, please be aware to slow down and stop when screw is tight. Failure to do so may result in stripping the screw.

Cam Lock Fastening System

This Cam Lock Fastening System will be used throughout the assembly process.

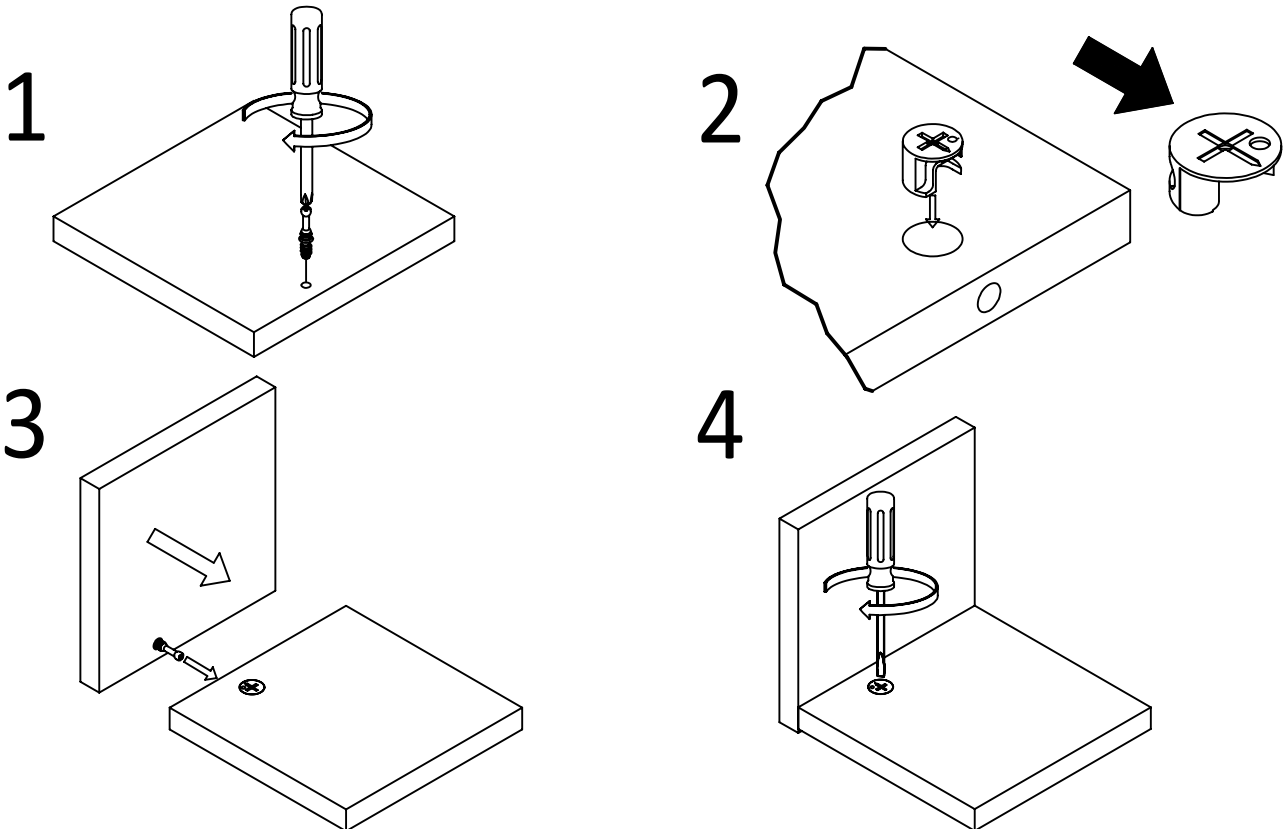

Board Identification

Not actual size

1

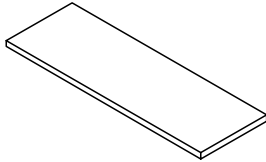

x1
T1548013010
TOP PANEL

2

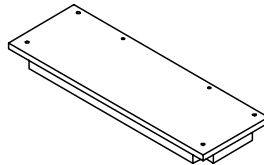

x1
T1548013020
BOTTOM PANEL

3

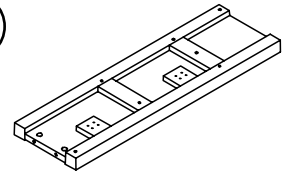

x1
T1548013030
LEFT SIDE PANEL

4

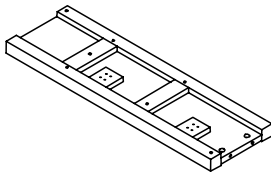

x1
T1548013040
RIGHT SIDE PANEL

5

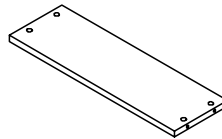

x1
T1548013050
CENTER FIXED SHELF

6

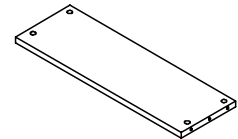

x1
T1548013060
FIXED SHELF

7

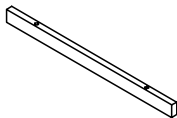

x2
T1548013070
RAIL

8

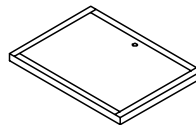

x2
T1548013080
DOOR

9

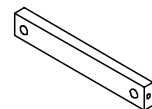

x2
T1548013090
LOWER SIDE RAIL

Board Identification

Not actual size

10

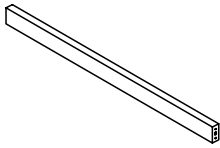

x1
T1548013100
LOWER SUPPORT RAIL

11



x1
T1548013110
FRONT LEFT LEG

12

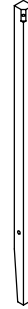

x1
T1548013120
FRONT RIGHT LEG

13



x1
T1548013130
BACK LEFT LEG

14

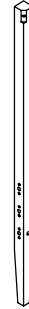

x1
T1548013140
BACK RIGHT LEG

15

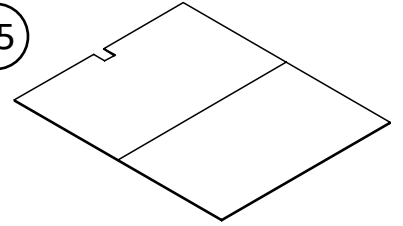

x1
T1548013150
BACK PANEL

Part List

Actual Size



x16
TUD0001
Cam Bolt

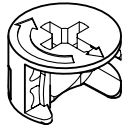

x16
TUD0002
Cam Lock
15-12

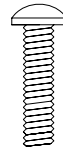

x2
TUD0057
PH M4 X 16

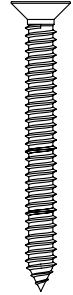

x4
TUD0009
CBS 4 x 38



x4
TUD0058
CBS 4 x 45



x24
TUD0008
CBS 3.5 x 16



x4
TUD0004
DOWEL M8 X 25

Part List

Not Actual Size

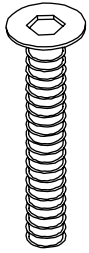

x4
TUD0059
JCBC Screw
M6 X 65

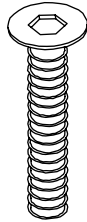

x4
TUD0052
JCBC Screw
M6 X 30

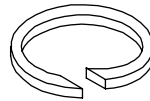

x8
TUD0041
SPRING WASHER

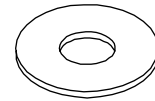

x4
TUD0042
FLAT WASHER

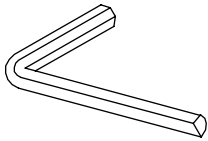

x1
TUD0026
ALLEN KEY
M4

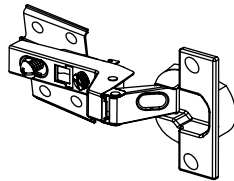

x4
TUD0037
HINGE Ø35



x2
TUD0056
SMALL SILVER KNOB

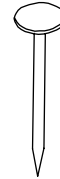

x14
TUD0006
NAIL

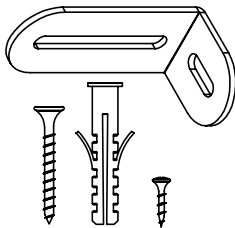

x1 SET
TUD0021
ANTI TIPPING KIT



x2
TUD0061
RUBBER PAD

* raw edges are shaded

Step 1

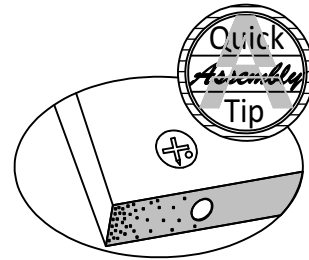
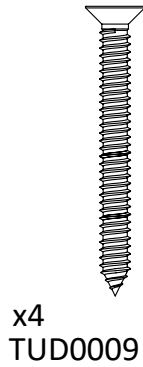
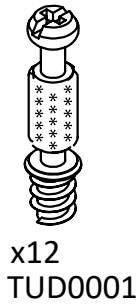
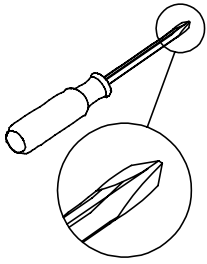

Proper orientation of CAM LOCK

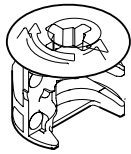
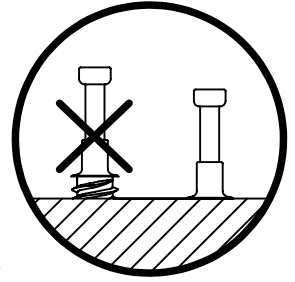

x16
TUD0002

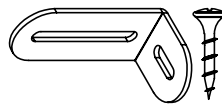

x1
TUD0021

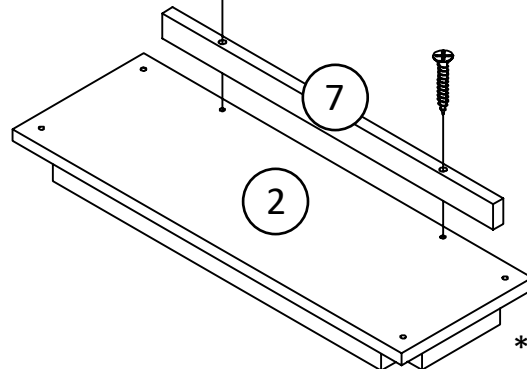
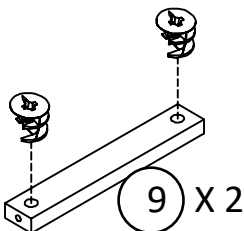
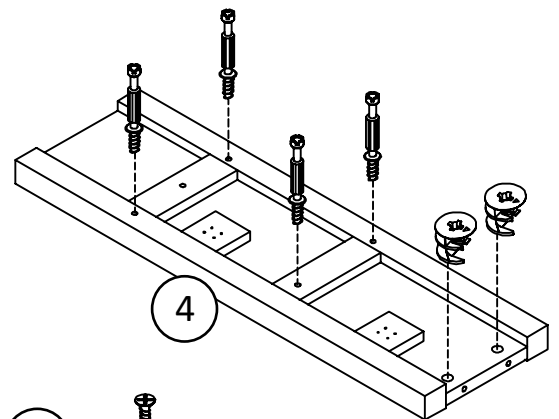
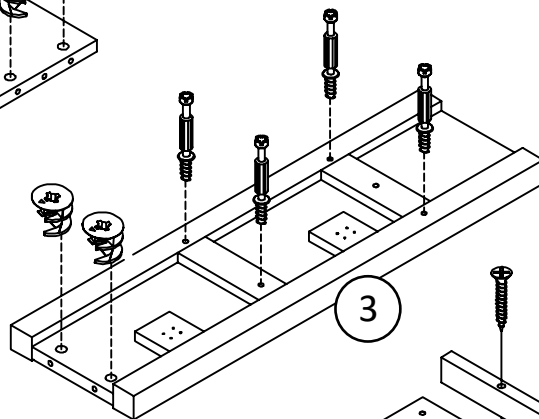
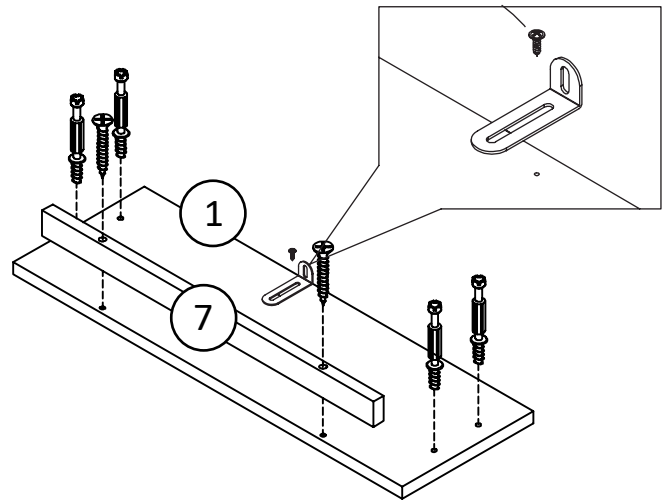
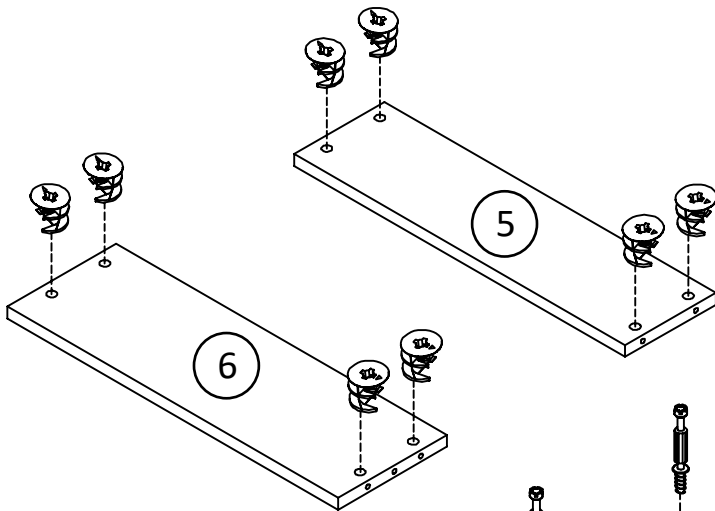
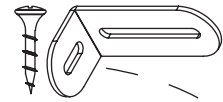

* raw edges are shaded

Step 2

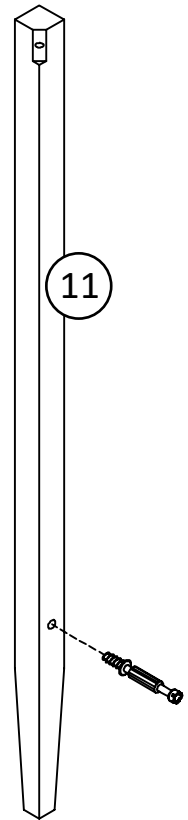
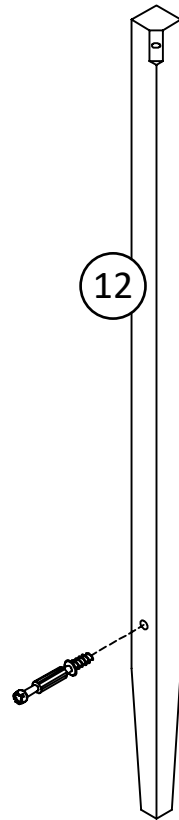
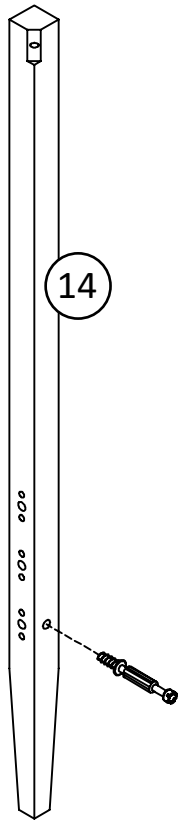
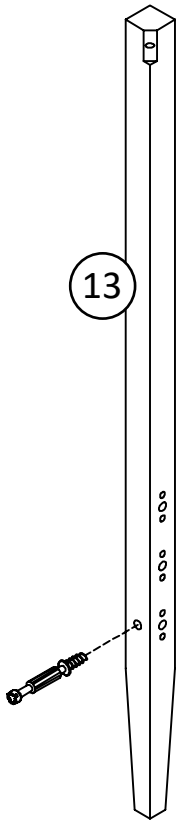
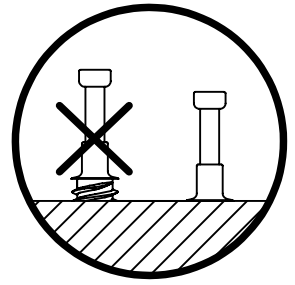
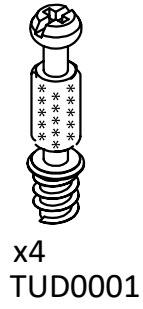
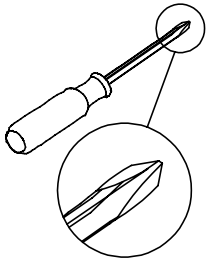

* raw edges are shaded

Step 3

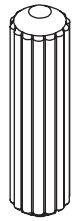
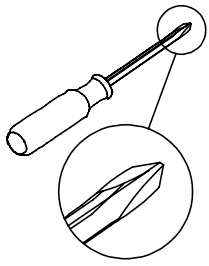

x2
TUD0004

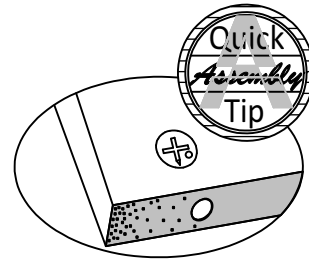
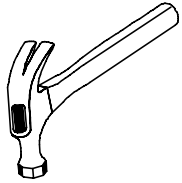

Proper orientation of CAM LOCK

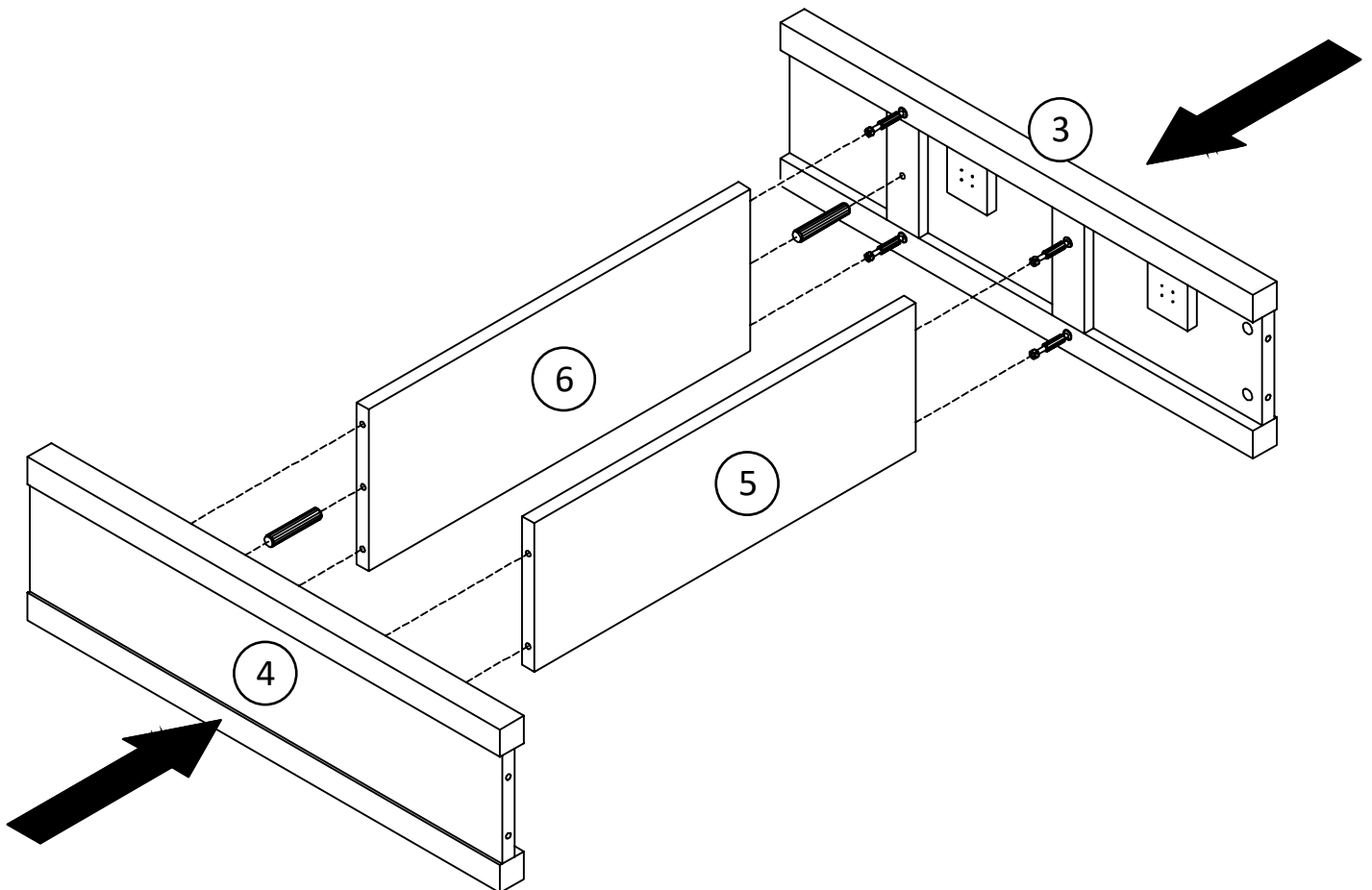
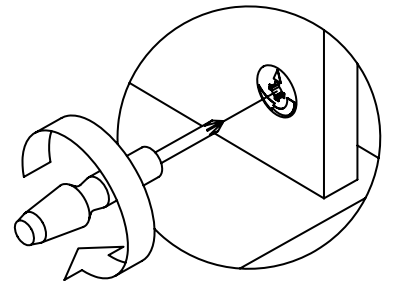
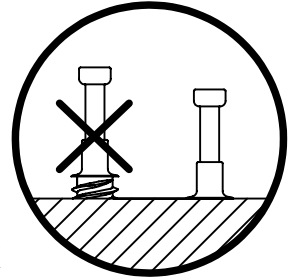

* raw edges are shaded

Step 4

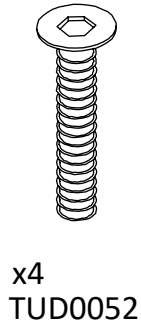
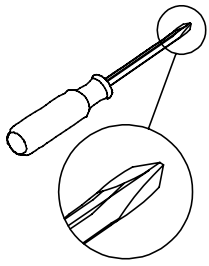

x4
TUD0052

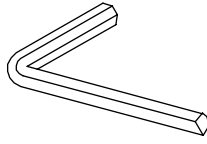

x1
TUD0026

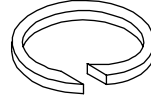

x4
TUD0041

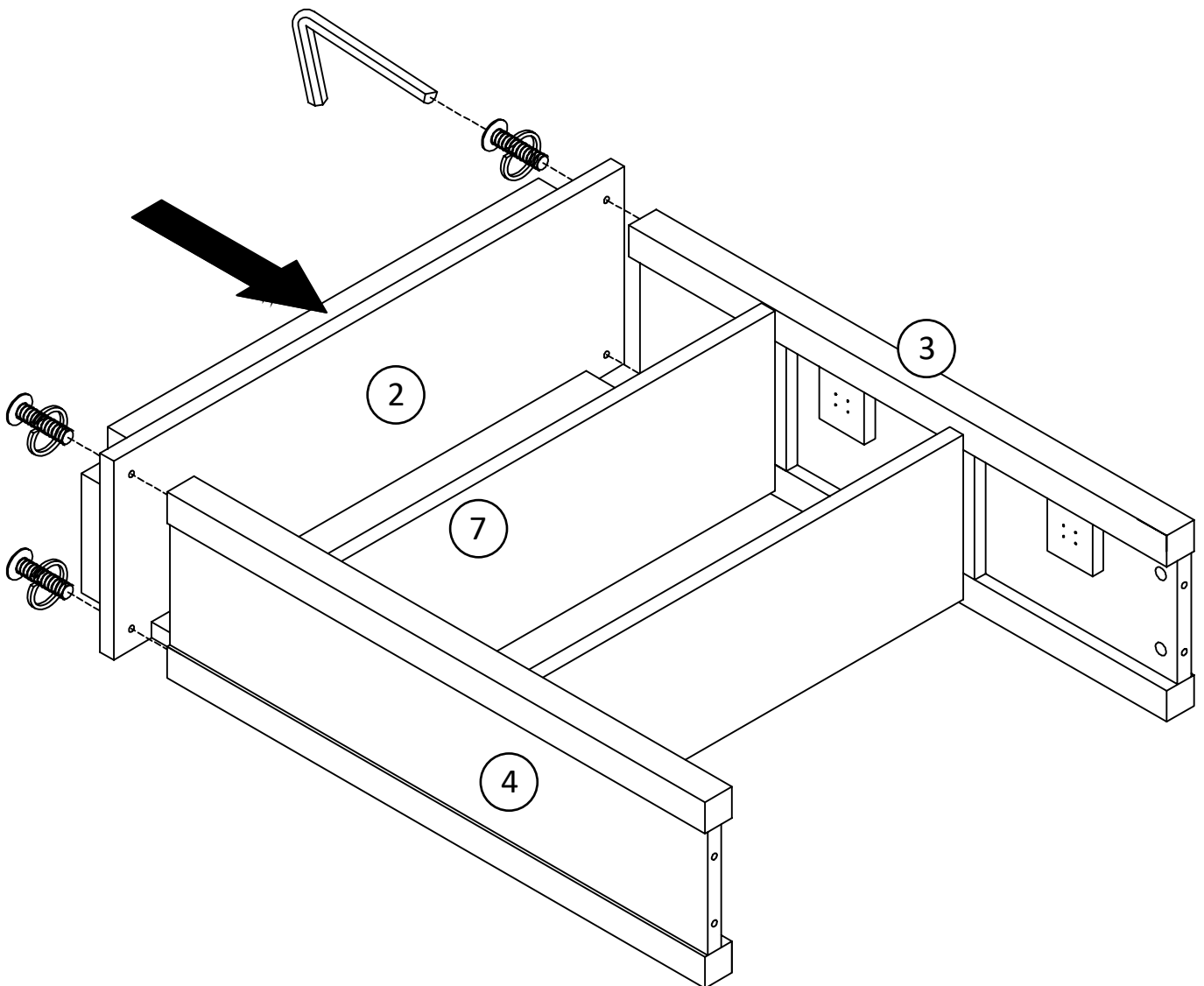

* raw edges are shaded

Step 5

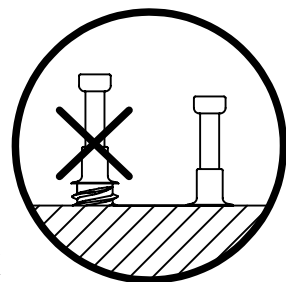
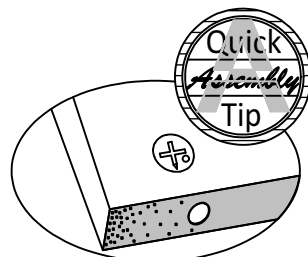
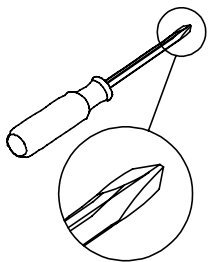

Proper orientation of CAM LOCK

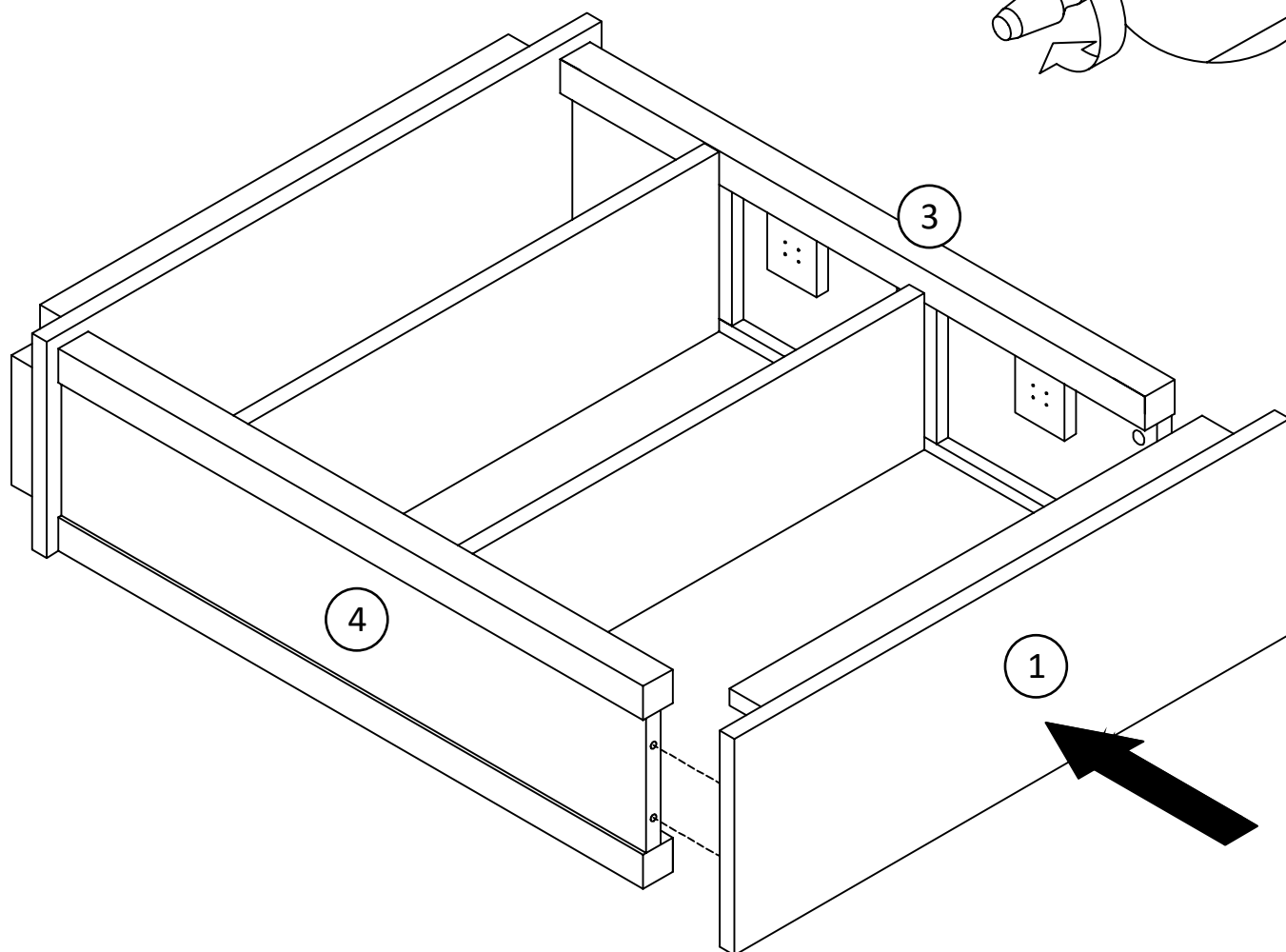
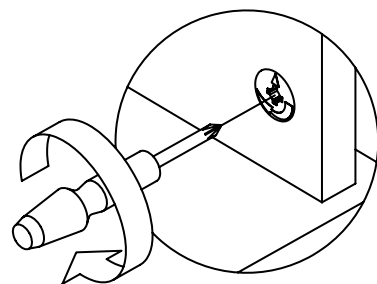

* raw edges are shaded

Step 6

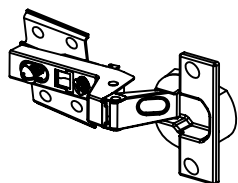
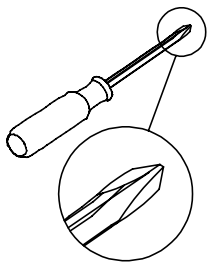

x4
TUD0037
HINGE Ø35



x8
TUD0008
CBS 3.5 x 16

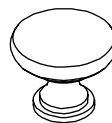

x2
TUD0056
HANDLE

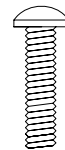

x2
TUD0057
PH M4 X 16

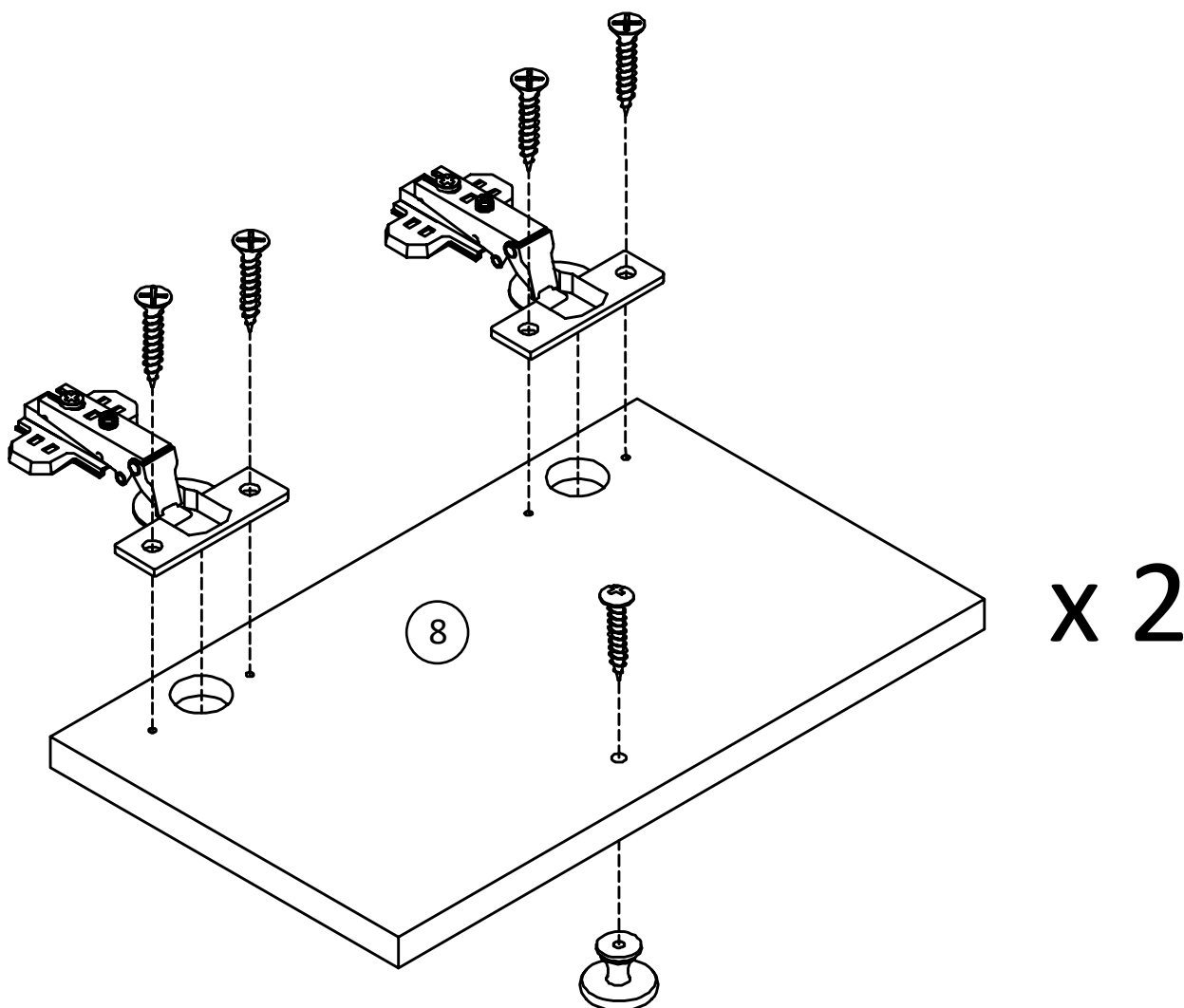

* raw edges are shaded

Step 7

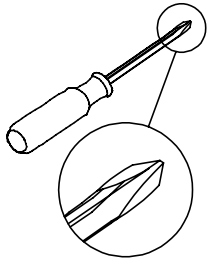

x16
TUD0008
CBS 3.5 x 16



x2
TUD0061

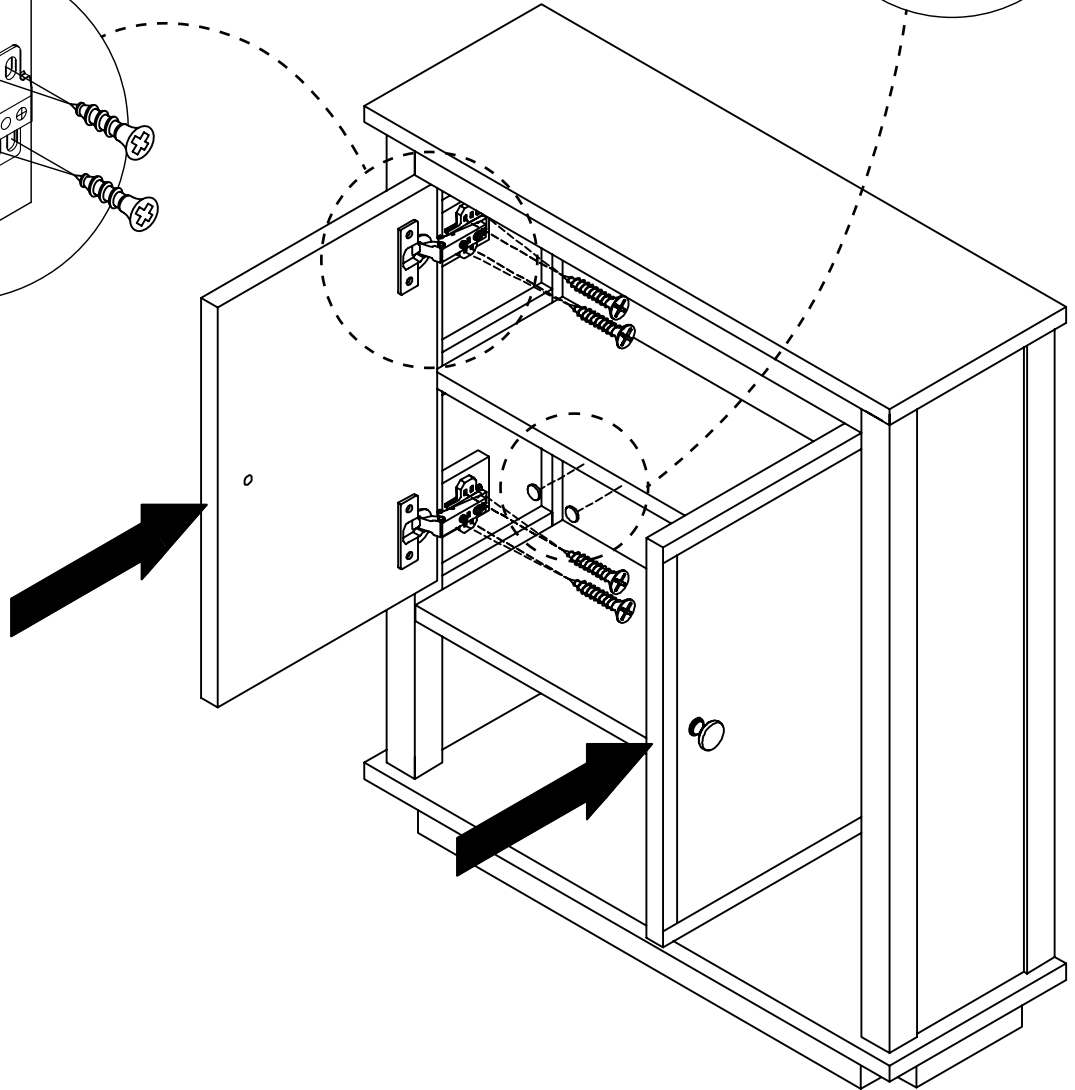
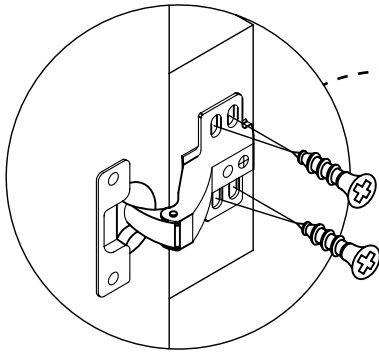
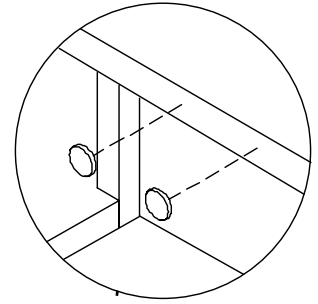

* raw edges are shaded

Step 8

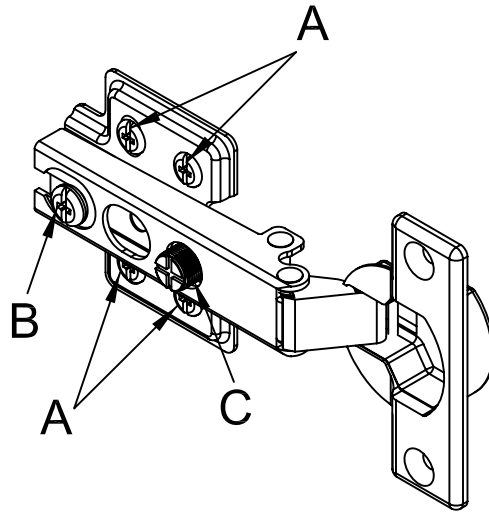

<p>Cabinet</p> <p>Door</p>	<p>To adjust the vertical height. Loosen the four screws "A" on both hinges. Two of them are usually in slotted holes which allows you to adjust up or down by a few mm. Then tighten back up.</p>
<p>Cabinet</p> <p>Door</p>	<p>To adjust depth. Loosen screw "B" and adjust door, if the door can not be adjusted, please loosen screw "C", then try again. Tighten screw "B" and "C".</p>
<p>Cabinet</p> <p>Door</p>	<p>To adjust side ways. Turning the screw "C" on BOTH hinges on each door.</p>

* raw edges are shaded

Step 10

Option 1

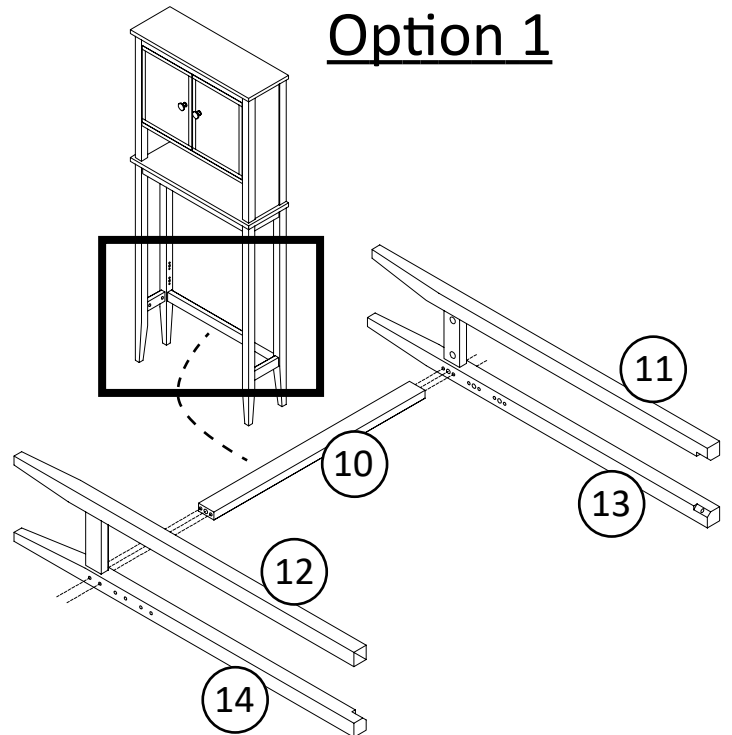

Option 2

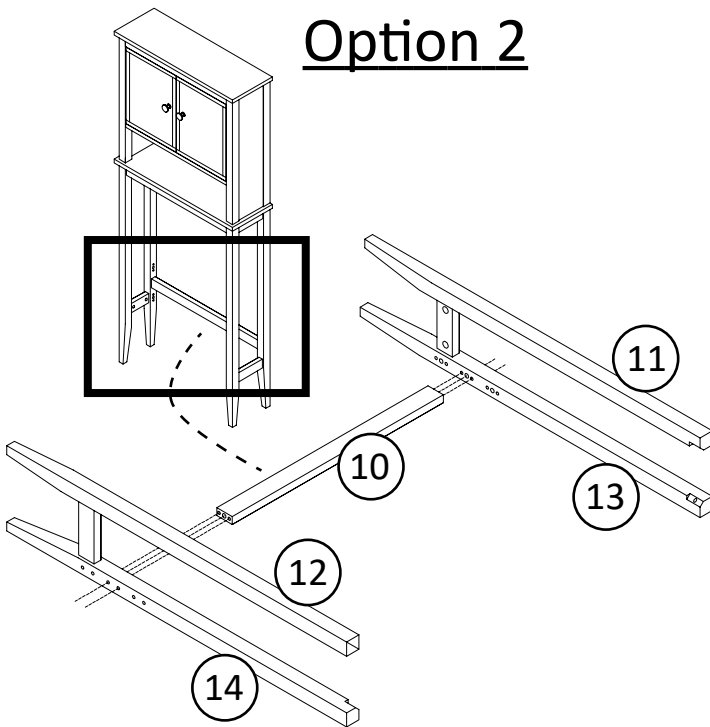

Option 3

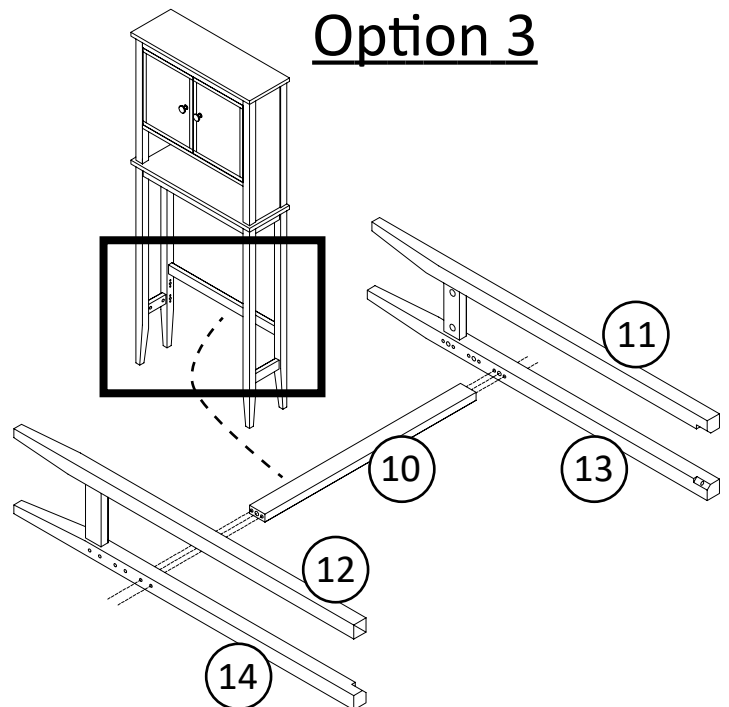

* raw edges are shaded

Step 11

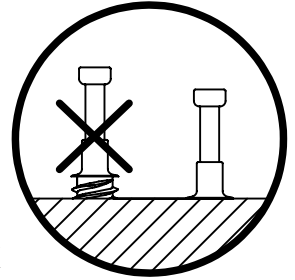
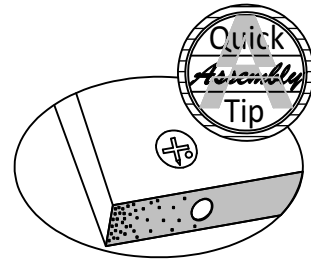
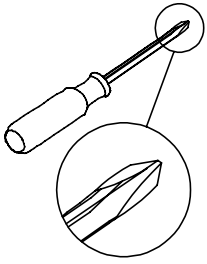

Proper orientation of CAM LOCK

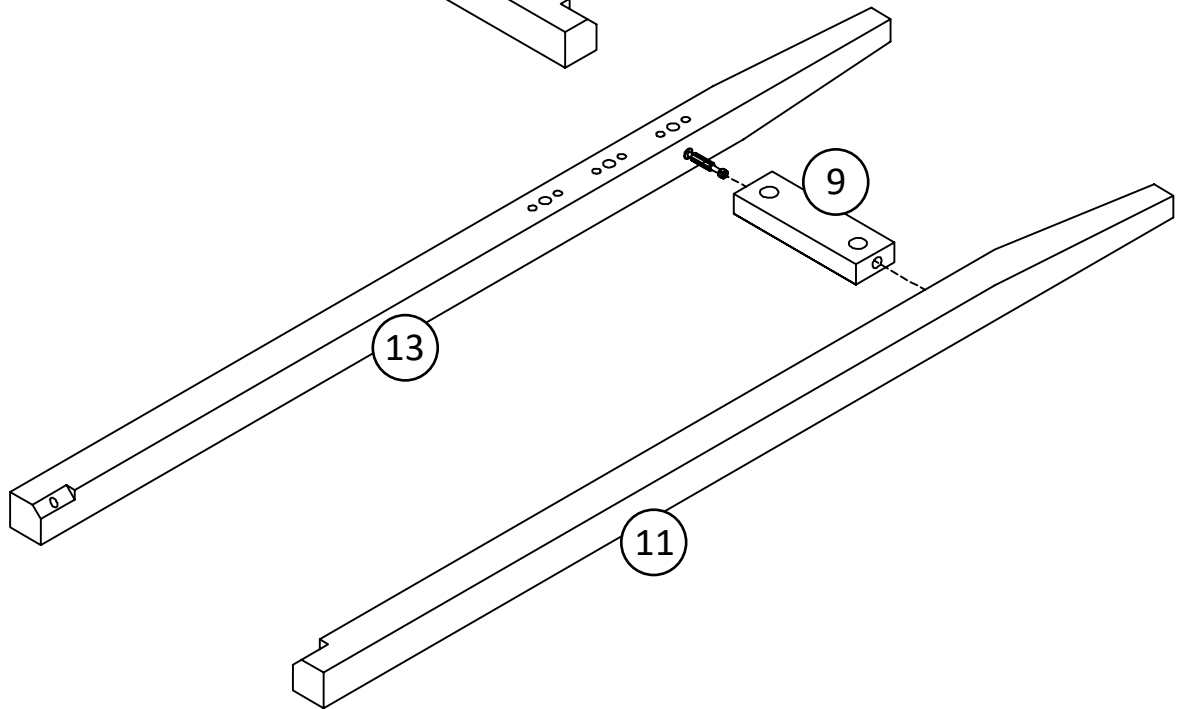
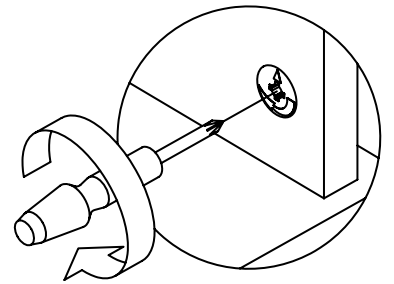
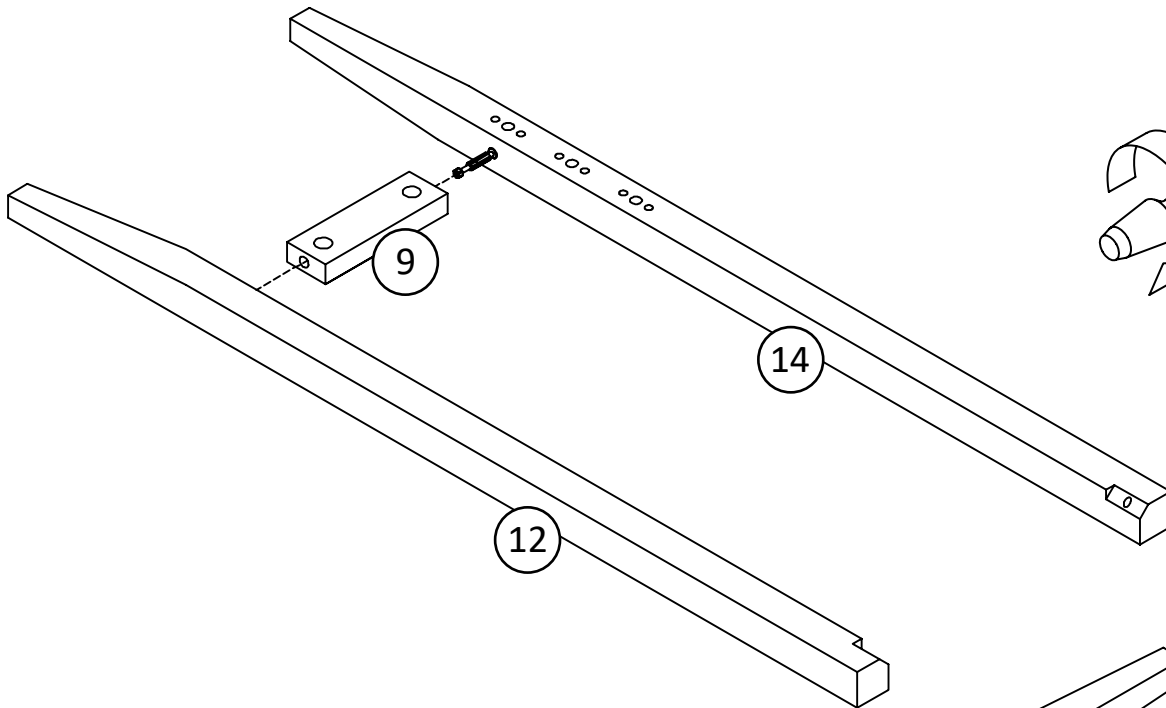

* raw edges are shaded

Step 11



x2
TUD0043

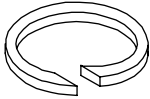

x2
TUD0041

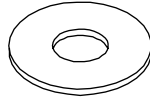

x2
TUD0042

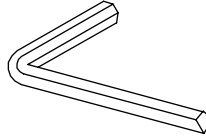

x1
TUD0026

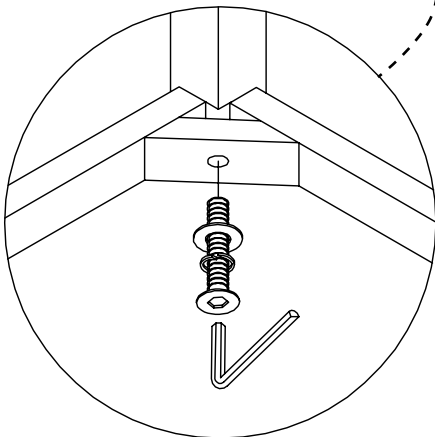
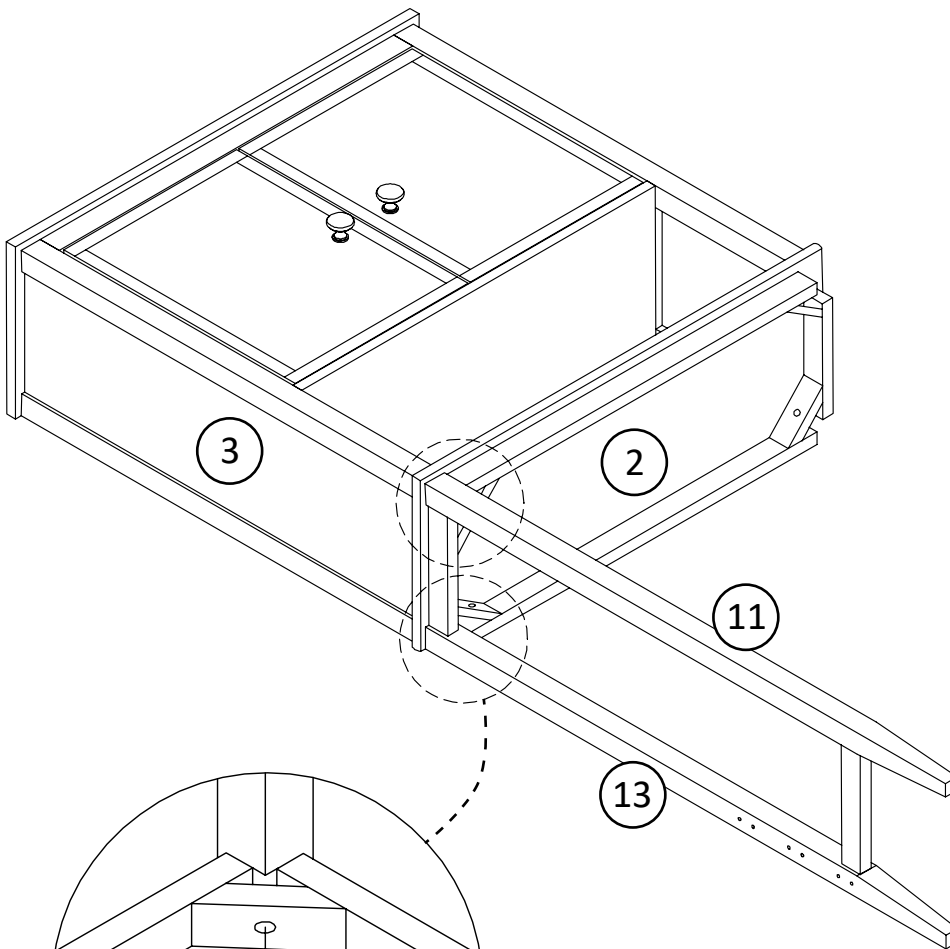

* raw edges are shaded

Step 12

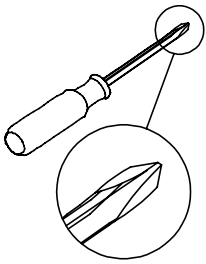

x2
TUD0004



x2
TUD0058

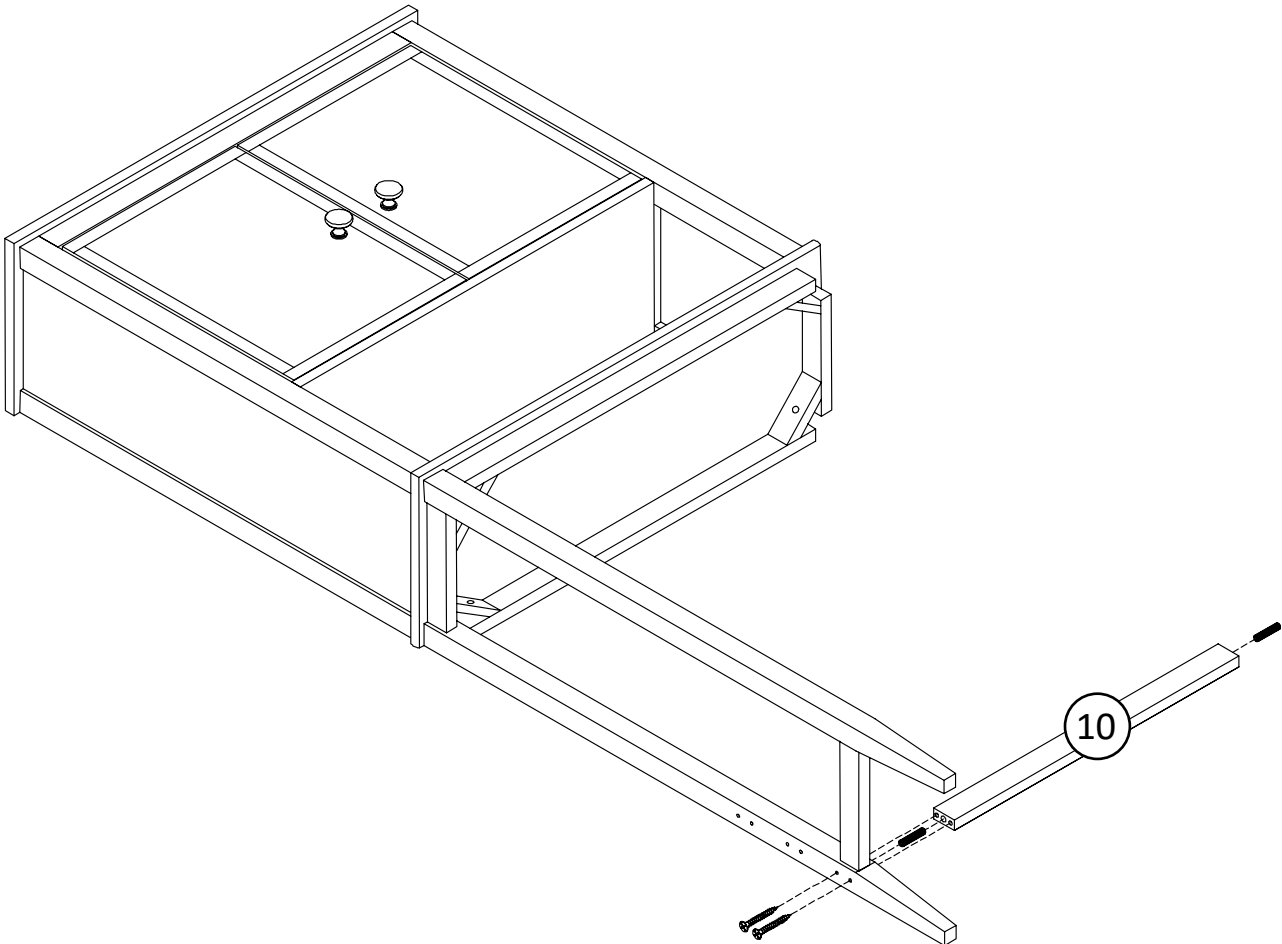
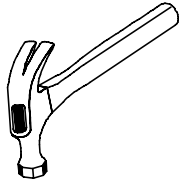

* raw edges are shaded

Step 13

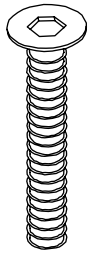
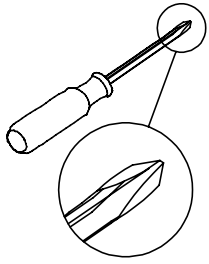

x2
TUD0043

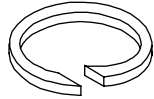

x2
TUD0041

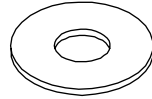

x2
TUD0042

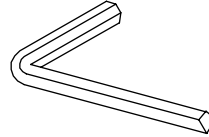

x1
TUD0026

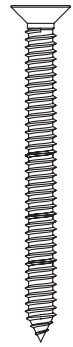

x2
TUD0058

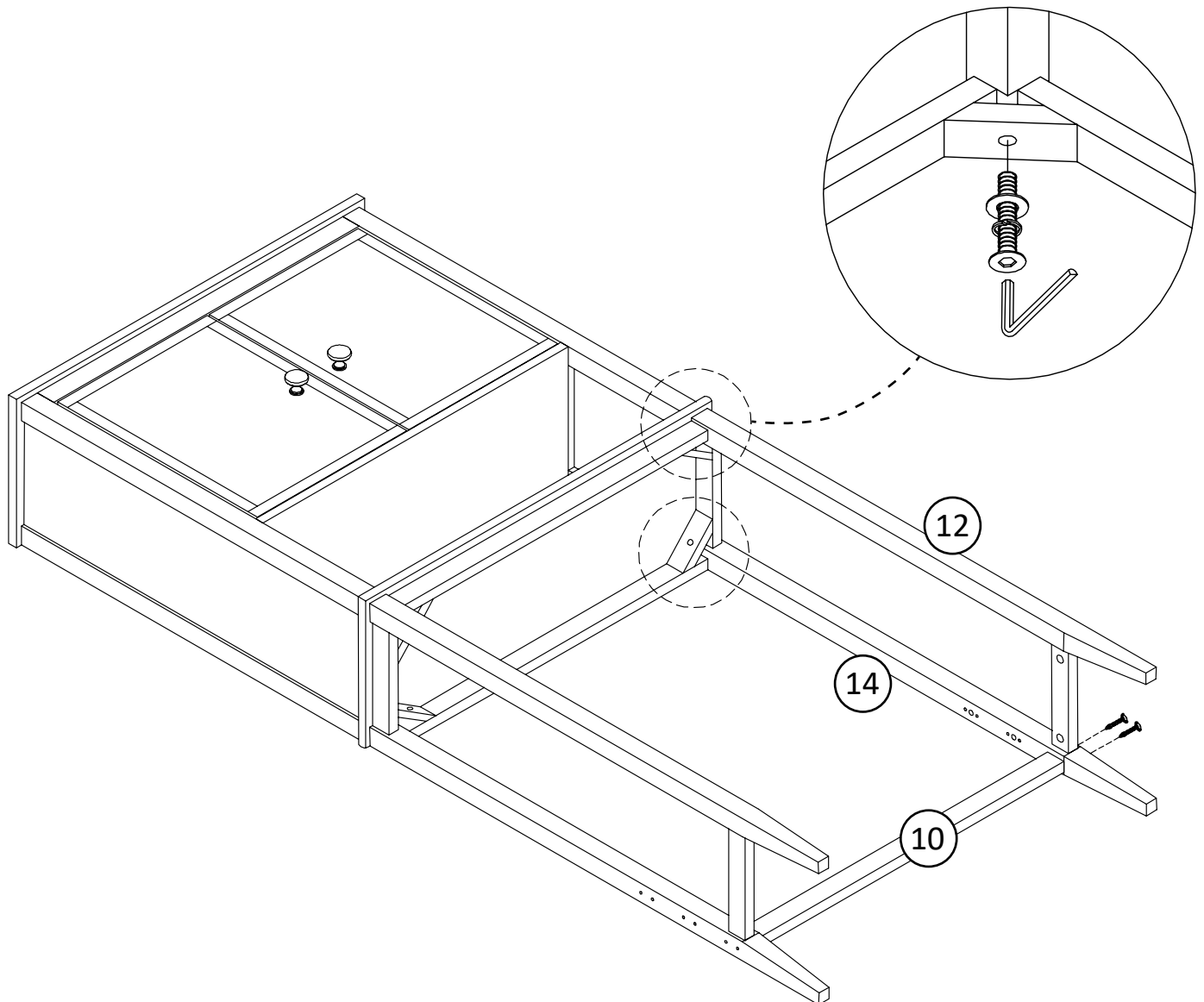

* raw edges are shaded

Step 14

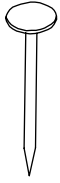
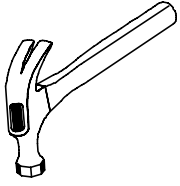

x14
TUD0006

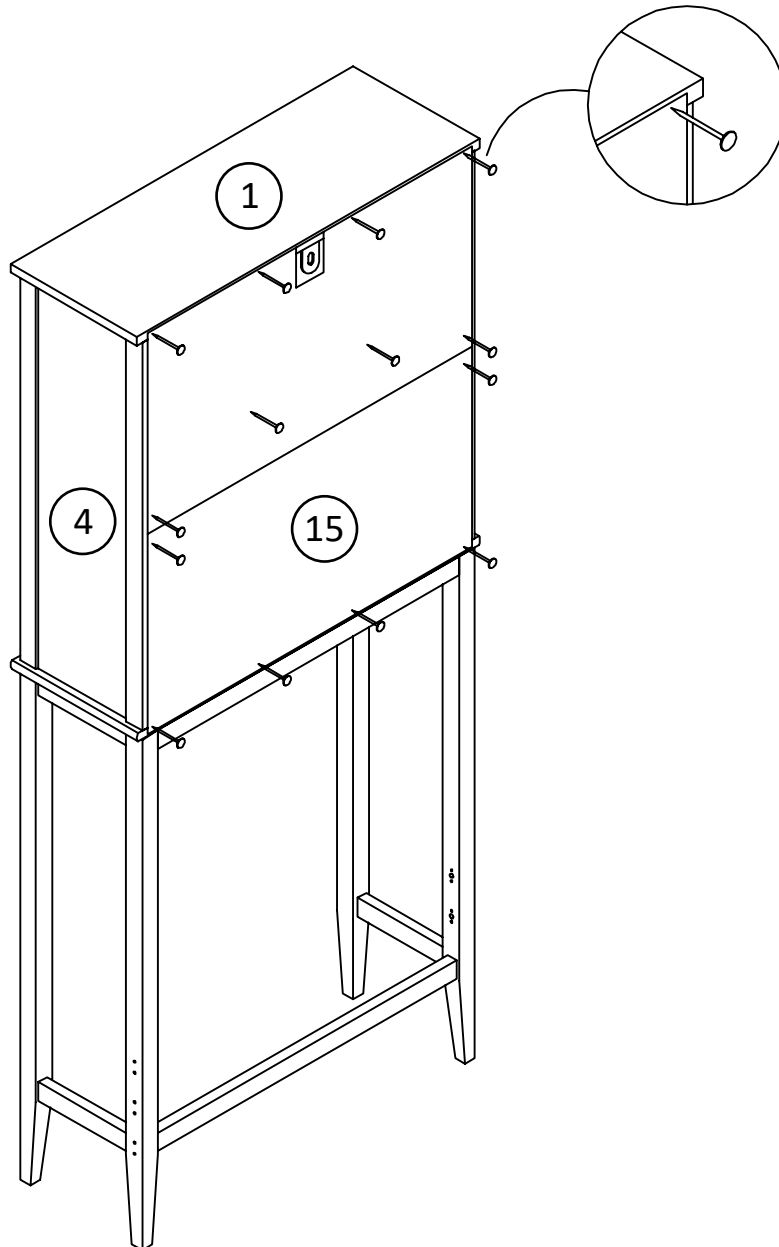

* raw edges are shaded

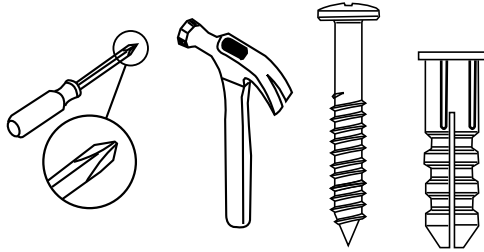

For Masonry, Concrete, or other wall materials:
Consult your local hardware store for appropriate anchors to securely attach the safety bracket.

IMPORTANT: THIS UNIT MUST BE SECURE TO THE WALL TO HELP PREVENT TIPOVER. FOLLOW THESE INSTRUCTIONS TO INSTALL THE ANTI-TIPPING SAFETY BRACKET PROVIDED WITH THIS PRODUCT.

WARNING

Serious or fatal crushing injuries can occur from furniture tip over.

To prevent tip over:

- * Install tipover restraint provided
- * place heaviest items in the lowest drawers
- * Unless specifically designed to accommodate, do not set TVs or other heavy objects on the top of this product
- * Never allow children to climb or hang on drawers, door, or shelves
- * Never open more than one drawer at a time

Use of tip over restraints may only reduce, but not eliminate the risk of tip over

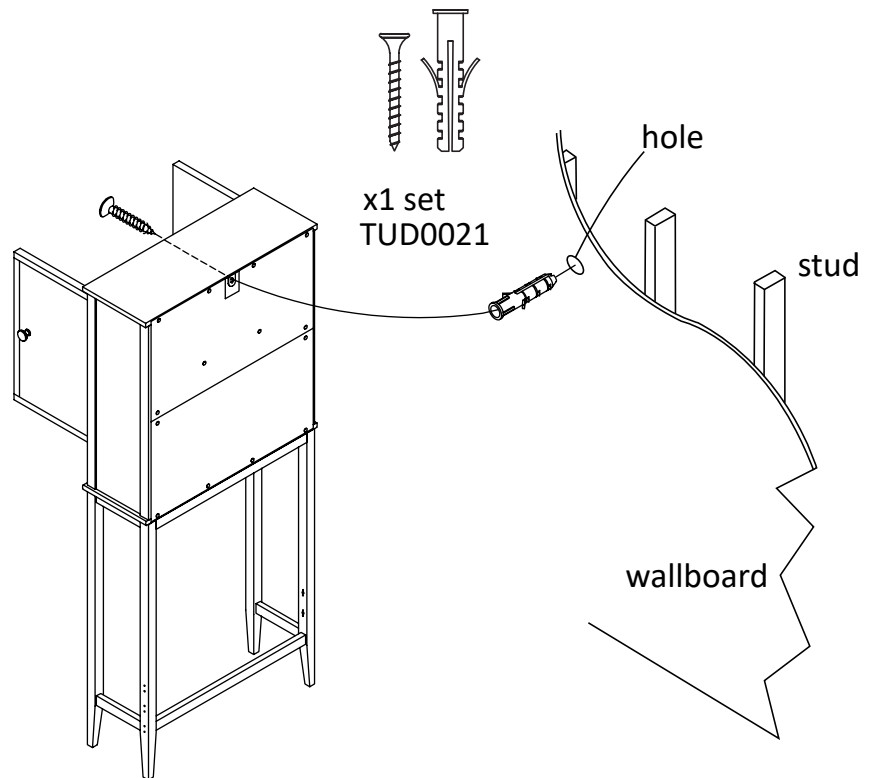

OPTION 1: Attachment into a wall stud (preferred method)

Using a stud finder, locate a stud in the wall. Place your unit against the wall, with the safety bracket aligned in this location.

To make driving the screw easier, you can drill a 1/8" diameter pilot hole (3mm) through the safety bracket into the stud.

Drive the screw through the safety bracket into the wall stud. Tighten the screw that was not fully tightened in step 5.

OPTION 2: Attachment into drywall

Locate your unit where desired against a wall and mark the wall through the safety bracket, then move your unit aside.

Drill a 3/16" diameter hole (5mm) into the wallboard. Tap the wall anchor into the hole until it is flush. Move your unit into location and fasten the wall bracket to the wall anchor with the screw.

Tighten the screw that was not fully tightened in step 5.

Maximum Loads

This unit has been designed to support the maximum loads shown. Exceeding these load limits could cause sagging, instability, product collapse, and/or serious injury.

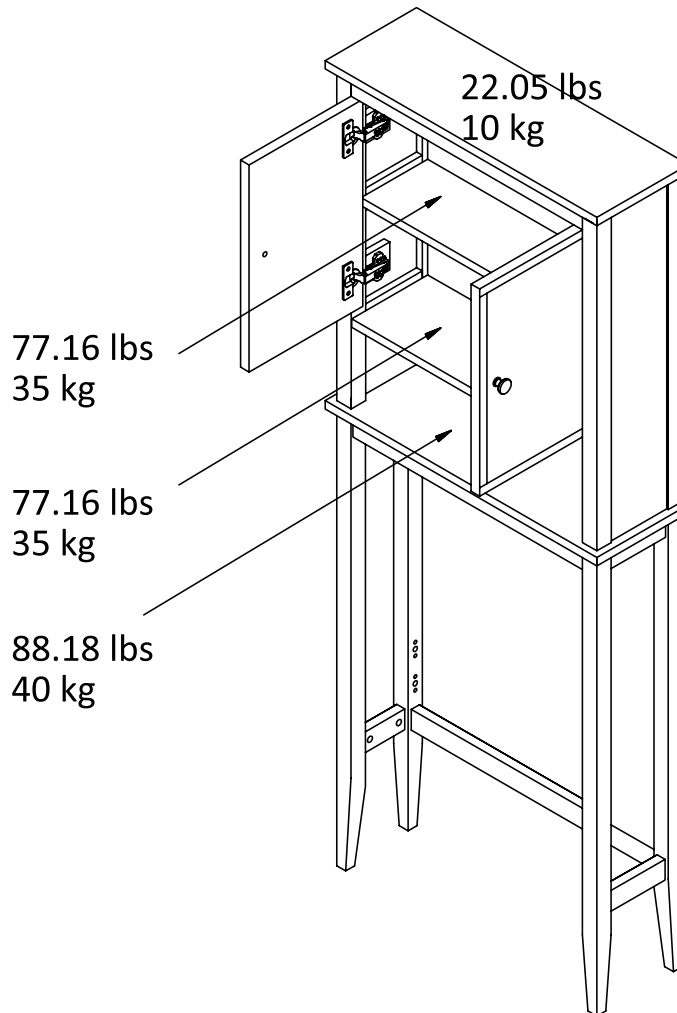

Warning: Risk of serious injury to person - do not place a television on this furniture. This furniture is not approved for use with a television.

Certificate of Confirmity

1. This certificate applies to Dorel Home Furnishings, Inc. product identified by this instruction manual.
2. This certificate applies to compliance of this product with the CPSC Ban on Lead-Containing Paint (16 CFR 1303).
3. This product is distributed by: Dorel Home Furnishings, Inc.
410 East First Street South,
Wright City, MO 63390
636-745-3351
4. Site of Manufacturer: Muar, Malaysia.
5. See front page of instruction manual for date of manufacturer.

Register your product to receive the following:



- * New trend details -sneak peek on what's new
- * Surveys -have a voice within our community
- * Exclusive deals and discount codes
- * Quick and easy replacement part service

To register your product, visit Ameriwoodhome.com

5 Star Rating



Visit your local retailer's website, rate your purchased product and leave us some feedback!

We would like to extend a big "Thank You" to all of our customers for taking the time to assemble this Ameriwood Home product, and to give us your valuable feedback

*Thank
You!*

Cubierta Delantera

Este libro de instrucciones contiene información IMPORTANTE de seguridad. Por favor lea y manténgalo para referencia en el futuro.

No Regrese este producto! Comuníquese con nuestro amistoso equipo de servicio al cliente para obtener ayuda.

Llámenos al: 1-800-489-3351 (Gratis) Lunes - Viernes 9am - 5pm CST

Visitar: www.ameriwoodhome.com

PRECAUCION

Este mueble puede volcarse y causar graves heridas y/o muerte.

Anclar el mueble a un poste de madera en la pared (si esto se requiere).

No Permita que los niños monten el mueble.

Mantenga los artículos más pesados en los cajones de abajo.

Consejos Útiles (página 2)

- Abra su artículo en el área donde usted planea utilizarlo para evitar levantar y moverlo menos
- Identificar, ordenar y contar las piezas antes de intentar ensamblar
- Las clavijas de compresión se golpean con un martillo
- Las diapositivas están marcadas con una R (derecha) y L (izquierda) para la colocación correcta
- Asegúrese de que siempre este el punto localizado en la parte superior de bloqueador de leva este volteado hacia borde exterior
- Utilizar todos los clavos para el panel de atrás y distribuirlos por igual
- El panel de atrás debe utilizarse para asegurarse de que la unidad quede fija y firme
- No use químicas fuertes ni limpiadores abrasivos en este artículo
- Nunca empuje, tire ni arrastre los muebles

Antes de Que Empieces (página 3)

- Lea cuidadosamente cada paso y siga el orden correcto
- Separar y contar todas sus piezas y hardware
- Dése suficiente espacio para el proceso de ensamble
- Tenga las siguientes herramientas: destornillador de cabeza plana, #2 cabeza Phillips Destornillador y martillo
- Precaución: Si usa un taladro electrónico o un destornillador eléctrico para atornillar, por favor asegúrese que deje de atornillar cuando el tornillos este apretado. Fallar hacer esto puede causar barrer el tornillo

Sistema de fijar el bloqueo de leva (página 3)

Esta sistema de fijar el bloqueo de leva sera usado en todo el proceso ensamble

Identificación de la Junta (página 4&5)

Tamaño no real

Lista de (página 6)

Tamaño real

Lista de (página 7)

Tamaño no real

Página 15

Para ajustar la altura vertical.

Afloje los cuatro tornillos "A" en ambas bisagras. Dos de ellos generalmente están en agujeros ranurados que le permiten ajustar hacia arriba o hacia abajo en unos pocos mm. Luego vuelve a iluminarte.

Para captar la profundidad.

Afloje el tornillo "B" y ajuste la puerta, si la puerta no se puede ajustar, afloje el tornillo "C", luego vuelva a intentarlo. Apriete el tornillo "B" y C.

Para ajustar las formas laterales.

Girando el tornillo "C" en AMBAS bisagras en cada puerta.

Página 22

Para mampostería, hormigón u otros materiales de pared:

Consulte en su ferretería local los anclajes apropiados para sujetar de forma segura el soporte de seguridad.

IMPORTANTE: ESTA UNIDAD DEBE ESTAR SEGURA EN LA PARED PARA AYUDAR A PREVENIR AL TIPOVER. SIGA ESTAS INSTRUCCIONES PARA INSTALAR EL SOPORTE DE SEGURIDAD ANTIDISCIPLINADOR PROPORCIONADO CON ESTE PRODUCTO.

ADVERTENCIA

Lesiones por aplastamiento graves o fatales puede ocurrir desde la punta del mueble. Para evitar volcar:

- * Instale la restricción de vuelco provista
- * coloque los artículos más pesados en los cajones más bajos
- * A menos que esté específicamente diseñado para acomodar, no instale televisores u otros objetos pesados en la parte superior de este producto
- * Nunca permita que los niños trepen o cuelguen de los cajones, puertas o estanterías
- * Nunca abra más de un cajón a la vez

El uso de restricciones sobre volteos solo puede reducir, pero no eliminar, el riesgo de vuelco

OPCIÓN 1: Adjunto a un montante de pared (método preferido)

Usando un buscador de pernos, ubique un perno en la pared. Coloque su unidad contra la pared, con el soporte de seguridad alineado en esta ubicación.

Para facilitar el manejo del tornillo, puede perforar un orificio piloto de 1/8 "de diámetro (3 mm) a través de la seguridad

soporte en el perno.

Introduzca el tornillo a través del soporte de seguridad en el montante de la pared. Apretar el tornillo que no estaba completamente

Tightened.

OPCIÓN 2: fijación al panel de yeso

Ubique su unidad donde desee contra una pared y marque la pared a través del soporte de seguridad, luego mueve tu unidad a un lado.

Taladre un orificio de 3/16 "de diámetro (5 mm) en el tablero. Toque el anclaje de pared en el orificio hasta que quede al ras. Mueva su unidad a su ubicación y ajuste el soporte de pared al anclaje de pared con el tornillo.

Apriete el tornillo que no estaba completamente apretado.

Página 23

ETIQUETA DE PRECAUCIÓN

CARGA MAXIMA

Esta unidad ha sido diseñada para soportar la carga máxima anotada. El exceder estos límites puede causar inestabilidad, colapsarse y/o causar serias lesiones.

Advertencia: asegúrese de quitar todos los objetos antes de mover la unidad ensamblada. La unidad debe ser levantada por más de una persona, no arrastrada o empujada. No hacerlo así lo hará causar daño al producto, inestabilidad, colapso del producto y / o lesiones graves.

Página 24

Registre su producto para recibir lo siguiente:

- * Nuevos detalles sobre las tendencias - Sneek echa un vistazo a lo nuevo
 - * Encuestas - tener una voz dentro de nuestra comunidad
 - * Ofertas exclusivas y códigos de descuento
- Servicio de piezas de repuesto rápido y fácil

Para registrar su producto, visite Ameriwoodhome.com

5 estrellas

Visite el sitio web de su distribuidor local, califique su producto comprado y déjenos algunos comentarios!

Nos gustaría extender un gran "Gracias" a todos nuestros clientes por tomarse el tiempo para montar este producto Ameriwood Home, y para darnos sus valiosos comentarios

Gracias!

* raw edges are shaded

capot avant

Ce livret d'instructions contient d'importantes informations de sécurité. S'il vous plaît lire et conserver pour référence ultérieure.

Ne pas retourner ce produit! Contactez notre équipe de service à la clientèle amical pour aider.

Appel: 1-800-489-3351 (gratuit) Lundi - Vendredi 9am - 5pm CST

Visite: www.ameriwoodhome.com

MISE EN GARDE

Ce mobilier peut basculer et causer des blessures graves et / ou la mort.

Ancrer les meubles à un poteau en bois sur le mur (si cela est nécessaire).

Ne laissez pas les enfants monter l'armoire.

Gardez les articles plus lourds dans les tiroirs ci-dessous.

Conseil (page 2)

- Ouvrez votre article dans la zone où vous prévoyez de l'utiliser pour éviter de soulever et déplacer moins
- Identifier, trier et compter les pièces avant de monter
- bouchons de compression sont frappés avec un marteau
- Les lames sont marqués par un R (droite) et L (à gauche) pour le positionnement correct
- Assurez-vous toujours ce point, je Aviana sur le dessus de la came de blocage ce bord extérieur volteadohacia
- Utilisez tous les clous du panneau arrière et les distribuer également
- Le panneau arrière doit être utilisé pour faire en sorte que l'unité est fixe et ferme
- Ne pas utiliser de produits chimiques ou de produits abrasifs sur cet article
- Ne jamais pousser, tirer ou meubles de glisser

Avant de commencer (page 3)

- Lire attentivement chaque étape et suivre l'ordre
- separate et compter toutes les pièces et matériel
- Dése un espace suffisant pour le processus d'assemblage
- Soyez les outils suivants: tournevis Phillips n ° 2 tête
Tournevis et un marteau
- Precaución: Si vous utilisez une perceuse électronique ou un tournevis électrique à vis, s'il vous plaît faire arrêter le vissage lorsque le tonillos ce serré. Le non-respect cela peut provoquer balayer la vis

Système de régler le verrou de came (page 3)

Ce système de fixation du verrou de came sera utilisé tout au long du processus d'assemblage

Identification du Conseil (page 4 et 5)

pas la taille réelle

Liste (Page 6)

taille réelle

Liste (page 7)

pas la taille réelle

page 15

Pour ajuster la hauteur verticale.

Desserrez les quatre vis "A" sur les deux charnières. Deux d'entre eux sont généralement dans des trous oblongs qui vous permettent de régler de quelques millimètres vers le haut ou vers le bas. Puis alléger.

Ackust profondeur.

Desserrer la vis "B" et ajuster la porte, si la porte ne peut pas être ajustée, desserrer la vis "C.", puis réessayer. Visser les vis "B" et C.

Pour régler les côtés.

Tourner la vis "C" sur les deux charnières de chaque porte.

page 22

Pour la maçonnerie, le béton ou d'autres matériaux muraux:

Consultez votre quincaillier local pour obtenir les ancrages appropriés afin de fixer solidement le support de sécurité.

IMPORTANT: CET APPAREIL DOIT ÊTRE SÉCURISÉ AU MUR POUR AIDER À PRÉVENIR TIPOVER. SUIVEZ CES INSTRUCTIONS POUR INSTALLER LE SUPPORT DE SÉCURITÉ ANTI-BASCULE FOURNI AVEC CE PRODUIT.

ATTENTION

Blessures graves ou fatales

peut provenir de meubles renversés. Pour éviter le basculement:

- * Installez la retenue de renversement fournie
- * placer les articles les plus lourds dans les tiroirs les plus bas
- * Sauf si spécifiquement conçu pour accommoder, ne pas placer les téléviseurs ou autres objets lourds sur le dessus de ce produit
- * Ne laissez jamais les enfants grimper ou pendre sur des tiroirs, des portes ou des étagères
- * N'ouvrez jamais plus d'un tiroir à la fois

L'utilisation de dispositifs de retenue peut uniquement réduire, mais non éliminer, le risque de basculement

OPTION 1: Fixation dans un montant mural (méthode préférée)

À l'aide d'un détecteur de goujons, localisez un goujon dans le mur. Placez votre appareil contre le mur, avec le support de sécurité aligné à cet endroit.

Pour faciliter la conduite de la vis, vous pouvez percer un trou pilote de 3 mm support dans le goujon.

Faites passer la vis à travers le support de sécurité dans le poteau mural. Serrer la vis qui n'était pas complètement serré.

OPTION 2: Fixation dans les cloisons sèches

Placez votre appareil là où vous le souhaitez contre un mur et marquez le mur à travers le support de sécurité, puis

déplacez votre unité de côté.

Percez un trou de 5 mm de diamètre dans le panneau mural. Appuyez sur l'ancrage mural dans le trou jusqu'à ce qu'il affleure. Placez votre appareil en place et fixez le support mural à l'ancrage mural à l'aide de la vis.

Serrer la vis qui n'a pas été complètement serrée.

Page 23

MISE EN GARDE

MAXIMUM DE CHARGE

Cet appareil est conçu pour supporter la charge maximale enregistrée. Le dépassement de ces limites peut provoquer l'instabilité, l'effondrement et / ou causer des blessures graves.

Avertissement: Veuillez vous assurer que tous les objets sont retirés avant de déplacer l'unité assemblée. L'unité doit être soulevée par plus d'une personne, non traînée ou poussée. Ne pas le faire causer des dommages au produit, l'instabilité, l'effondrement du produit et / ou des blessures graves.

Page 24

Enregistrez votre produit pour recevoir les éléments suivants:

- * De nouveaux détails sur les tendances - Sneek vérifier la nouvelle
 - * Sondages - ont une voix dans notre communauté
 - * Offres exclusives et des codes de réduction
- Service de pièces de rechange rapide et facile

Pour enregistrer votre produit, visitez Ameriwoodhome.com

5 étoiles

Visitez le site Web de votre distributeur local, classez votre produit acheté et laissez des commentaires!

Nous aimerions étendre un grand "Merci" à tous nos clients pour prendre le temps de rassembler ce produit Ameriwood Home et de nous faire part de vos précieux commentaires

Merci!

* raw edges are shaded