

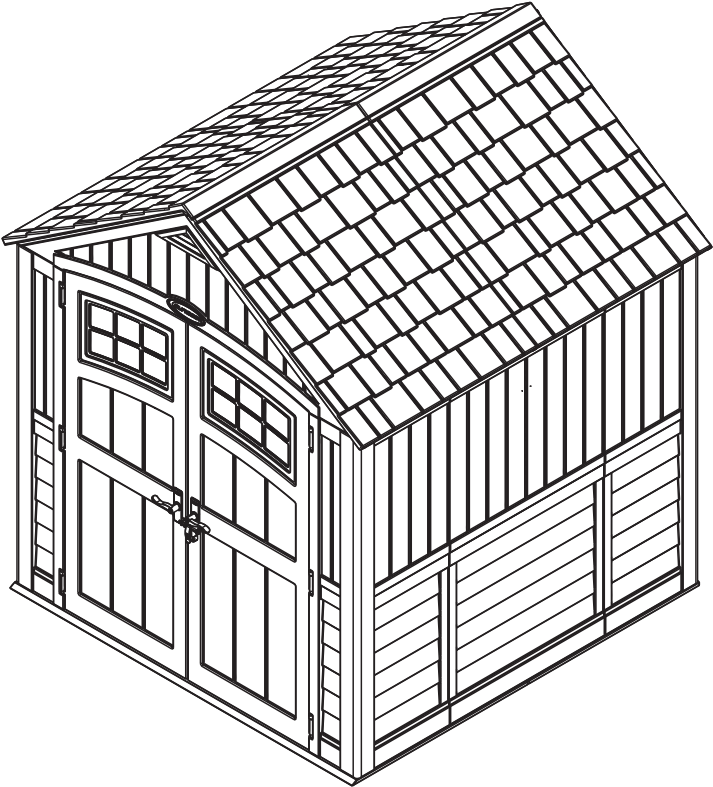

BMS7791 – Sutton™
Blow Molded Resin Storage Shed
ASSEMBLY INSTRUCTIONS

Tools needed for installation

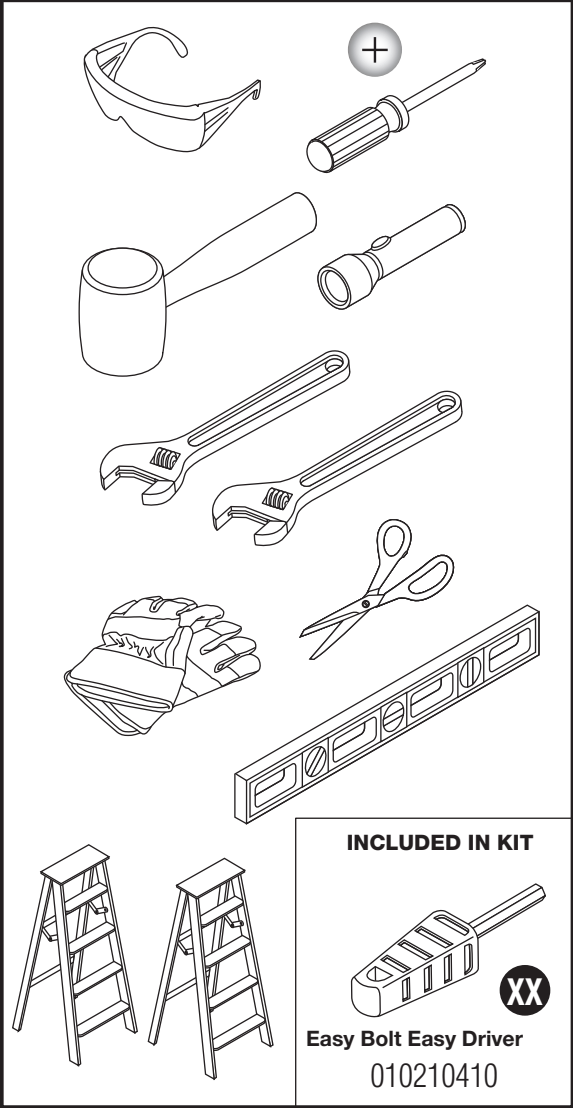

Quality Control Number:

Assembled exterior dimensions 7' 4 1/2" W. x 7' 2 1/2" D. x 8' 6" H.



Before You Begin...

- **Consult your local authorities for any permits required to construct shed.**
Prior to the construction of your shed, check with the local building code official to review any required permits or building limitations.
- **A level and sturdy foundation is required before shed construction can begin.**
Review the site preparation information within the manual before beginning assembly.
- **Read instructions thoroughly prior to assembly.**
This kit contains parts that can be damaged if assembled incorrectly or in the wrong sequence.
- **Please follow instructions.**
Suncast is not responsible for replacing parts lost or damaged due to incorrect assembly.
- **Assistance is required during entire assembly.** 

IMPORTANT

OPEN ALL BOXES FIRST AND NEATLY LAYOUT PARTS. SMALL PARTS MAY BE CONTAINED IN EACH BOX. PLEASE REFERENCE THE PARTS LIST WITHIN THIS MANUAL TO VERIFY ALL PARTS ARE PRESENT.

COMPLETE SITE PREPARATION AND FOUNDATION CONSTRUCTION BEFORE UNPACKING ALL PARTS.



Caution

- Proper site preparation required.
- Shed not intended for use in extreme weather conditions.
- Shed not intended for storage of flammable or caustic chemicals.
- Store heavy items near the bottom of shed.
- Shed not intended for use by children.
- DO NOT stand, sit, or store items on storage shed roof.
- Treat carefully in extreme temperatures.
- Repair or replace broken parts immediately.
- Suncast is not responsible for damage caused by weather or misuse.
- At regular intervals inspect your shed to make sure that assembly integrity has been maintained.
- Periodically check that the location you have chosen to set your shed is still level.
- This kit contains parts with metal edges. Please be careful when handling.

Suncast Products and Replacement Parts

To purchase Suncast replacement parts and learn about other Suncast products visit us online or call.



www.suncast.com

24 hours a day, 7 days a week, 365 days a year.



1-800-846-2345 or 1-630-879-2050



Shed Safety and Care

- Hot items, such as recently used grills, blowtorches, etc., must not be stored in the shed.
- Heavy articles should not be leaned against the walls, as this may cause panel distortion and permanent damage.
- Keep roof clean of snow and leaves.
- The shed walls and roof sections have a textured exterior, much like vinyl home siding. Over time, dust may accumulate in the texture. When combined with moisture, this could encourage the growth of moss or mold on the shed. To maintain the look of your shed, we recommend cleaning it each year with mild soap and water. **DO NOT** use bleach, ammonia, or other caustic cleaners, and **DO NOT** use stiff bristle brushes. Failure to perform annual cleaning could result in permanent staining of the plastic. This is not a manufacturing defect and is not covered under warranty.

Assembly Day Tips

- Complete site preparation and foundation construction before unpacking parts and beginning assembly.
- **DO NOT** attempt to assemble on a day with strong winds.
- **DO NOT** attempt to assemble on days when temperature is below 32 degrees.
- Set aside appropriate amount of time to completely assemble shed.
- Make sure you have assistance nearby to lift and secure parts in place.
- Wear light duty work gloves while assembling shed.
- Once roof is assembled, a flashlight may be of use when assembling smaller components inside shed.
- **DO NOT** use a torque wrench or hand drill to tighten provided Easy bolts. Use 010210410 Easy Bolt Easy Driver tool (provided) **ONLY**.
- Suncoast provides extra hardware for small fasteners for customer convenience. In some cases, there will be extra small fasteners once the assembly is complete.

Note: This product contains parts that are used in different orientations to construct the shed. Please take note of the orientation of the parts shown throughout this instruction manual. Failure to follow instructions could result in damage to parts. Suncoast is not responsible for replacing parts lost or damaged due to incorrect assembly.

IMPORTANT

OPEN ALL BOXES FIRST AND NEATLY LAYOUT PARTS. SMALL PARTS MAY BE CONTAINED IN EACH BOX. PLEASE REFERENCE THE PARTS LIST WITHIN THIS MANUAL TO VERIFY ALL PARTS ARE PRESENT.

COMPLETE SITE PREPARATION AND FOUNDATION CONSTRUCTION BEFORE UNPACKING ALL PARTS.

Parts - BMS7791 Walls and Floors

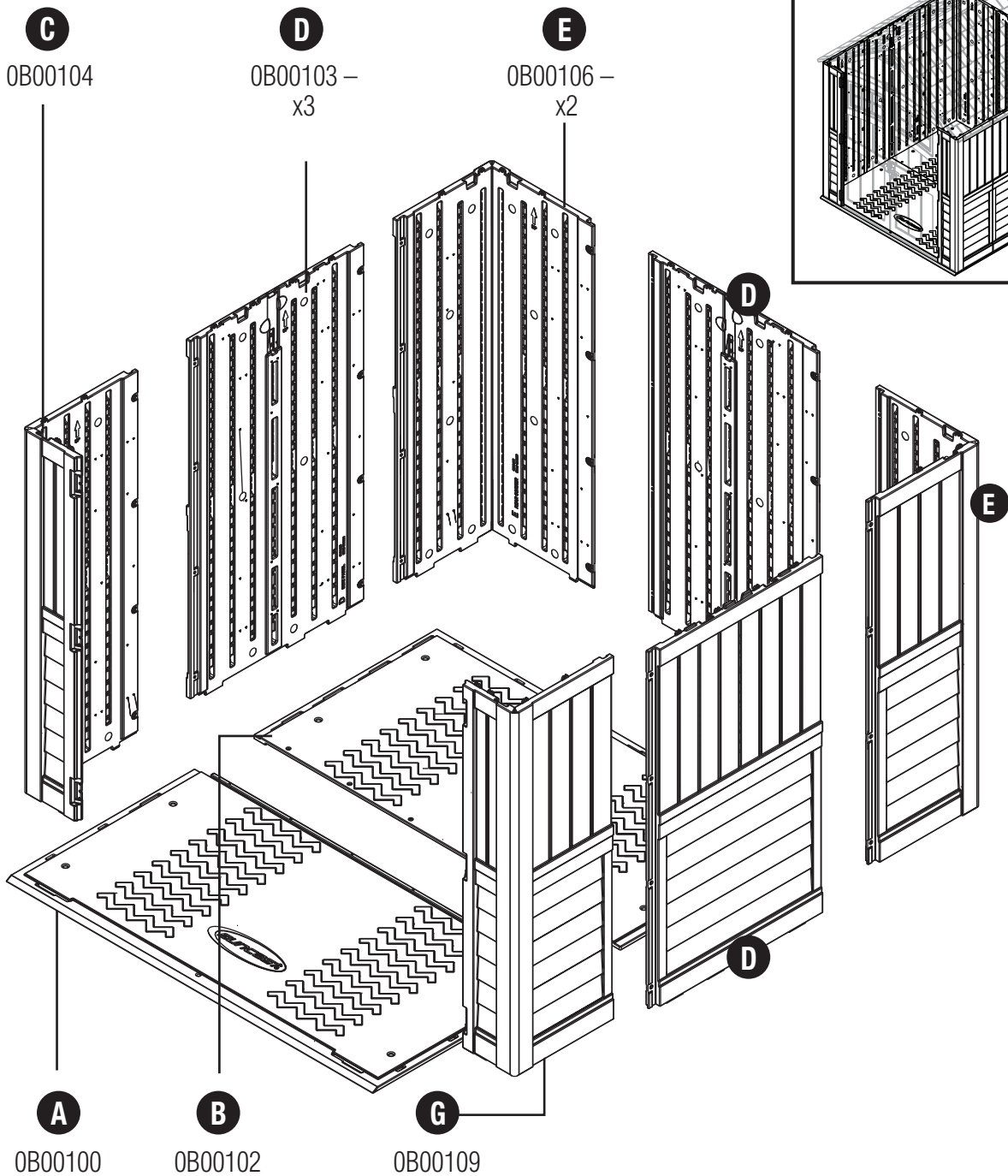

Parts - BMS7791 Doors



IMPORTANT
OPEN ALL BOXES FIRST AND NEATLY LAYOUT PARTS. SMALL PARTS MAY BE CONTAINED IN EACH BOX. PLEASE REFERENCE THE PARTS LIST WITHIN THIS MANUAL TO VERIFY ALL PARTS ARE PRESENT.
COMPLETE SITE PREPARATION AND FOUNDATION CONSTRUCTION BEFORE UNPACKING ALL PARTS.

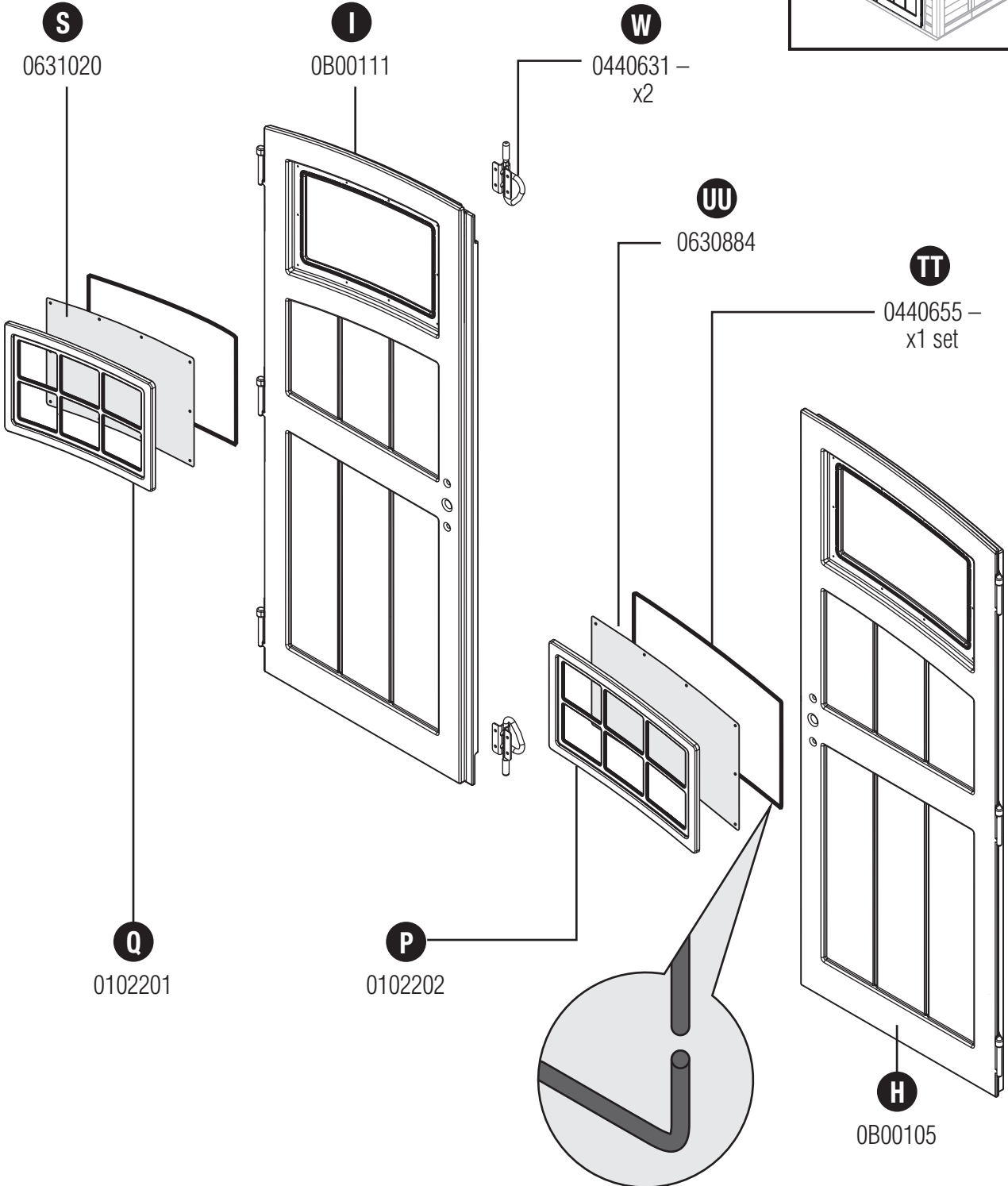

Parts - BMS7791 Headers

IMPORTANT

OPEN ALL BOXES FIRST AND NEATLY LAYOUT PARTS. SMALL PARTS MAY BE CONTAINED IN EACH BOX. PLEASE REFERENCE THE PARTS LIST WITHIN THIS MANUAL TO VERIFY ALL PARTS ARE PRESENT.

COMPLETE SITE PREPARATION AND FOUNDATION CONSTRUCTION BEFORE UNPACKING ALL PARTS.

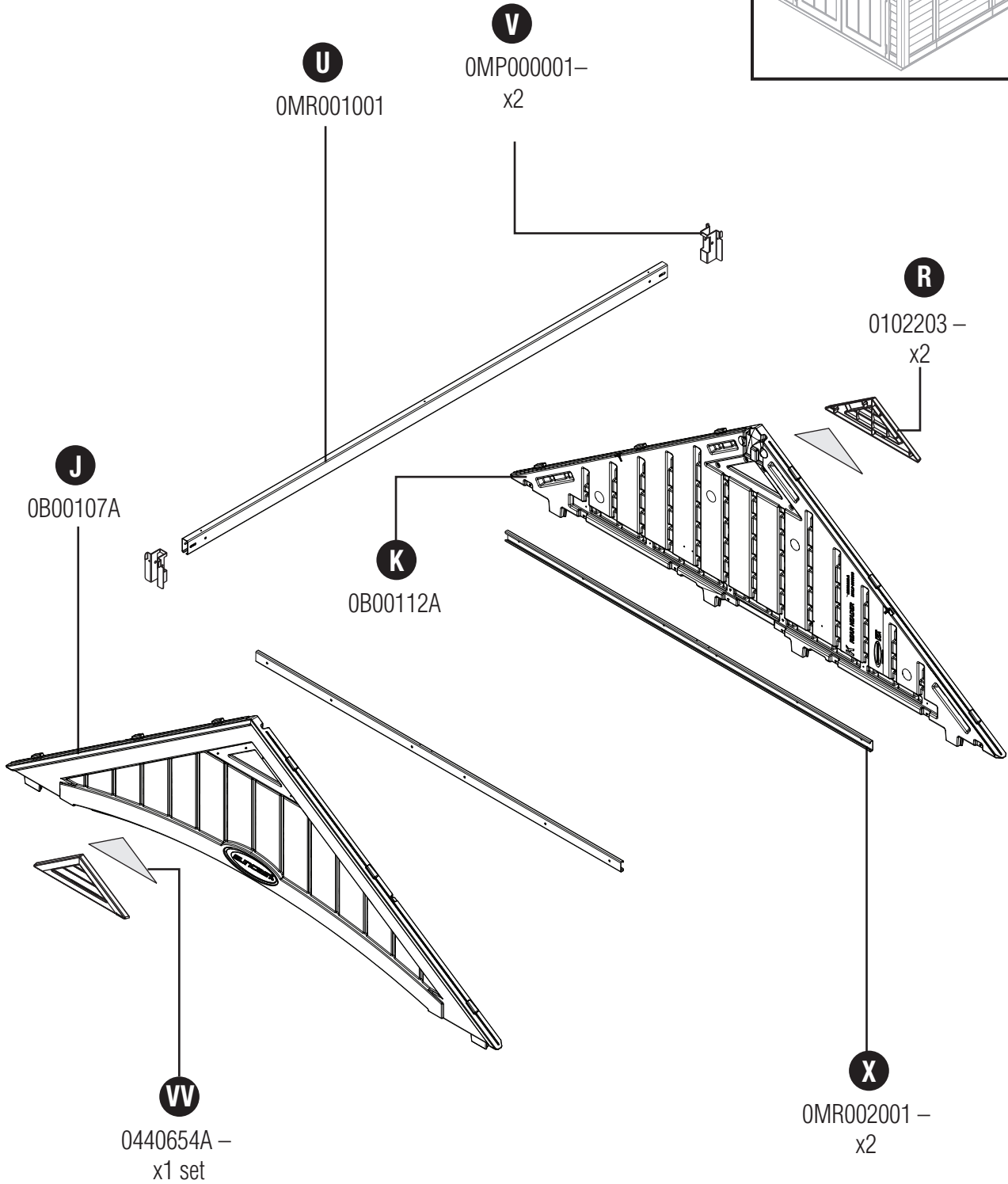

Parts - BMS7791 Roof and Truss

IMPORTANT

OPEN ALL BOXES FIRST AND NEATLY LAYOUT PARTS. SMALL PARTS MAY BE CONTAINED IN EACH BOX. PLEASE REFERENCE THE PARTS LIST WITHIN THIS MANUAL TO VERIFY ALL PARTS ARE PRESENT.

COMPLETE SITE PREPARATION AND FOUNDATION CONSTRUCTION BEFORE UNPACKING ALL PARTS.

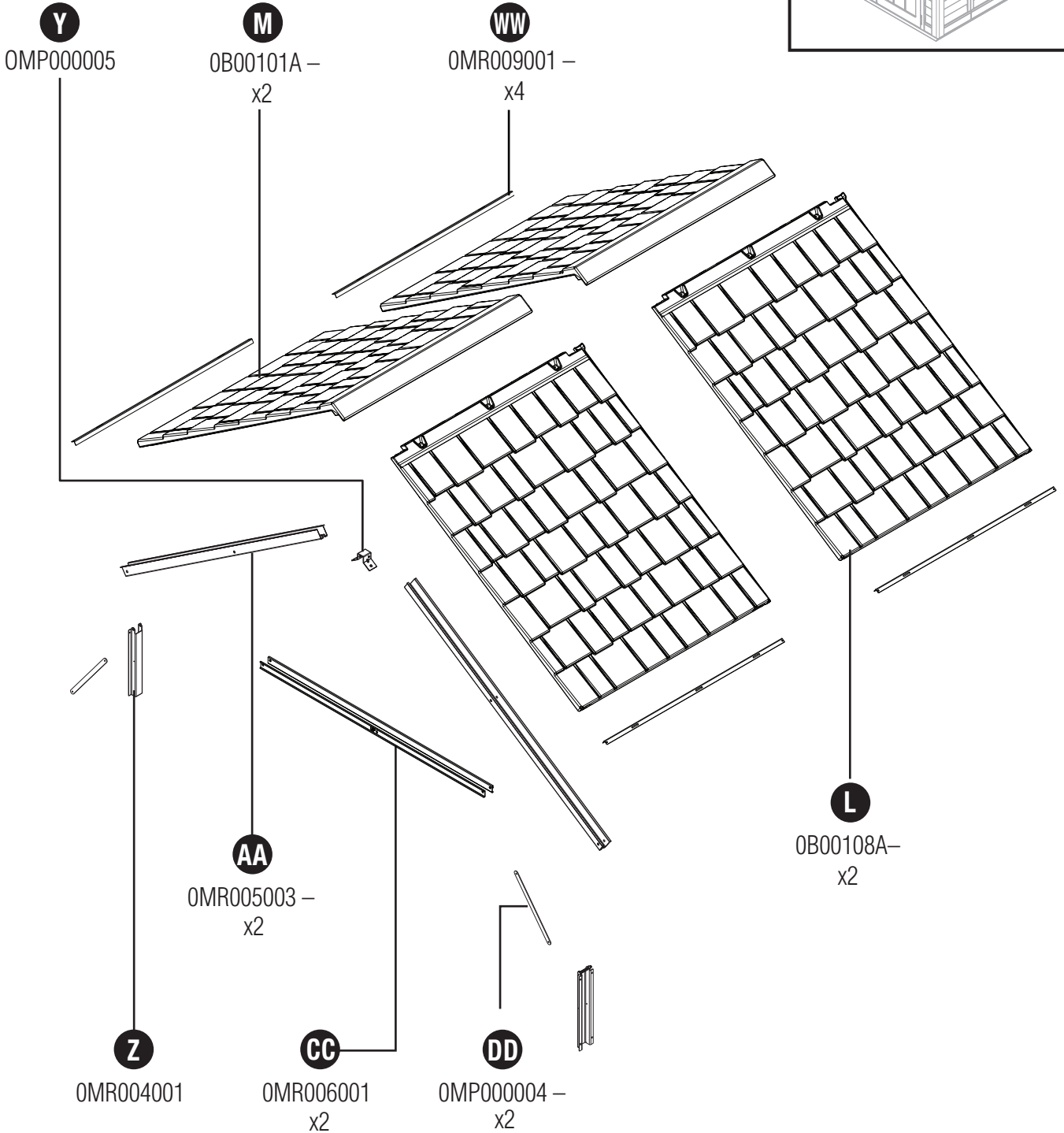

Hardware - BMS7791

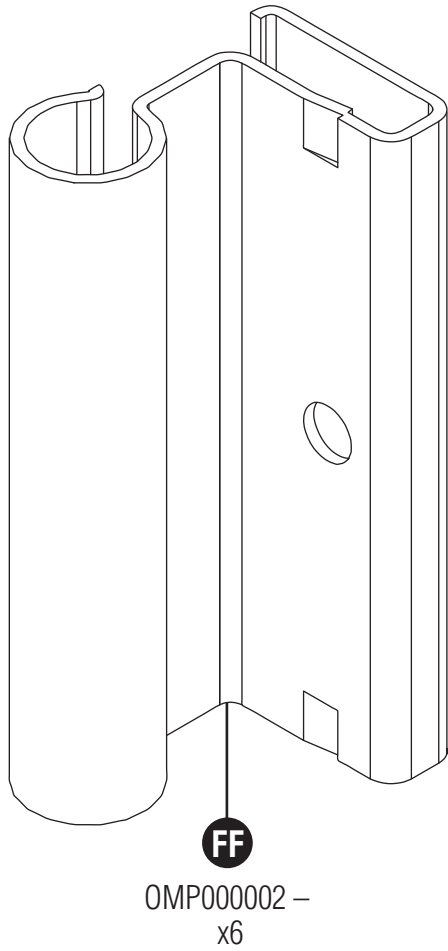

0480374

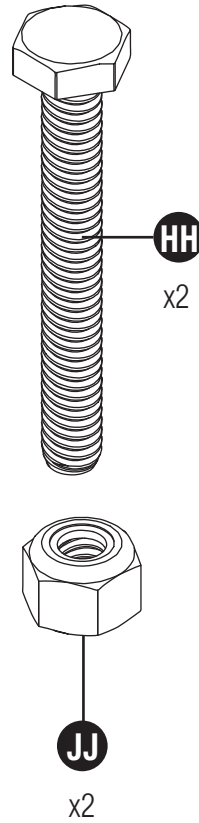

0480375

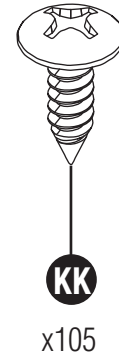

0480302A

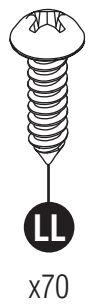

0480337



0480340

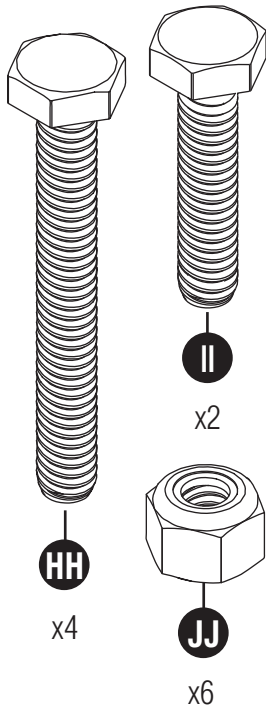

0480346

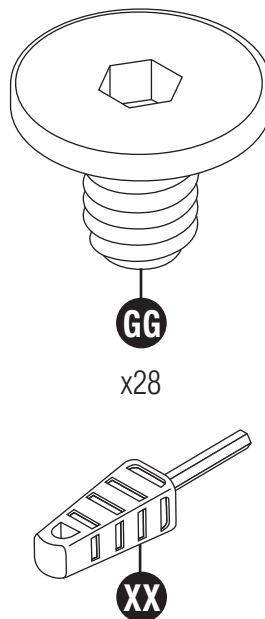

0480322

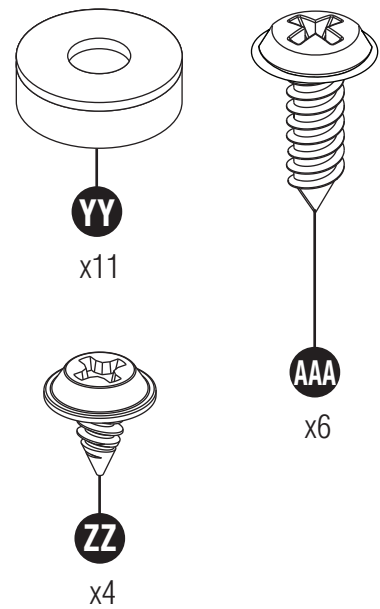

Hardware shown at actual size (*Unless otherwise noted.) Extra hardware provided. Not all are used.

Door Handle Kit - BMS7791

0440647B

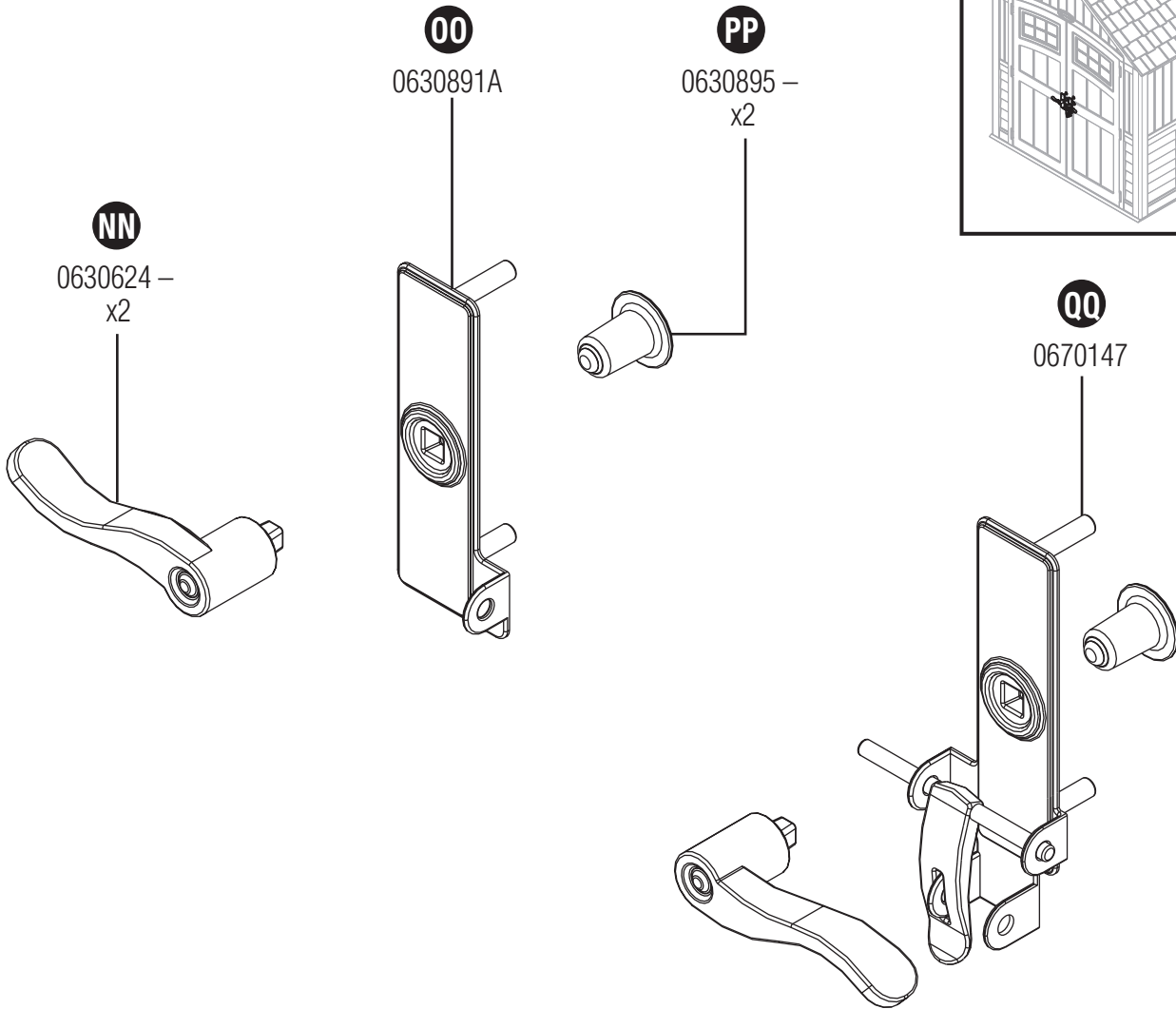
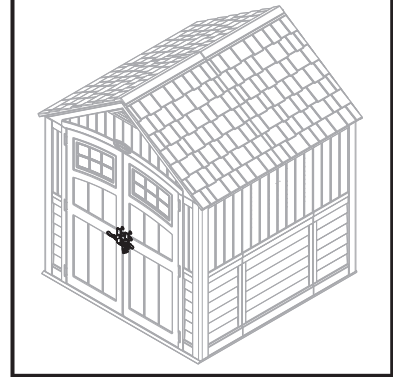

Hardware

0480306B -

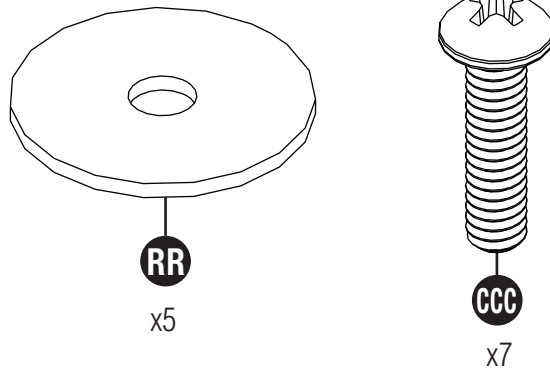

Hardware shown at actual size (*Unless otherwise noted.) Extra hardware provided. Not all are used.

Site Preparation and Platform Construction

Materials NOT supplied with BMS7791 Shed Kit

Note: Site preparation is required for this shed. Placing the shed on a constructed foundation is required. Without a constructed foundation, settling will probably occur, causing distortion and damage to the shed. Suncoast is not responsible for replacing parts damaged or property lost due to incorrect assembly. Warranty requires foundation.

Note: Complete the site preparation and foundation construction before unpacking parts and beginning assembly.

To prepare your shed site, follow the below steps:

- 1) Consult your local authorities for building codes and covenants before beginning foundation or erecting shed.
- 2) Before any digging, check with local utilities to determine location of buried cables, pipes, etc.
- 3) Decide which type of foundation you want:
 - Concrete slab, 4" thick

OR

- Wood platform

Use exterior grade wood. The wood platform should be set on pier blocks or footing. Consult your local retailer for help to determine the best anchoring method for your particular installation. The provided plans are sized for the minimum number of cuts to lumber and plywood.

- 4) Prepare the building site:
 - The ground should slope away from the foundation area to provide drainage.
 - The foundation surface must be flat and level.
 - A vapor barrier should be provided to prevent excessive condensation in the shed.
 - Follow local building codes for a proper vapor barrier.
- 5) Anchoring the shed to the foundation:
 - Consult your local retailer for help to determine the best anchoring method for your particular installation.
 - To secure the shed to a concrete slab, use masonry fasteners available at your local hardware retailer.
 - To secure the shed to a wood platform, use 1/4" x 3" long lag screws with washers.

Anchoring floor panel to concrete slab

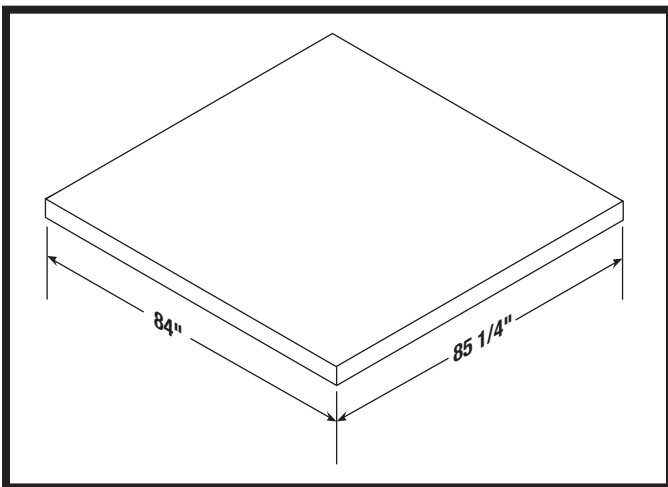

- Secure shed to concrete slab using masonry fasteners.
- Dimensions allow for shed to fit within the nearest 1" on each side.

Anchoring floor panel to wood platform

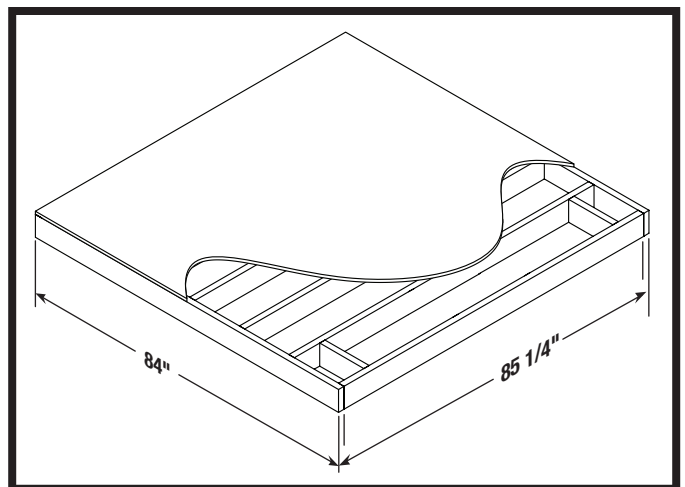

- Secure shed to wood platform using 1/4" x 3" lag screws.

Site Preparation and Platform Construction (continued)

Materials NOT supplied with BMS7791 Shed Kit

Wood platform critical spacing

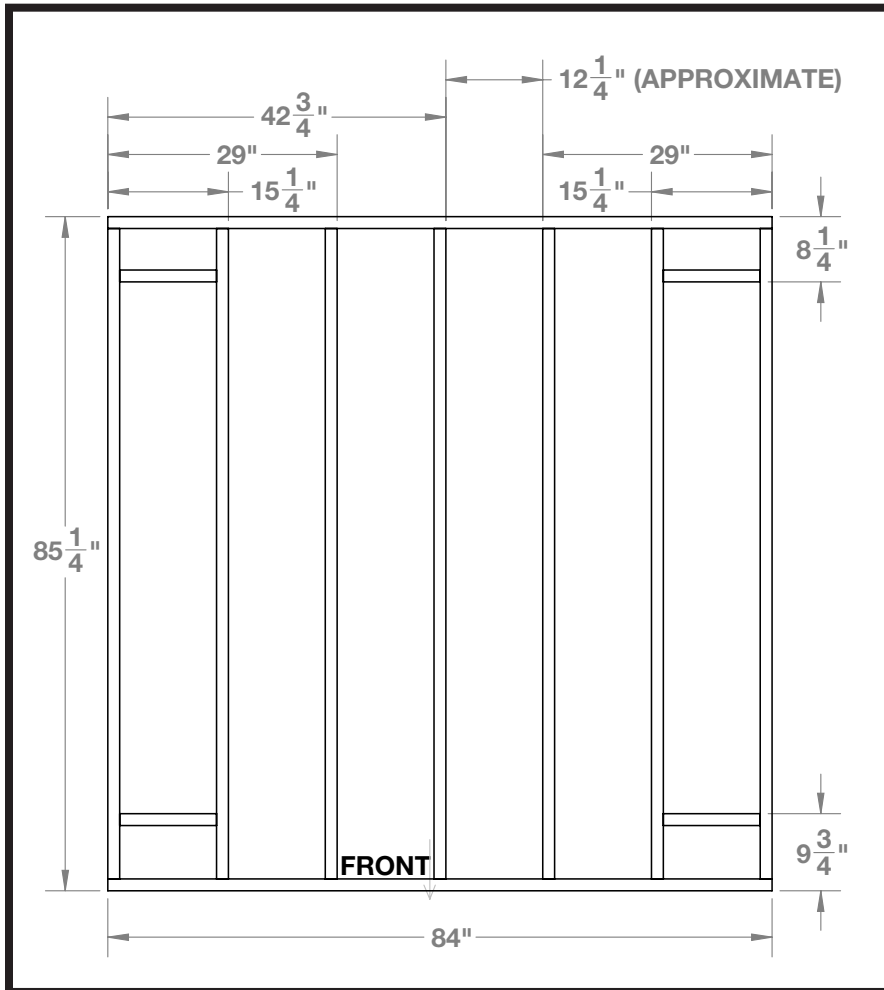

- Check all critical spacing measurements.

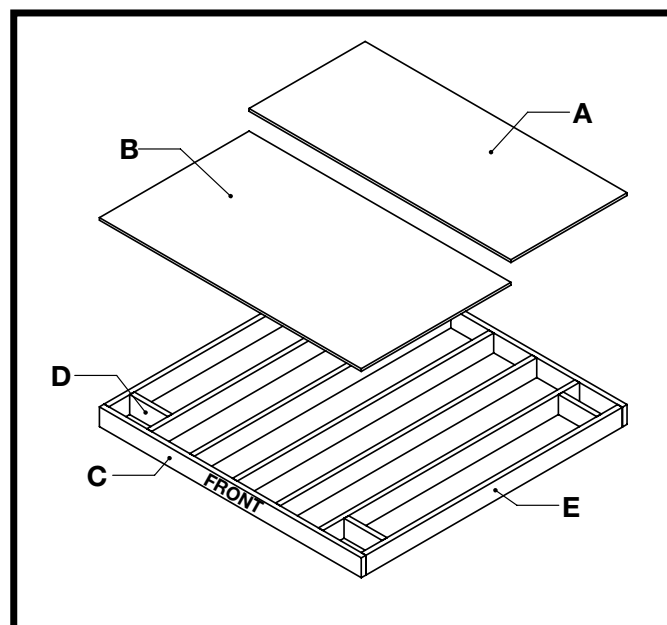

Wood platform materials list

Item	Qty	Size
A	1	37-1/4" x 84" x 3/4"
B	1	48" x 84" x 3/4"
C	2	2" x 6" x 84"
D	4	2" x 6" x 12-1/4"
E	7	2" x 6" x 82-1/4"

PLEASE NOTE - DIMENSIONAL LUMBER IS ACTUALLY 1/2" SMALLER THAN NOTED SIZES (A 2X6 BOARD ACTUALLY MEASURES 1-1/2" X 5-1/2")

Door Pre-Assembly

1

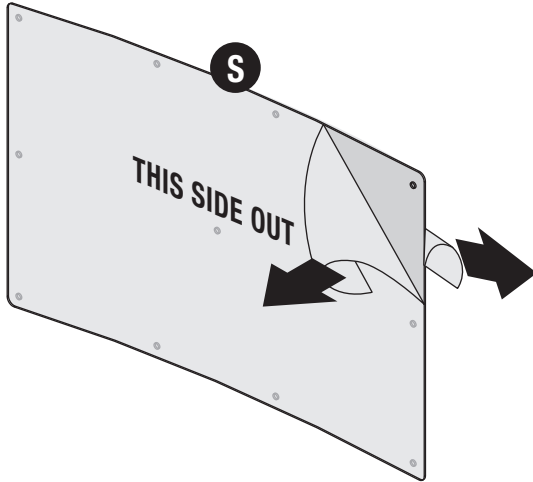

Peel film from both sides of window (S).

Note: One side of film will say "THIS SIDE OUT." Make sure this side faces out when installing window.

2

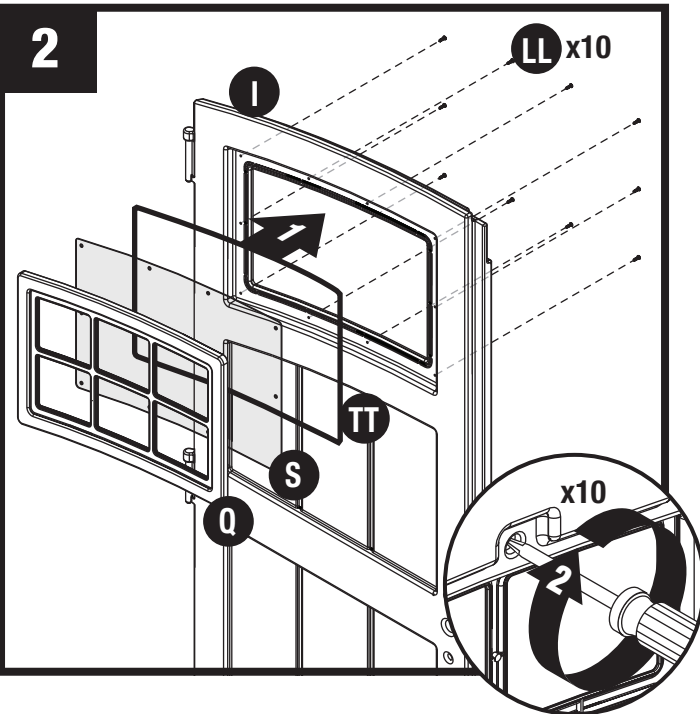

Stand left door (l) vertically. In this order, layer into door channel the window gasket (TT), door window (S), and door window frame (Q). Through the back of door, secure layers with ten screws (LL). Start with four corner screws and finish with remaining screws. **DO NOT** over tighten screws.

Note: The cut portion of window gasket (TT) **MUST** be assembled on bottom of door channel.



Note: At least two people are needed during assembly.

Door Pre-Assembly (continued)

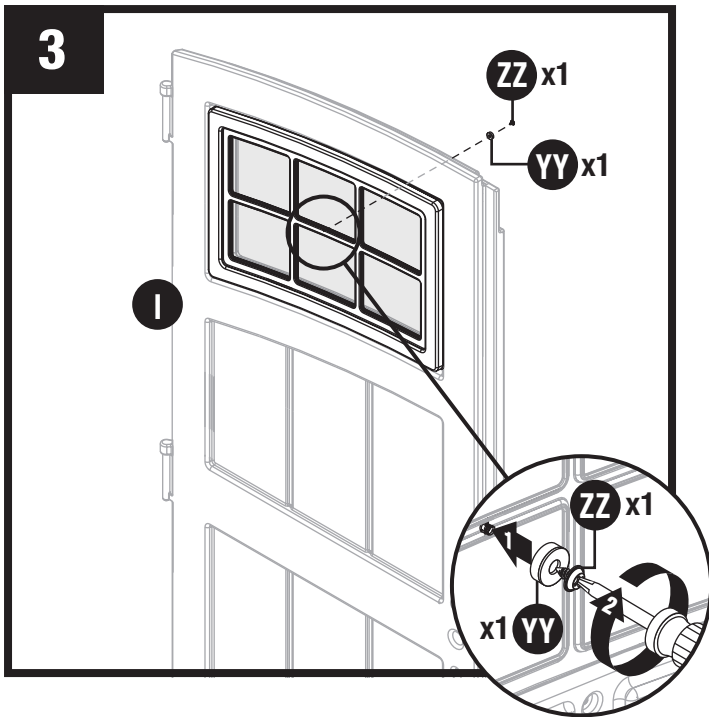

Secure center of window with one washer head screw (ZZ) and sealing washer (YY). **DO NOT** over tighten screws.

Repeat on Steps 1-3 for right door (H).



Note: At least two people are needed during assembly.

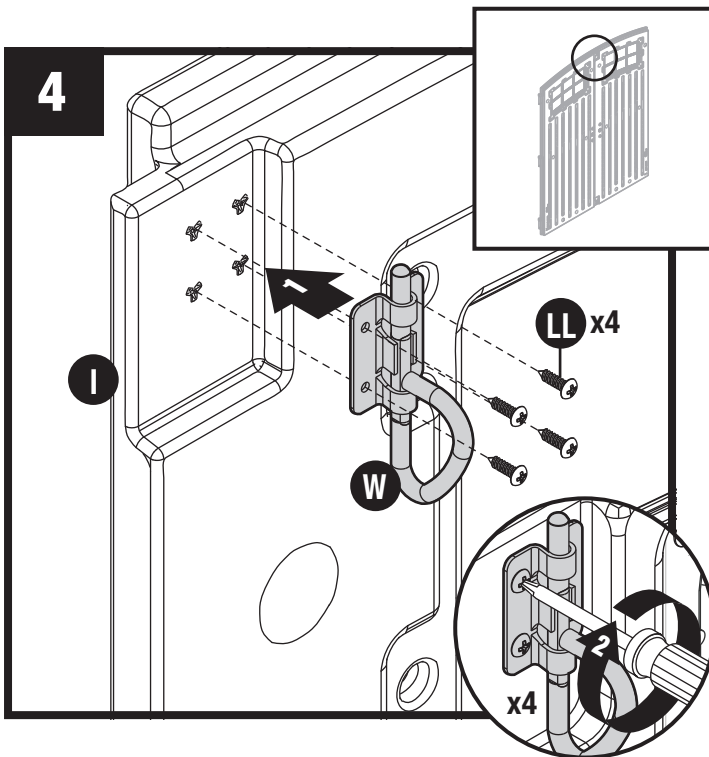

At top interior side of left door (I), attach D-ring slide bolt (W) with four screws (LL) through provided holes.

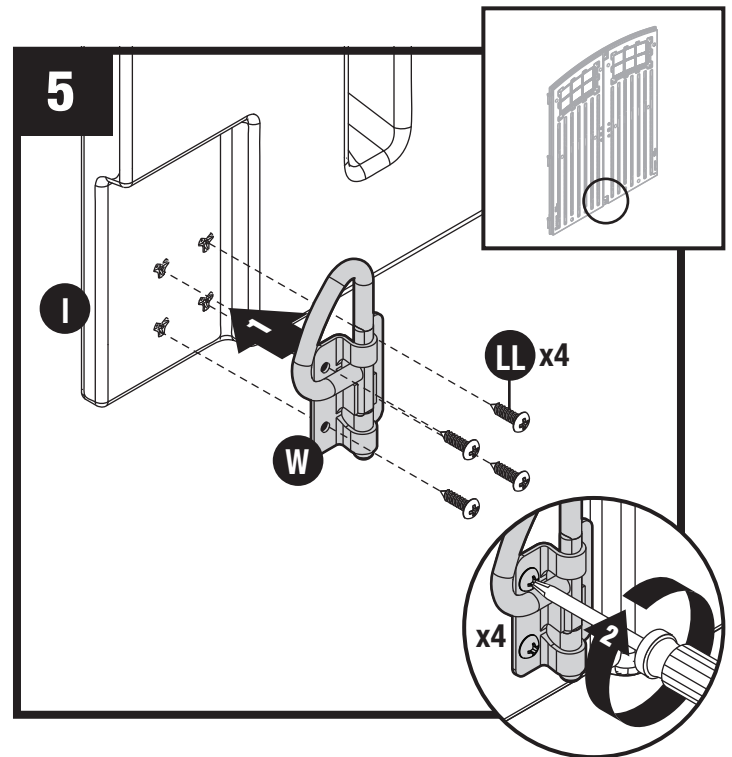

At bottom interior side of left door (I), attach D-ring slide bolt (W) with four screws (LL) through provided holes.

Header Pre-Assembly

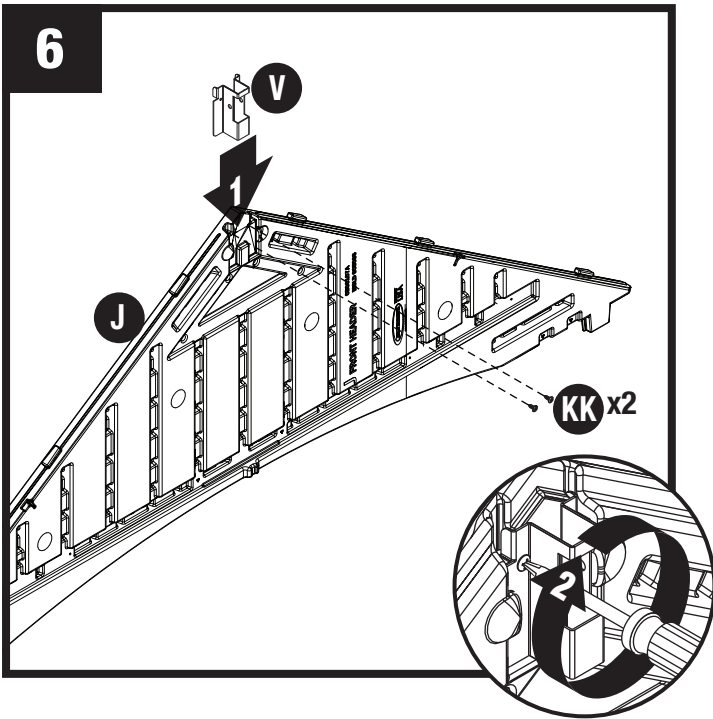

Slide roof ridge beam bracket (V) under tabs on inside peak of front header (J) and secure with two screws (KK). **DO NOT** over tighten screws.

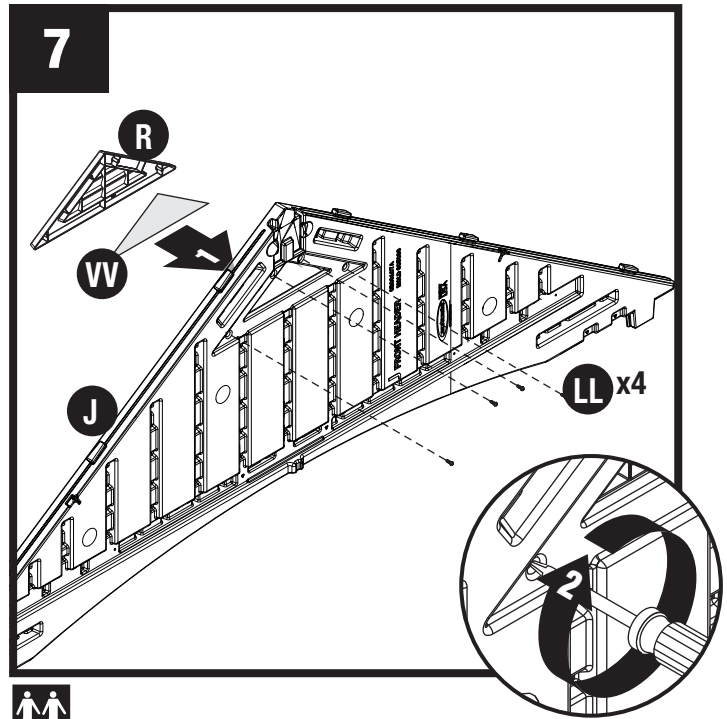

Place fiberglass vent screen (VV) and header vent (R) into front opening in front header (J). Secure through back of header with four screws (LL). **DO NOT** over tighten screws.

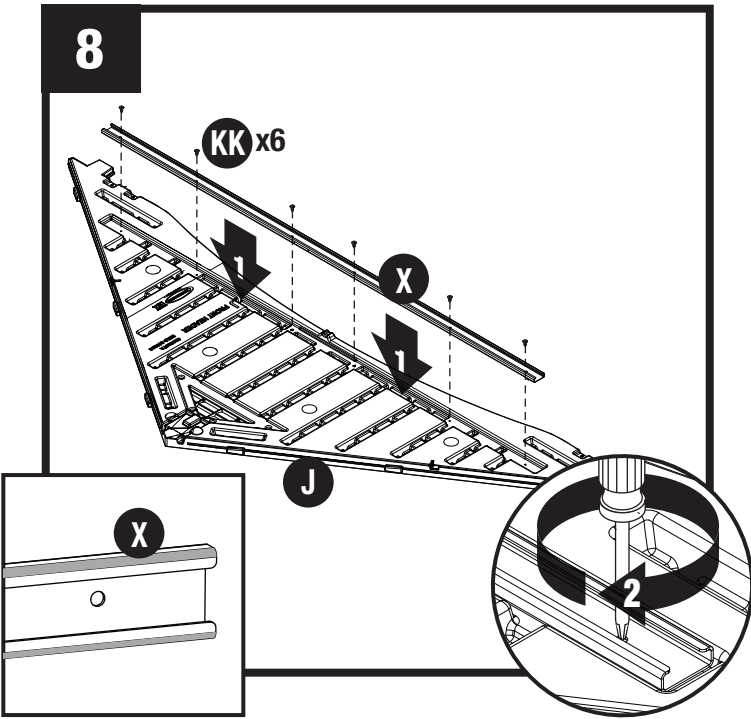

Lay header (J) on ground with lettering side facing up. Place one header beam (X) into pocket on inside of front header (J). Attach with six screws (KK). **DO NOT** over tighten screws.

Repeat steps 6-8 for rear header (K).

Truss Pre-Assembly

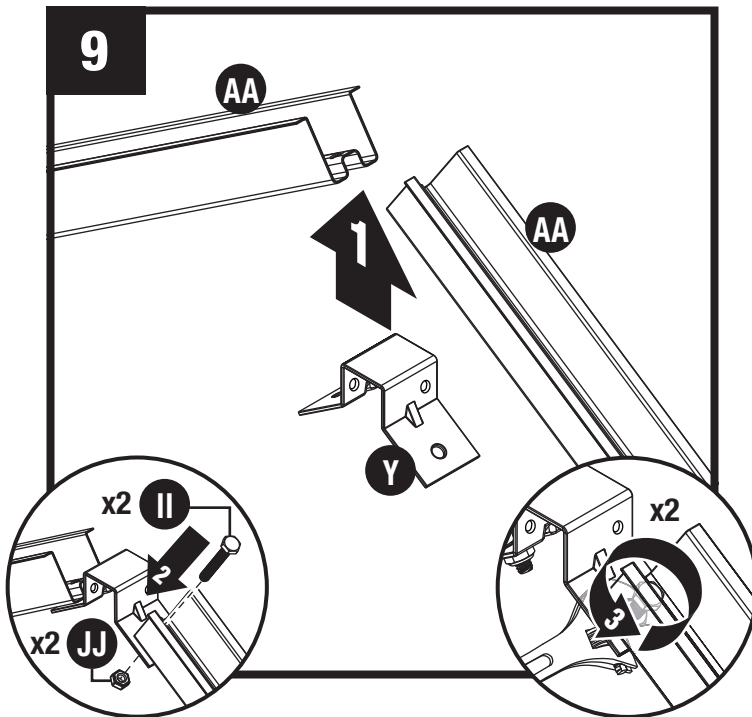

Attach truss bracket (Y) to end of one truss leg (AA) with 1" hex head cap screw (II) and nut (JJ). Repeat for second truss leg (AA).

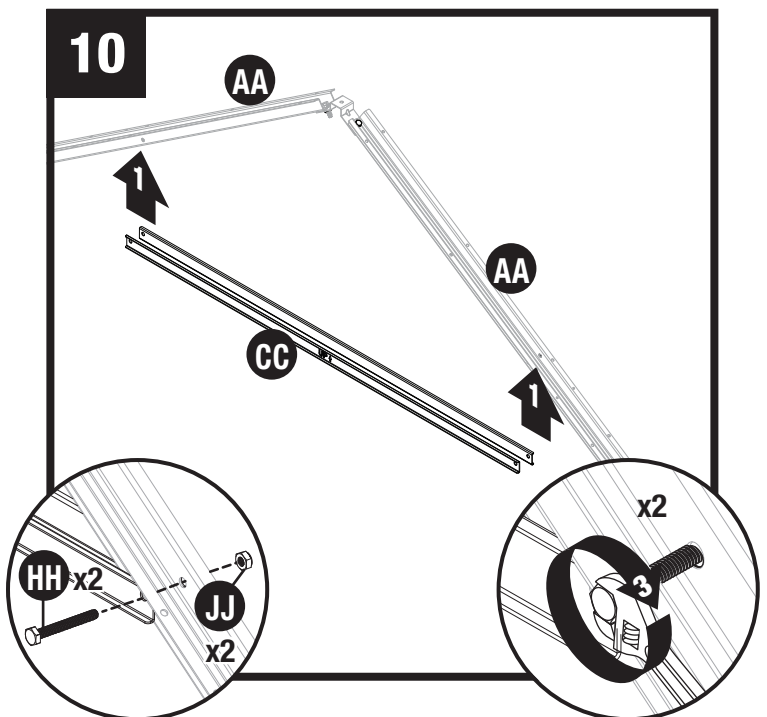

Attach truss cross beam (CC) to two truss legs (AA) using two hex head cap screws (HH) and two nuts (JJ). Stand truss and check cross beam is level.

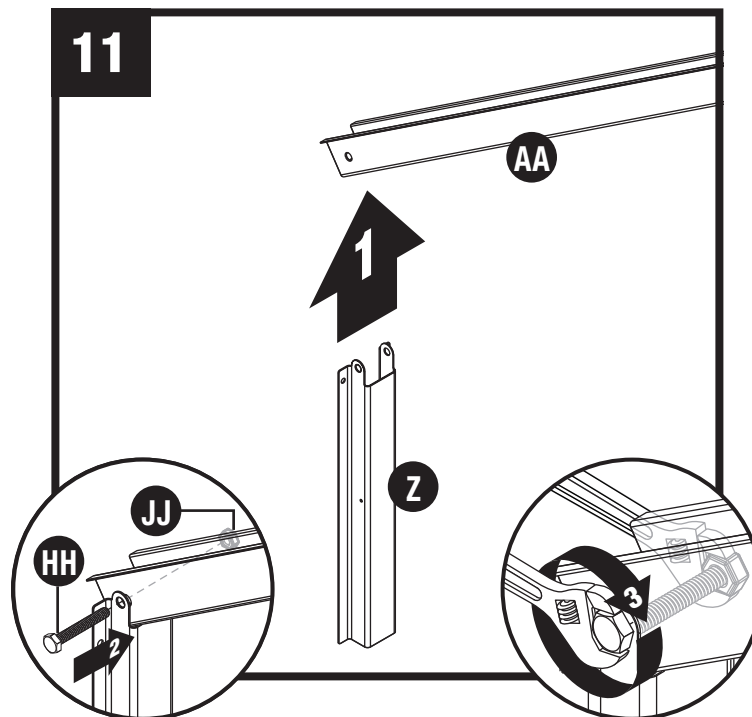

Place side adaptor bracket (Z) at end of left truss leg (AA). Secure adaptor bracket with one 2" hex head cap screw (HH) and one nut (JJ).

Note: DO NOT over tighten side adaptor bracket (Z) onto end of truss legs (AA). This makes roof assembly difficult.

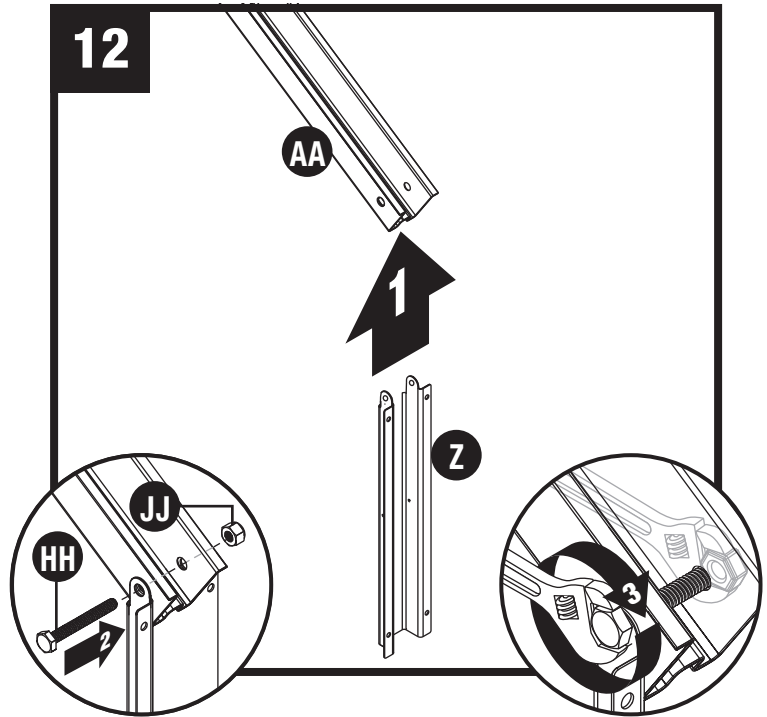

Place window truss tie down (Z) at end of right truss leg (AA). Secure truss tie down with one 2" hex head cap screw (HH) and one nut (JJ).

Note: DO NOT over tighten truss tie down (Z) onto end of truss legs (AA). This makes roof assembly difficult.

Shed Assembly/Walls

13



Critical: When installing corners, flex corner hinges back and forth several times. This will help provide a square corner and ensure proper fit of remaining panels.

Important: DO NOT flex in reverse position, as this can crack the panel.

14

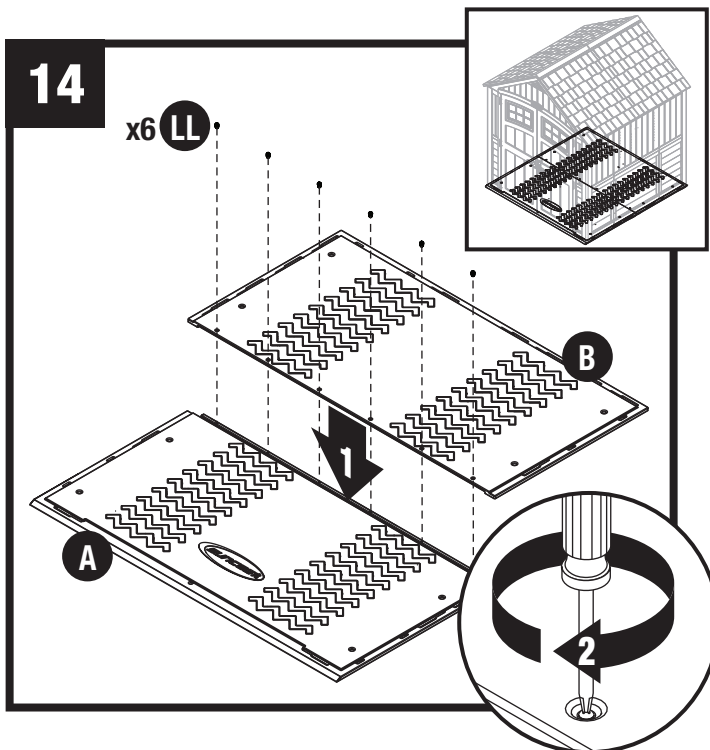

Push front floor (A) and rear floor (B) panels together and secure with six screws (LL).

Note: Refer to pages 10 and 11 to secure floors to foundation.

15

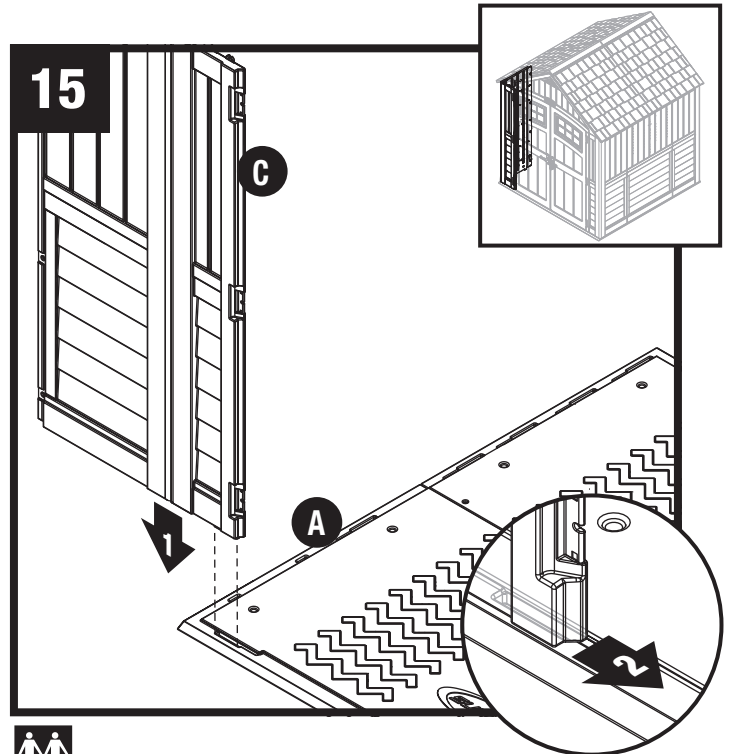

Align tab on bottom right side of left front (C) with slot on front floor (A). Lower panel into slot and lock in place by sliding panel toward door opening.

Note: Use a rubber mallet to “push” left front corner (C) into locked position.

Shed Assembly/Walls (continued)

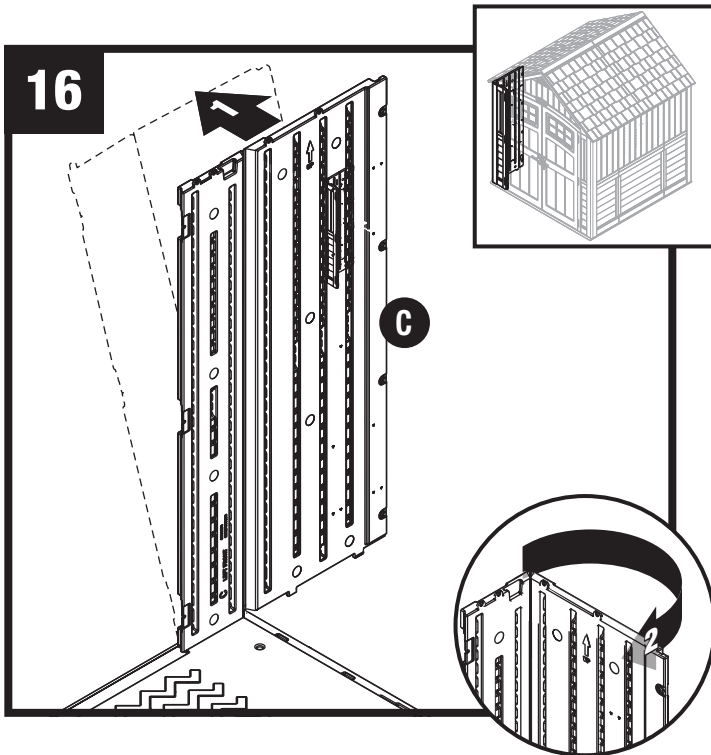

Tip left front (C) outward slightly and bend corner hinge.

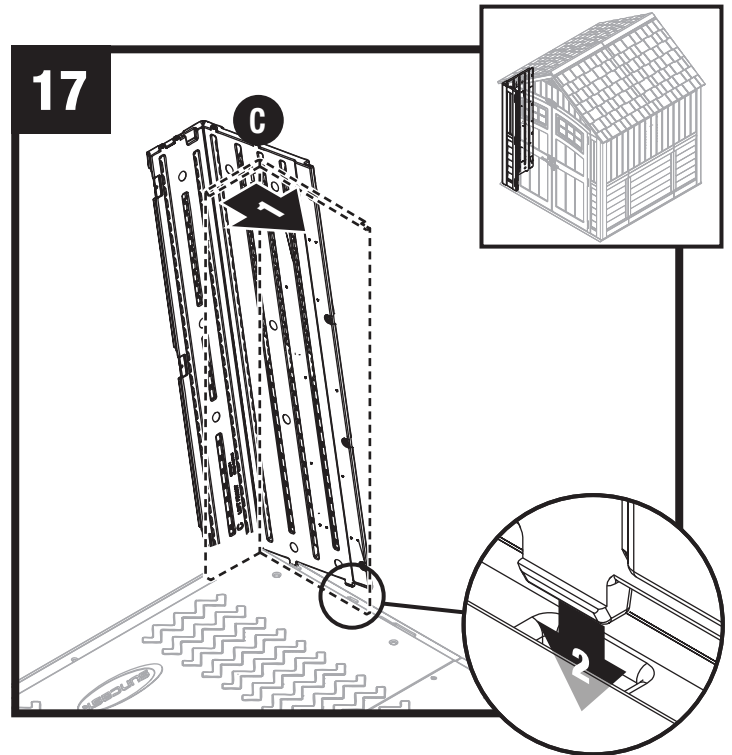

Tip left front (C) back to vertical position and align lower tabs on right side with slots in floor.

Note: You will hear a snap when tab is fully engaged.

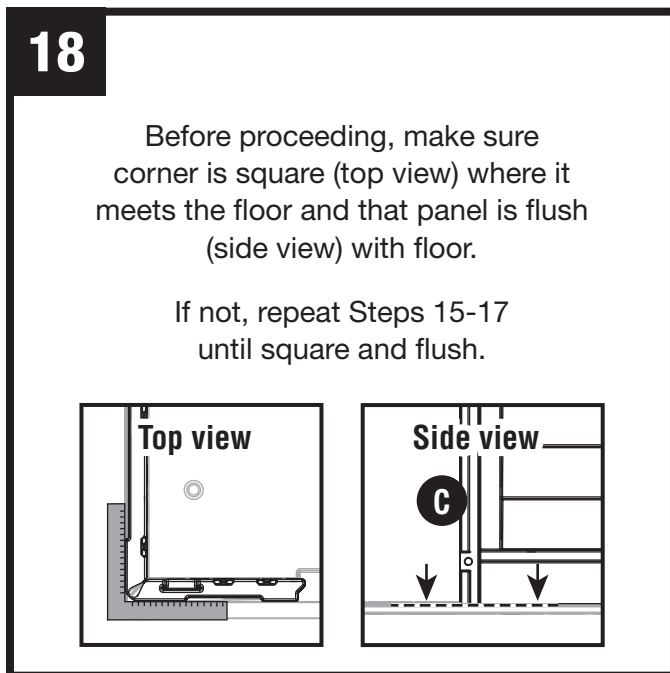

Shed Assembly/Walls (continued)

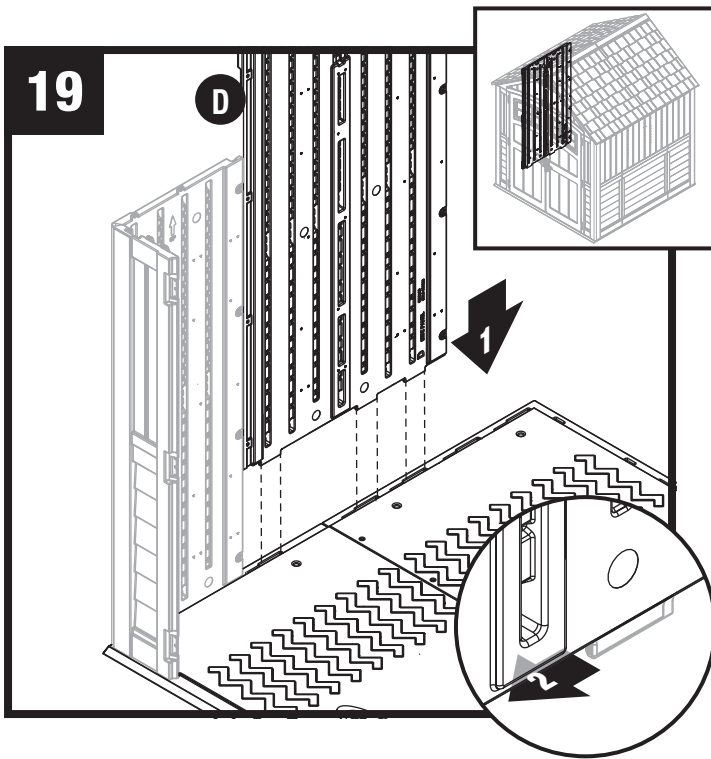

Align tabs on bottom of side panel (D) with slots along front and rear floors. Lower panel into slots and lock in place by sliding panel toward front corner.

 **Note:** Use a rubber mallet to “push” side panel (D) into locked position.

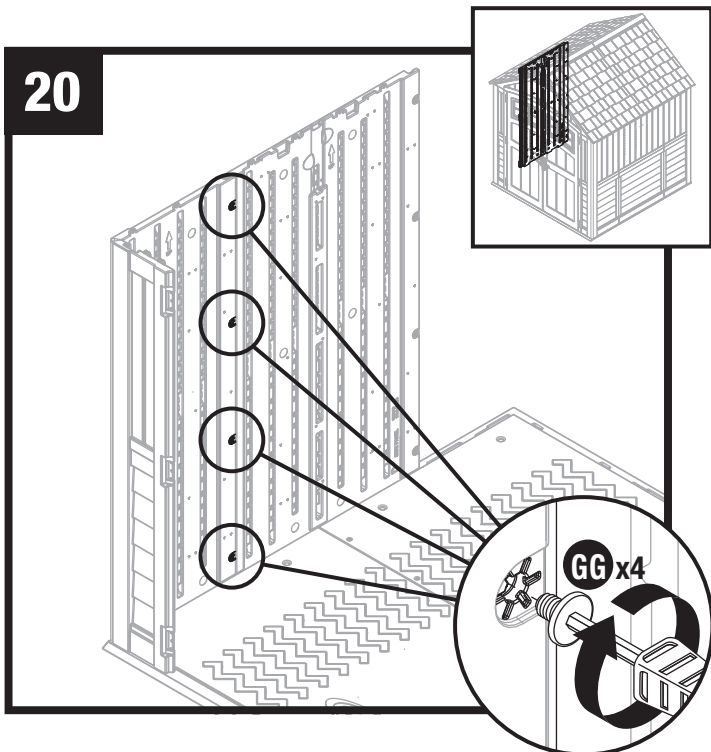

Secure side panel with four easy bolts (GG), working from floor to roof. **DO NOT** use torque wrench. Use easy bolt easy driver (XX) and hand tighten. Easy bolt head will be flush when fully seated. **DO NOT** over tighten easy bolts.

Note: You may hear a click when easy bolt has been tightened completely.

21

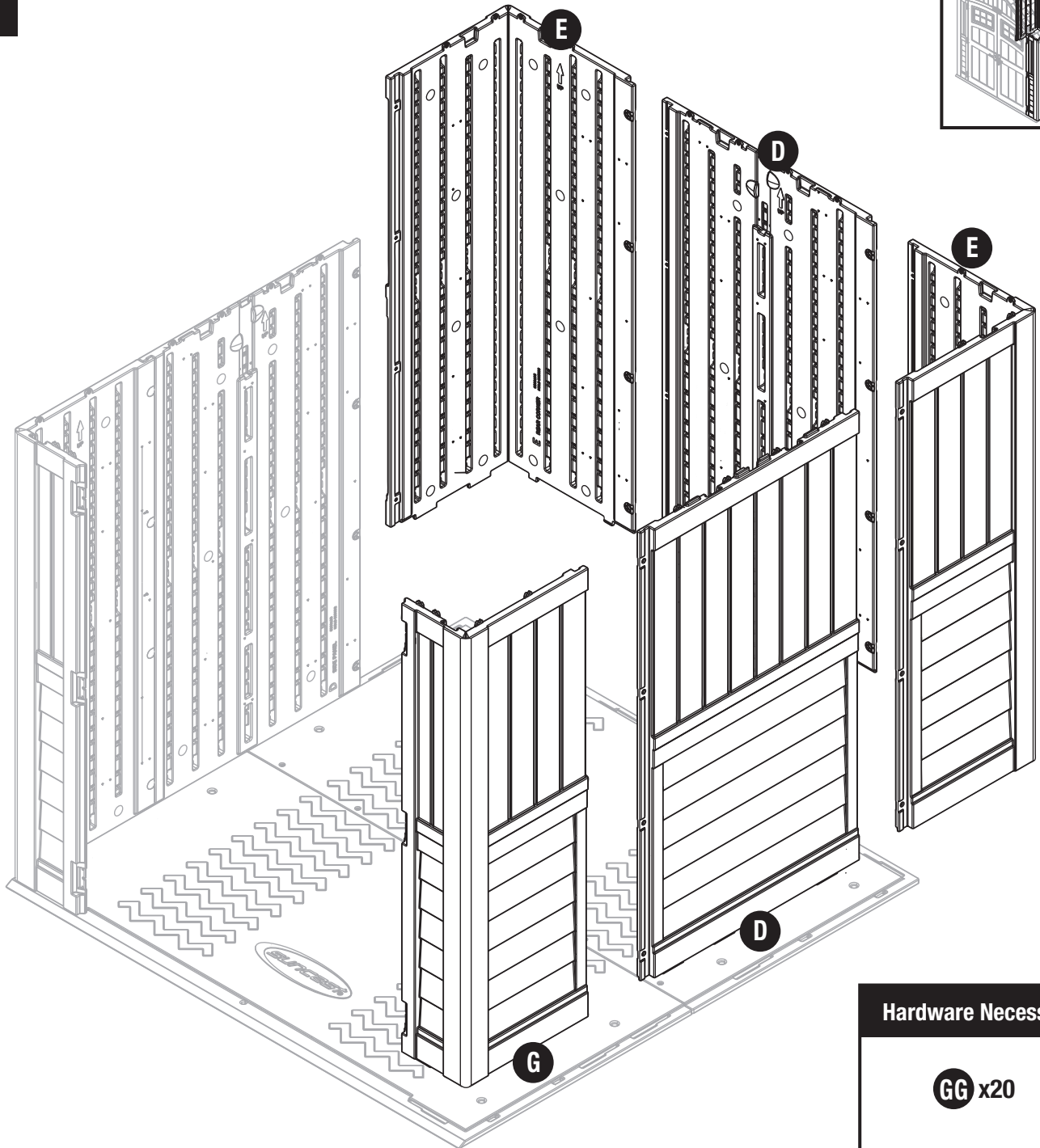
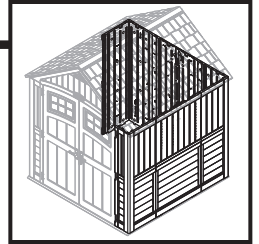

Repeat Steps 15-20 for remaining panels.

Shed Assembly/Headers and Truss

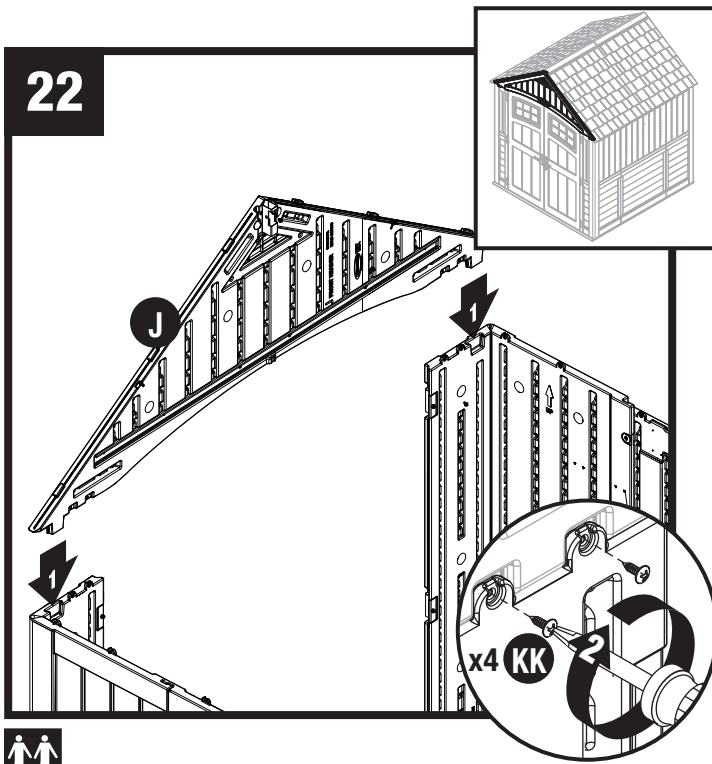

Place front header (J) over door opening and fit two protruding support legs into pockets molded in front corners. Secure front header using two screws (KK) in each front corner.

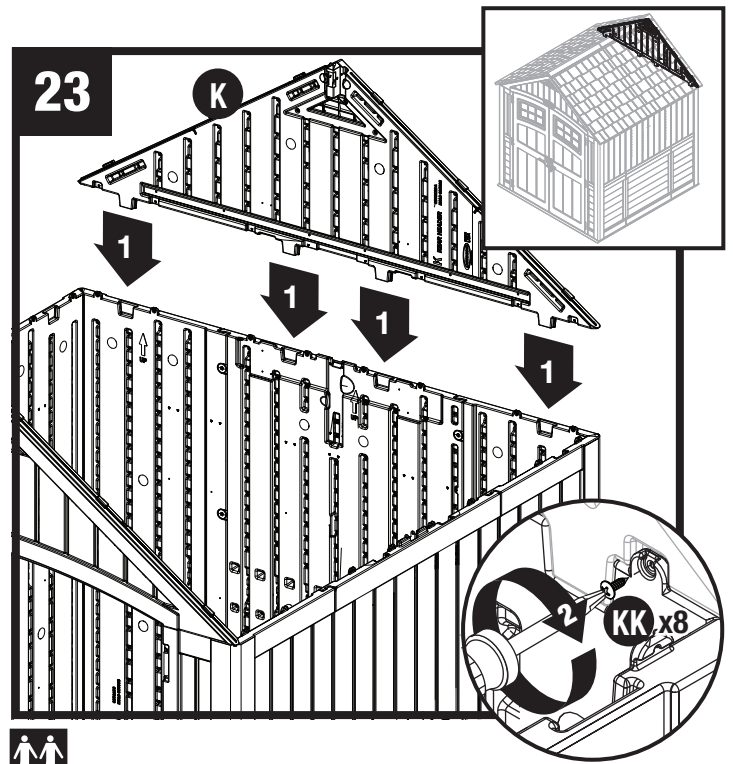

Place rear header (K) over back walls and fit four protruding support legs into pockets molded in back walls. Secure rear header using eight screws (KK).

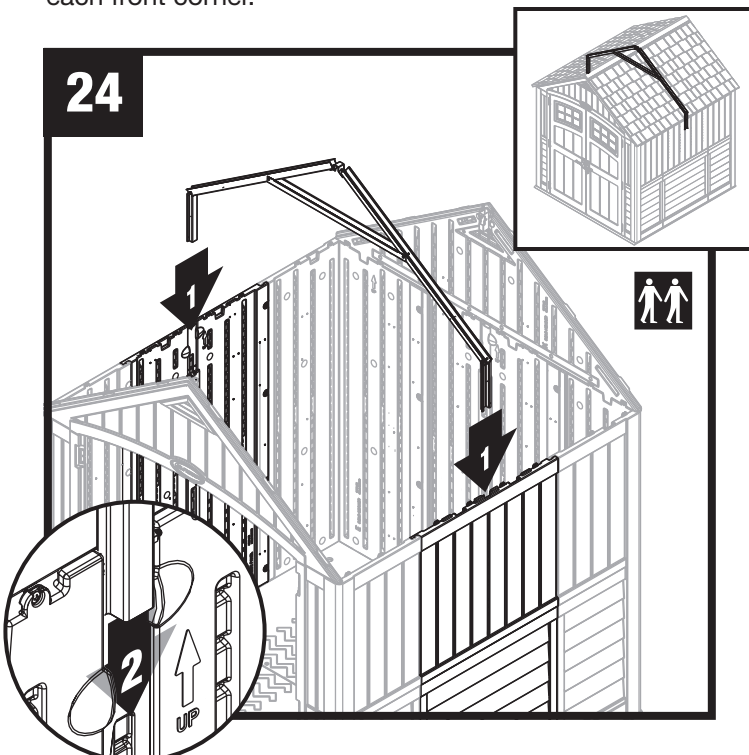

Slide truss assembly into place.

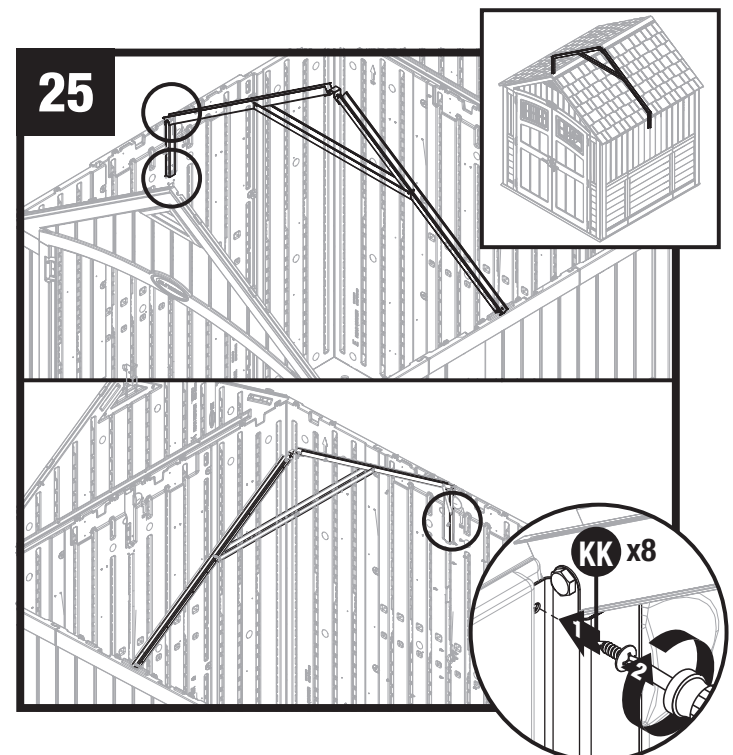

Secure with four screws (KK) in each side adaptor bracket

Shed Assembly/Headers and Truss (continued)

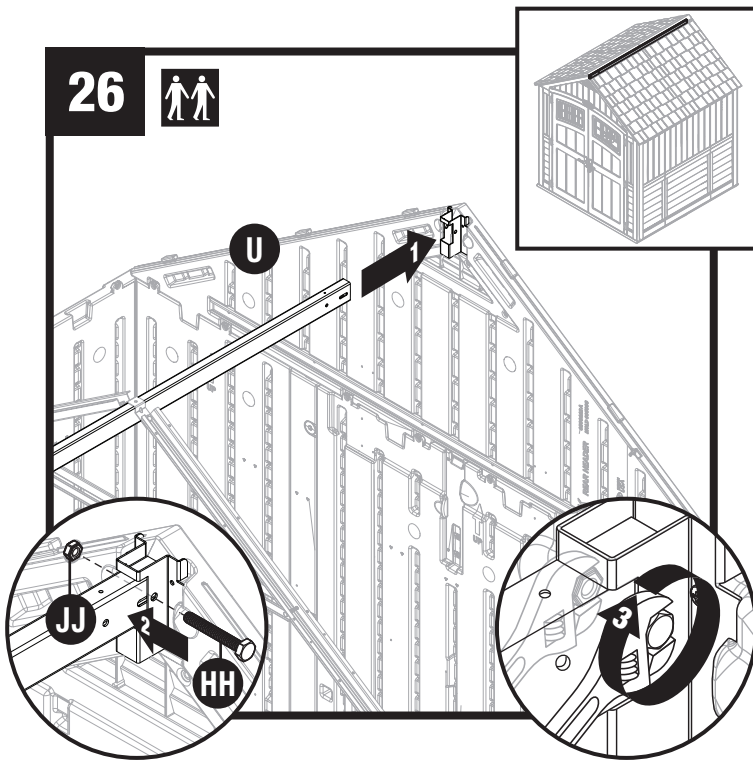

Raise ridge beam (U) up and into rear roof ridge beam bracket. Secure with one 2" hex head cap screw (HH) and one nut (JJ).

Note: Alignment of ridge beam to bracket may require header panels to be pushed inwards or outwards slightly as ridge beam is slid into place.

CAUTION! Part (U) orientation is critical, see picture.

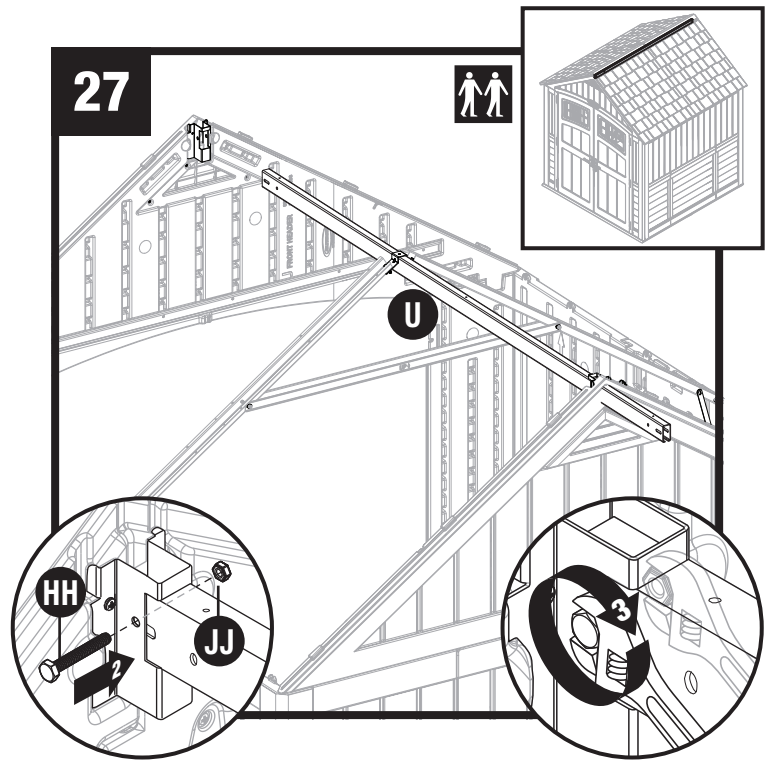

Slide ridge beam (U) into front roof ridge beam bracket. Secure with one 2" hex head cap screw (HH) and one nut (JJ).

Note: Alignment of ridge beam to bracket may require header panels to be pushed inwards or outwards slightly as ridge beam is slid into place.

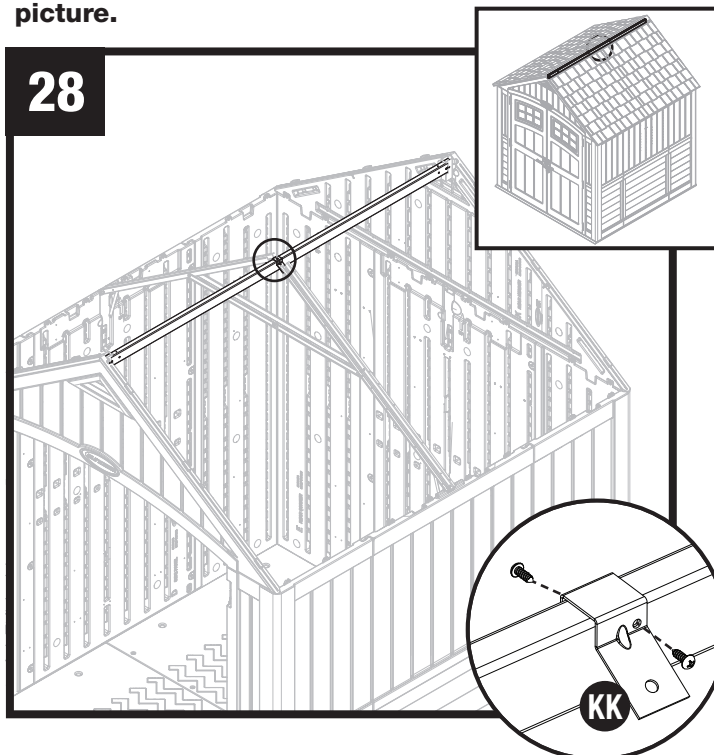

Attach the roof truss assembly to the ridge beam with two screws (KK).

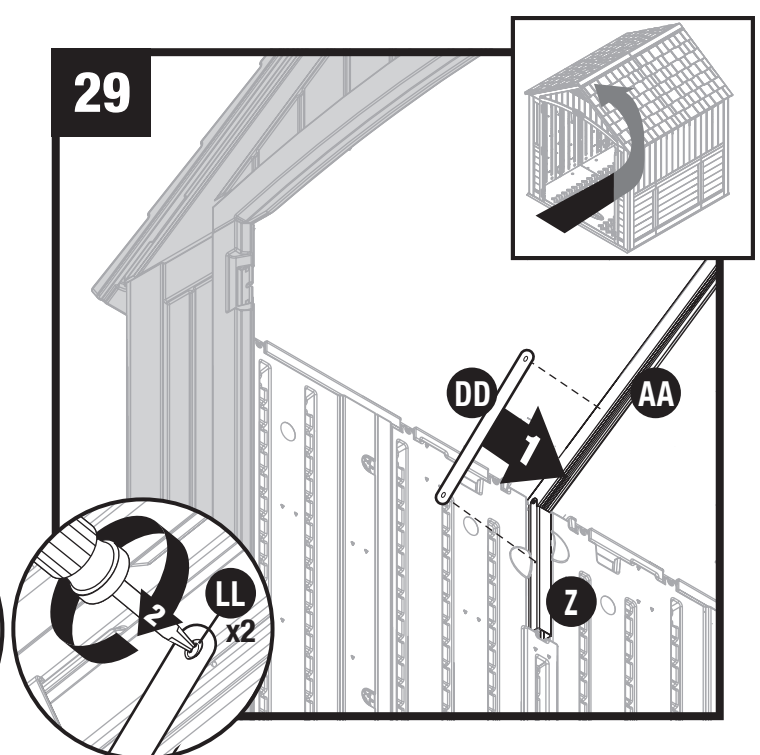

Attach truss strap (DD) to left truss tie down (Z) and truss leg (AA). Secure with two screws (LL).

Repeat for right side of truss.

Shed Assembly/Roof

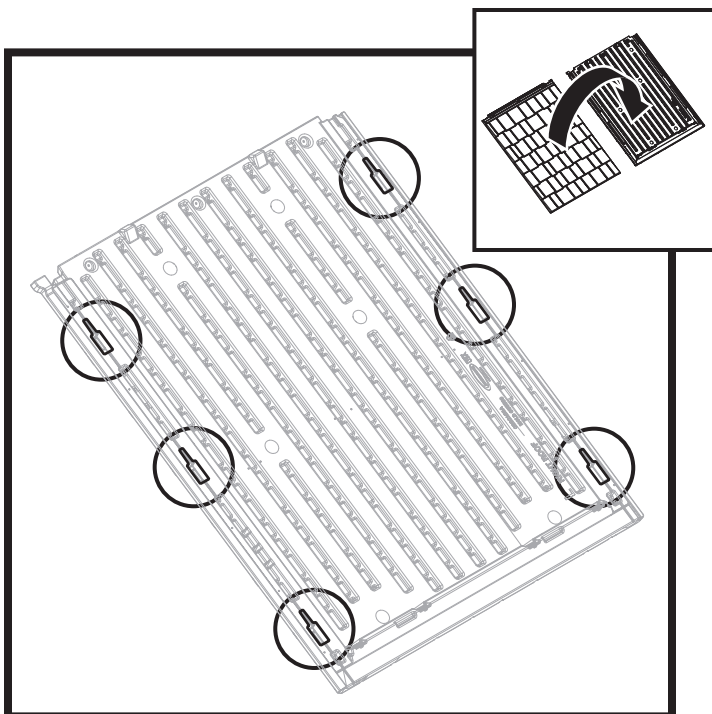

Before proceeding, locate and identify channels on interior side of right roof (L) and left roof (M). Locate three underside tabs contained within each channel.

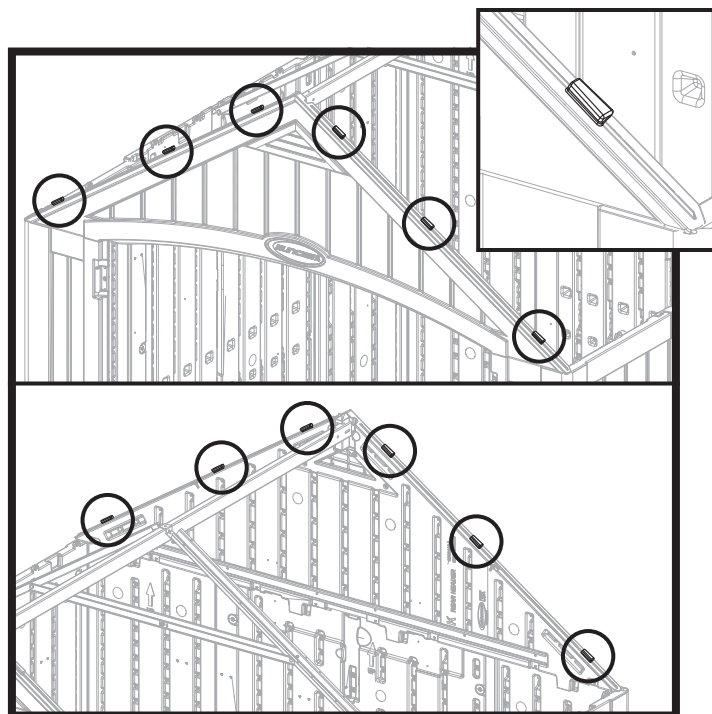

Before proceeding, locate and identify six front header tabs and six rear header tabs.

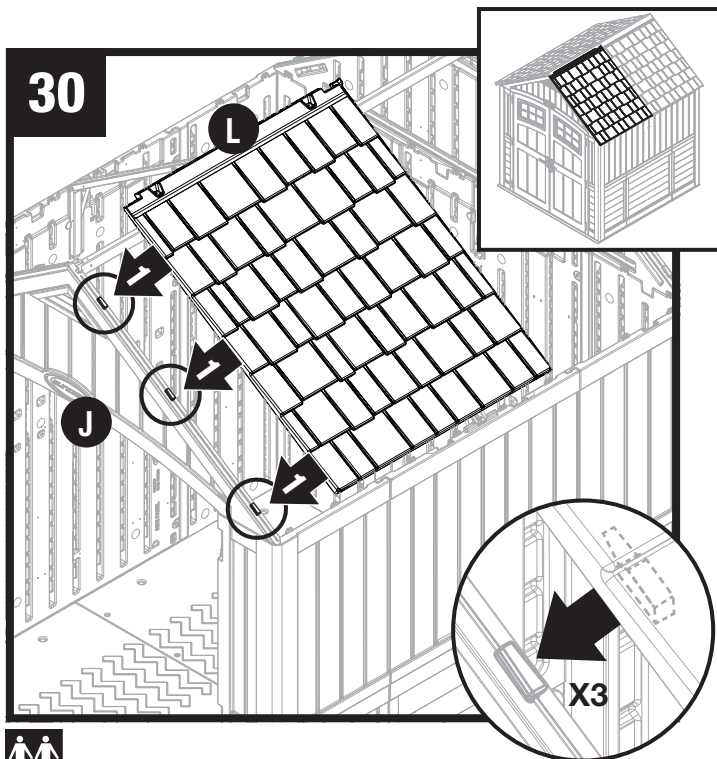

Lay right roof (L) directly over three tabs on right side of front header (J). With right roof channel seated over/on header tabs, check alignment in all three spots.

Shed Assembly/Roof (continued)

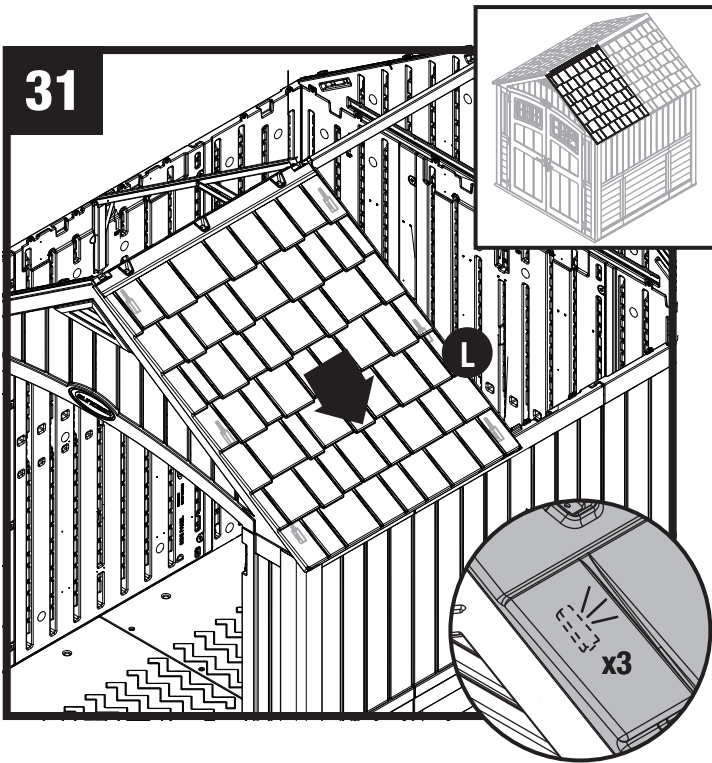

Slide right roof (L) down towards the outside of shed.
You will hear a "snap" when engaged.

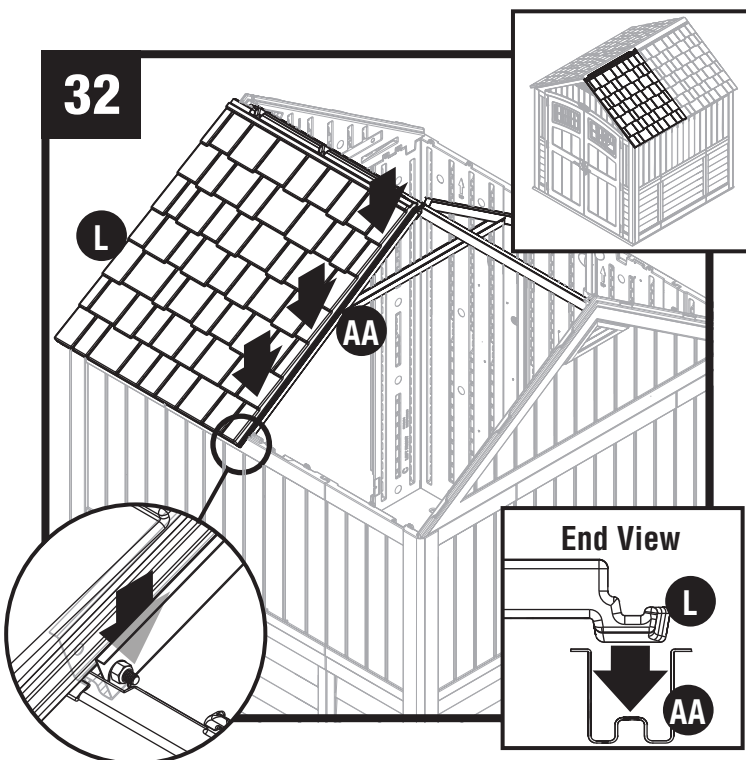

Press edge of right roof (L) into channel on truss leg (AA).

Shed Assembly/Roof (continued)

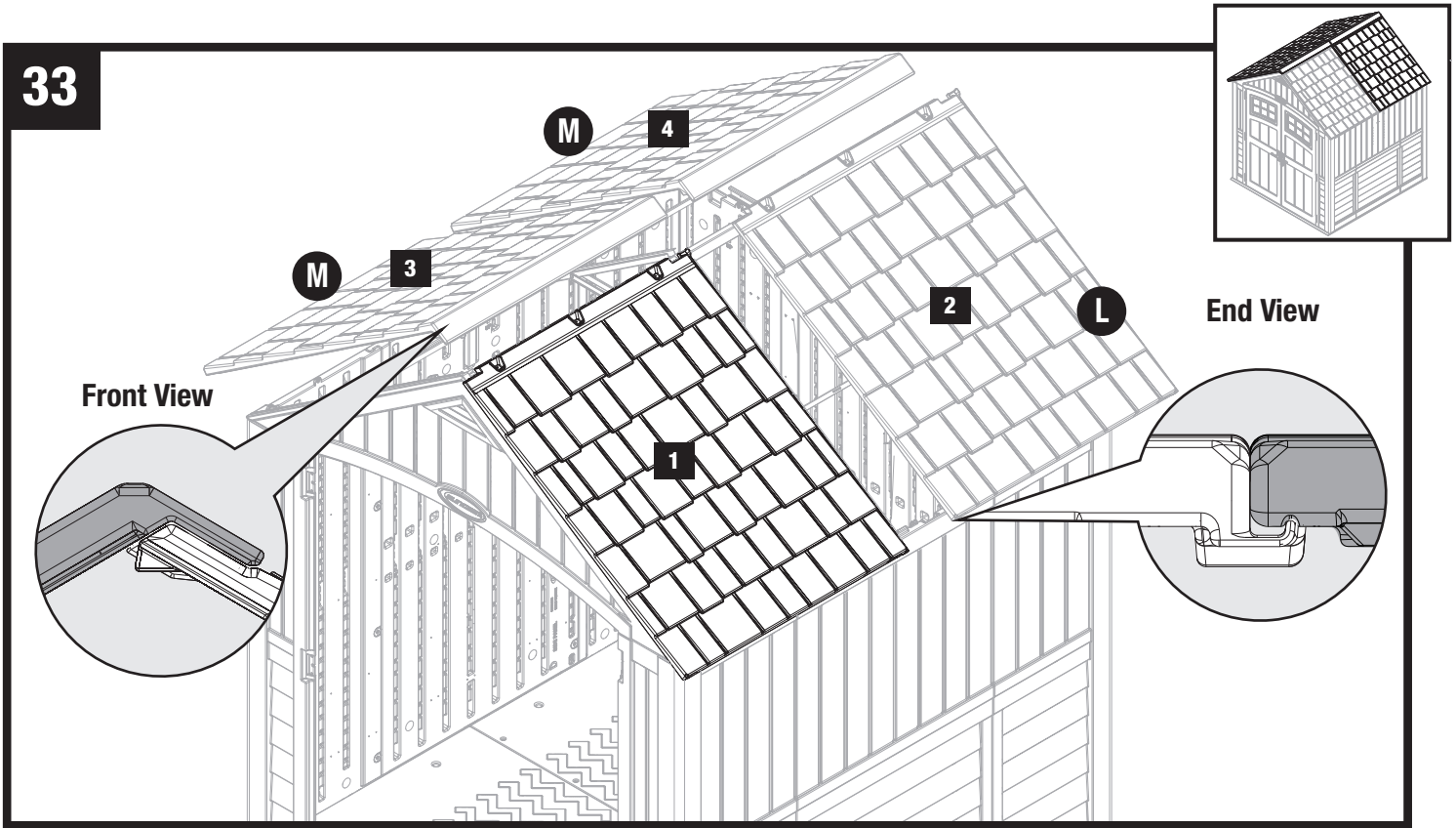

Repeat steps 30-32 for remaining roof panels. Install panels in the order shown.

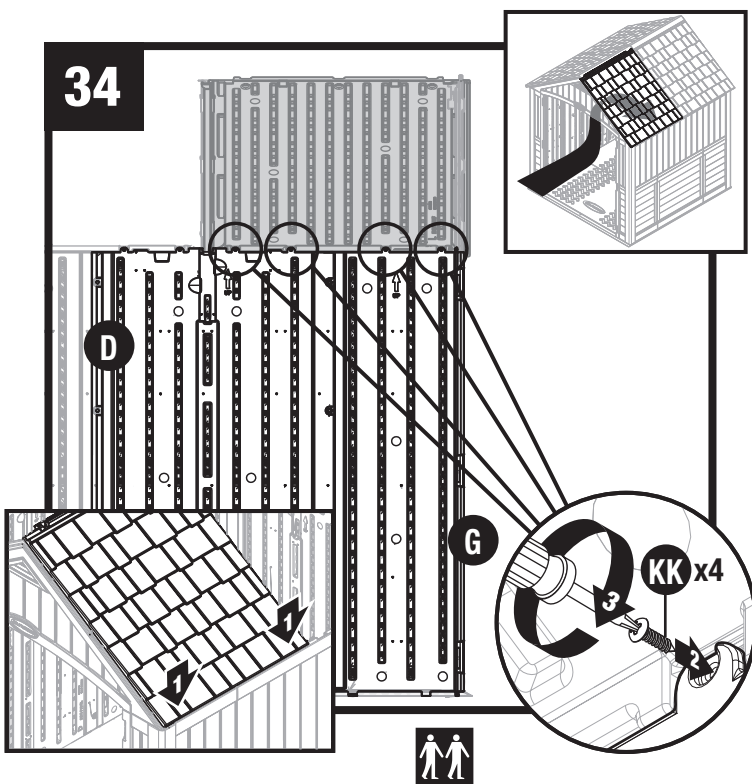

Pull down each lower corner of roof from outside. From inside shed, attach tabs on panel (D) and right front (G) corner to roof panel with four screws (KK).

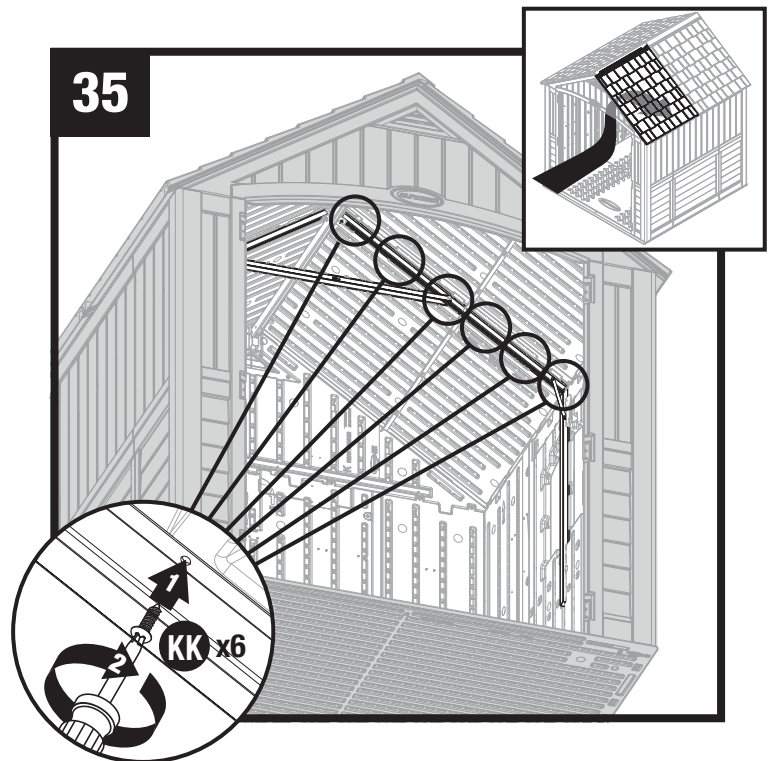

Secure roof to truss using six screws (KK). Each screw will attach at a corresponding screw boss on the roof.

Shed Assembly/Roof (continued)

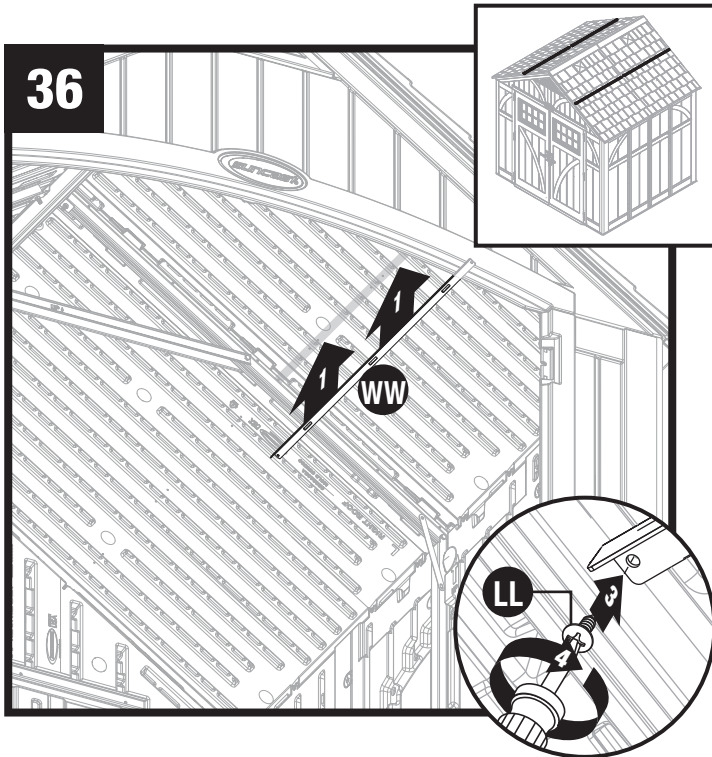

Raise roof support (WW) into position against roof. Slide roof support (WW) into front header. Secure roof support (WW) to underside of truss leg with one screw (LL).

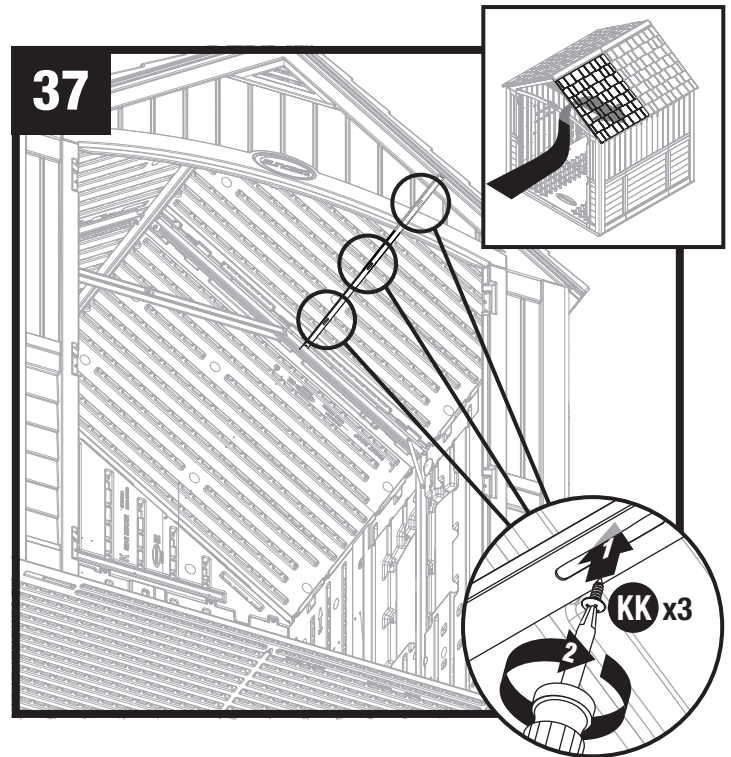

Secure roof support (WW) to roof using three screws (KK).

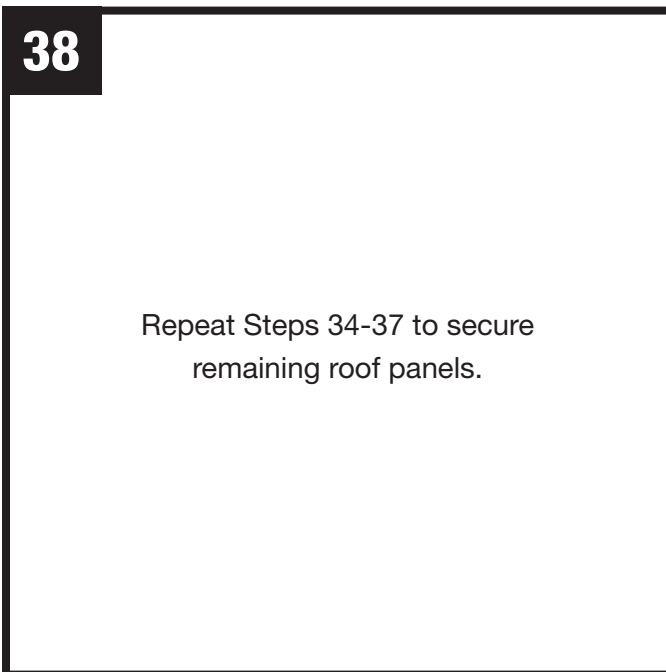

Repeat Steps 34-37 to secure remaining roof panels.

Shed Assembly/Roof (continued)

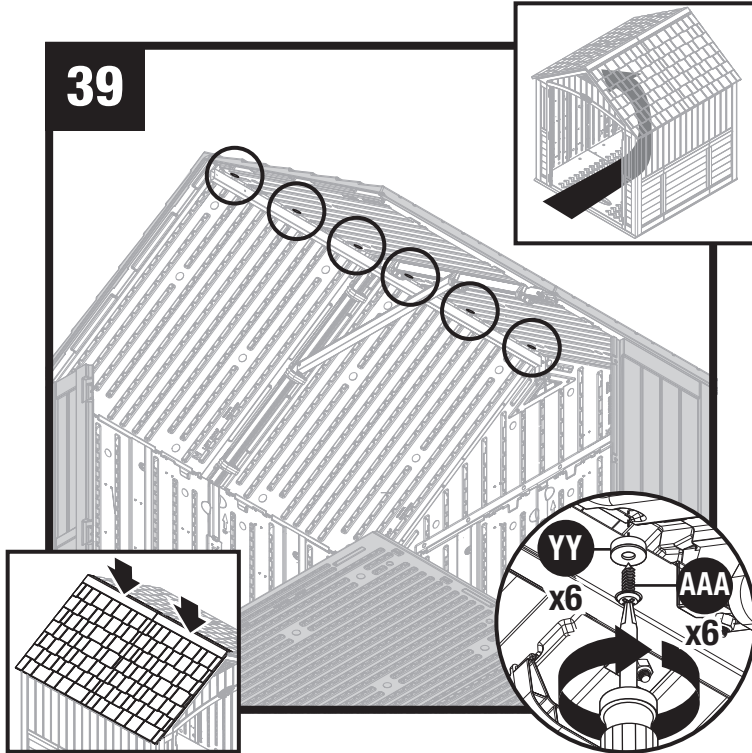

Push down the roof from outside. From inside shed, secure roof panels together along ridge of roof using six rubber washers (YY) and six sealing screws (AAA).

Note: For clarity, illustration is shown with front header, right front corner, and window panel removed.



Shed Assembly/Doors

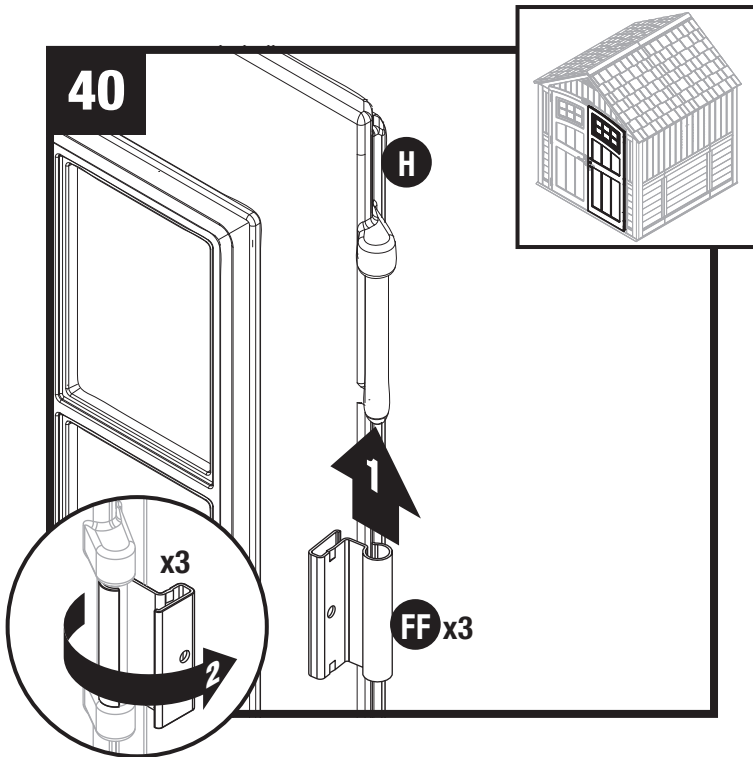

Stand right door (H) upright with three hinge mounts facing right. Slide one metal hinge plate (FF) up onto each hinge mount. Rotate hinge plates to outside of door. Snap metal hinge plate into place by pushing towards door.

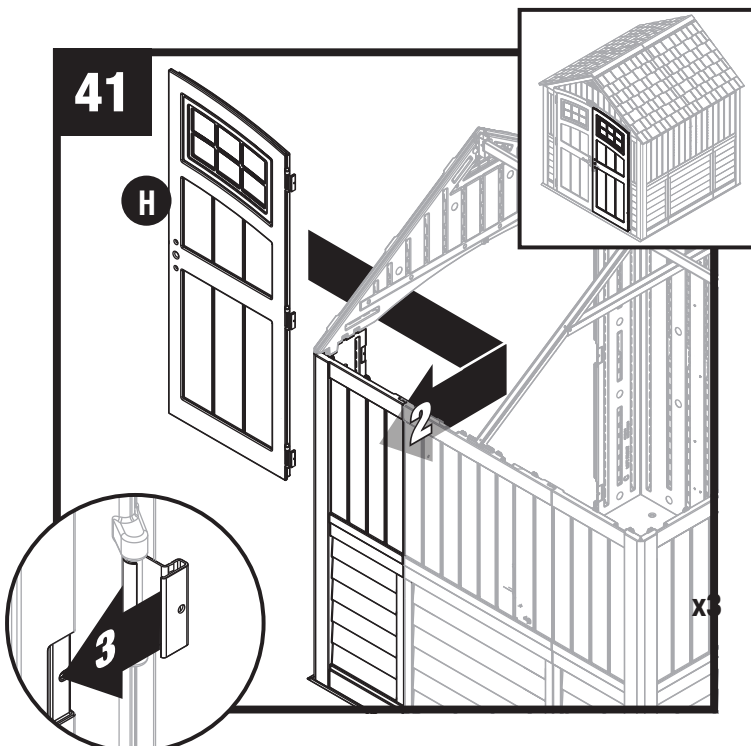

Rotate metal hinge plates to open position. Slide one metal hinge plate over each hinge receptacle on inside of right front panel.

Note: For clarity, illustration is shown with roof removed.



Shed Assembly/Doors (continued)

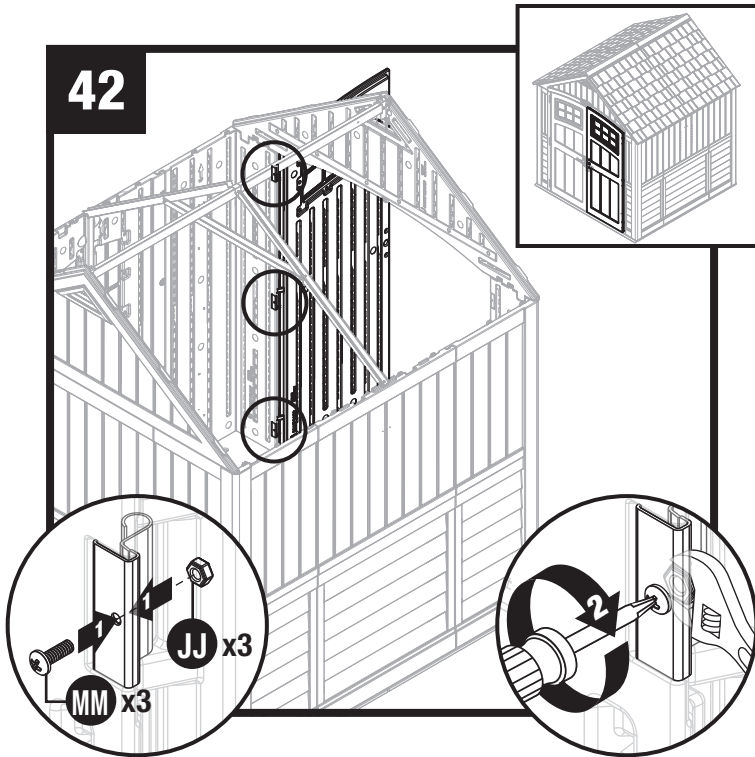

Secure each metal hinge plate with one screw (MM) and one nut (JJ).

Repeat Steps 40-42 for left door (l).

Note: For clarity, illustration is shown with roof removed.

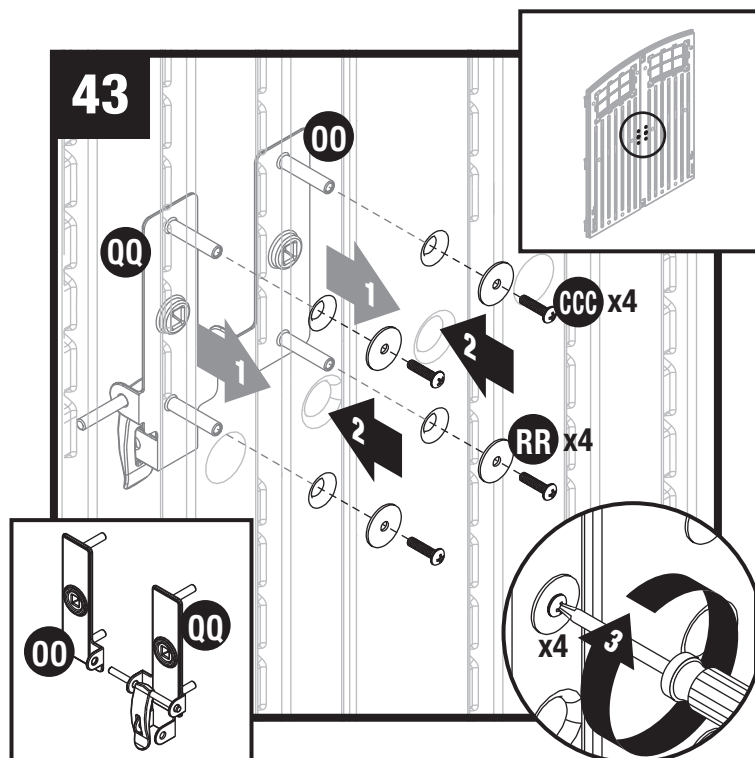

Insert screw stems, on left and right handle plates (OO) and (QQ), through the pre-drilled holes in doors. While holding plates in place on exterior of door, secure each with two washers (RR) and two machine screws (CCC).

Shed Assembly/Doors (continued)

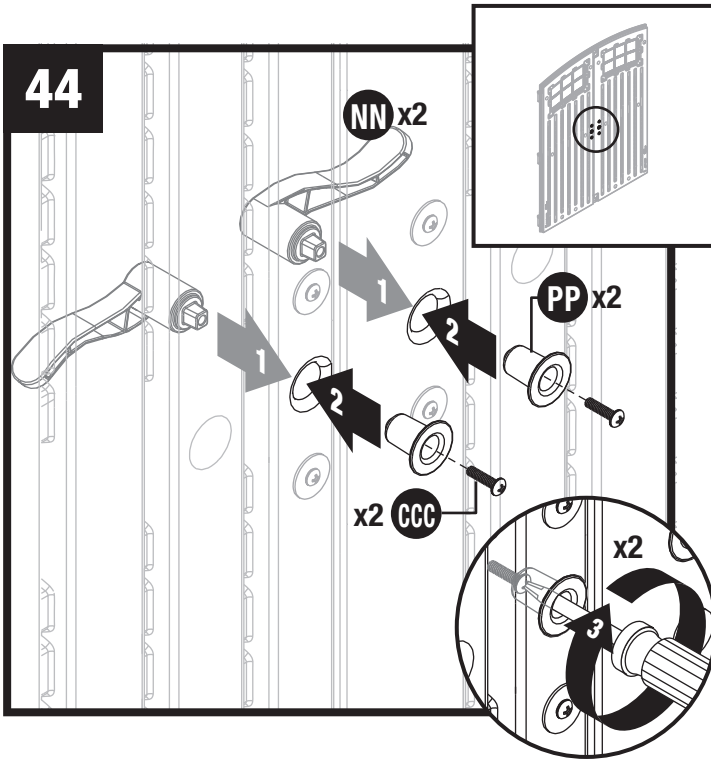

From the outside of doors, insert door handles (NN) through handle plate holes. On inside of doors, place spacers (PP) on each door handle, and secure each with one machine screw (CCC).

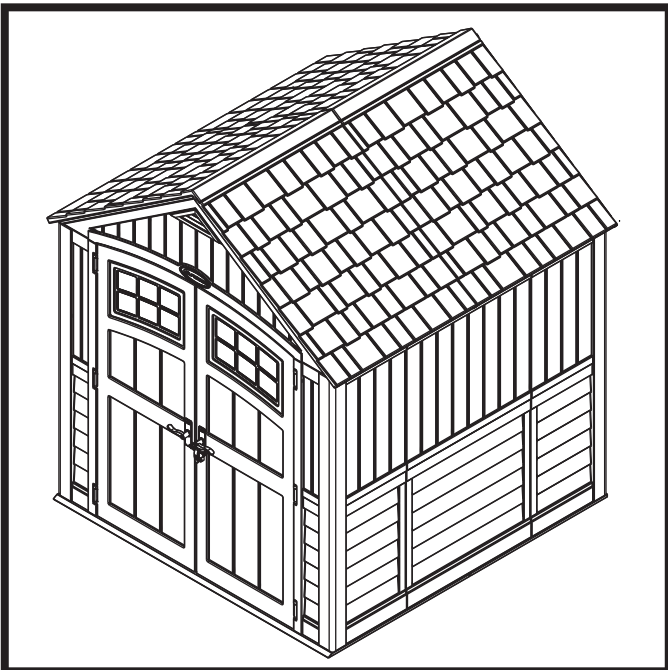

Complete.

Warranty

SUNCAST® Building, Shed and Gazebo Ten Year Limited Warranty

Your SUNCAST® Building, Shed or Gazebo has a TEN YEAR LIMITED WARRANTY against product failure resulting from defects in manufacturing or materials. The warranty period starts on the delivery date. Incidental and consequential damages are not covered.

Warranty Claims

To file a warranty claim contact the manufacturer, SUNCAST® CORPORATION, 701 North Kirk Road, Batavia, Illinois, 60510. Call toll free (800) 846-2345 or visit www.Suncast.com.

SUNCAST® will repair or replace only the parts that failed under the terms of the warranty. In some cases, the replacement parts may not be identical, but they shall be of equal or greater performance than the original part.

We may require proof of purchase. Proof of purchase may be the original dated store receipt. We may require evidence of the failure. Evidence of failure may include photographs or returning failed components to SUNCAST.

WARRANTY LIMITATIONS

THIS WARRANTY COVERS ONLY DEFECTS THAT AFFECT THE FORM, FIT OR FUNCTION OF THE UNIT. It excludes natural aging of the unit, discoloration, ordinary wear and tear, ordinary weathering, sunlight fading, or rust. It excludes staining caused by mold, mildew or tree sap and damage caused by animals including insects, vermin or household pets. The warranty does not cover damage caused by Acts of Nature including but not limited to: wind in excess of 65 mph; tornado; hurricane; microburst; hail; flood; blizzard; extreme heat; pollution or fire events. For all storm and windy conditions, the doors must be closed and latched with the latching devices supplied with the shed to prevent damage. Left and right doors may have different latches, and both must be engaged. Latching devices vary by model. The warranty does not cover damage caused by Sun energy reflected from "Low-E" windows or other reflective materials. The user is responsible for protecting the product from damage in this situation.

The following actions void the warranty: improper assembly; assembly on a foundation other than as described in the assembly instructions; use above intended and reasonable capacity; misuse; abuse; failure to perform ordinary maintenance; failure to remove snow over 8 inches deep; modification; cleaning with abrasive tools, exposing the unit to heat sources and vandalism. Painting, sandblasting, cleaning with harsh chemicals not recommended for plastics voids the warranty on resin components. Modification of the original product voids all warranties. Suncast assumes no liability for any modified product or consequences resulting from failure of a modified product. Damage due to moving, transporting, or relocating the product voids the warranty. Disassembly of this unit for reasons other than authorized repair voids the warranty.

Suncast is not responsible for: loss of use of the unit; labor for repair; inspection fees or disposal costs.

SUNCAST® reserves the right to reimburse the owner the purchase price of the unit on a STRAIGHT LINE DEPRECIATED BASIS FOR THE LENGTH OF THE WARRANTY IN LIEU OF REPAIR OR REPLACEMENT. The Purchase Price does not include taxes, delivery charges, site preparation costs, permits, fees, assembly costs, or disposal costs.

THIS WARRANTY IS NONTRANSFERABLE. IT IS VALID FOR NORMAL HOUSEHOLD USE ONLY. THE WARRANTY IS VOIDED BY COMMERCIAL OR INDUSTRIAL USE. IT EXCLUDES FLOOR MODELS, CLEARANCE AND OPEN BOX UNITS.

Notice

Suncast® does not represent that this unit will meet city, county, state, homeowner's association standards or zoning requirements. The owner is responsible for securing all permits and meeting other requirements needed for placement, construction and use.

THE MANUFACTURER'S LIABILITY HEREUNDER IS LIMITED SOLELY TO THE REPAIR OR REPLACEMENT OF THE DEFECTIVE PRODUCT OR PART AND THE MANUFACTURER SHALL IN NO EVENT BE LIABLE FOR ANY INCIDENTAL OR CONSEQUENTIAL DAMAGES WHICH MAY RESULT FROM ANY DEFECT IN MATERIAL OR WORKMANSHIP OR FROM THE BREACH OF ANY EXPRESS OR IMPLIED WARRANTY.

This warranty gives you specific legal rights, and you may also have other rights which vary from state to state. Some states do not allow the exclusion or limitation of incidental or consequential damages; the limitation or exclusion may not apply to you.

