



PRODUCT REGISTRATION:

MAKE SURE TO REGISTER YOUR PURCHASE AT
<http://allensportsusa.com/about/product-registration>
TO QUALIFY FOR PRODUCT WARRANTY AND TO RECEIVE
IMPORTANT PRODUCT NOTIFICATIONS

MODEL XR200 2-BIKE CARRIER



Owner's Manual should be kept for future reference

1. Completely read and understand Owner's Manual before assembling or operating this product.
2. This product should be assembled by an adult.

! WARNING:

Bicycles or rack falling in road can cause serious accidents resulting in bodily injury – do not use rack on any vehicle on which it can't be properly mounted as described in this instruction sheet.

- Rack should only be used on vehicles with Class II 1 1/4", or Class III or IV 2" receiver hitches.
- Never used on a trailer, fifth wheel, or RV, or the front of a vehicle.
- Only carry bicycles with 20" to 29" diameter wheels, and tires up to 3" wide.
- Only carry bicycles with a wheelbase of min. 35" to max. 48".
- Max. allowable bicycle weight: 35 LB; Max. rack capacity: 70 LB.
- Never carry tricycles, mopeds, recumbents, or electric bicycles. Car tail lights must remain visible.
- Bikes must be securely tied to rack using bike tie-downs and additional straps as needed.
- Check periodically during use that all bolts and knobs are tight and that bicycles are secure.
- Drive conservatively, especially over bumps. Never use off road.
- Never use rack if any parts are damaged or worn. Contact R. A. Allen Company for replacement parts.

! CAUTION:

Use XR200 only in accordance with local motor vehicle and traffic regulations

- INSTALL RACK AND LOAD BICYCLES ONLY AT A SAFE DISTANCE AWAY FROM MOVING TRAFFIC.
- MAKE SURE THAT ALL OF RACK AND BICYCLES ARE CARRIED AT A SAFE DISTANCE FROM ROAD AND HOT EXHAUST.
- ONLY OPERATE VEHICLE WITH RACK IN AN UPRIGHT, LOCKED POSITION.
- BICYCLES SHOULD NEVER EXTEND BEYOND THE SIDE OF VEHICLE DURING TRANSPORT.
- REMOVE RACK FROM CAR WHEN NOT IN USE.



PARTS LIST

QUANTITY DESCRIPTION

HARDWARE KIT INCLUDING

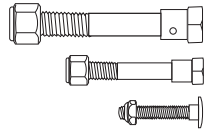

1	1/2" No Wobble Bolt & Nut
1	3/8" No Wobble Bolt & Nut
10	1.75" Carriage Bolts and Nylon Insert Nuts

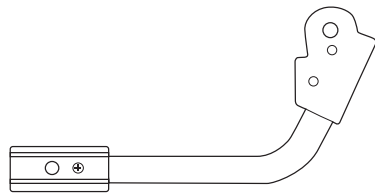

1	Hitch Insert & Filler Plate
---	-----------------------------

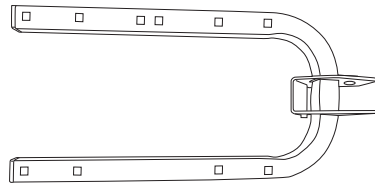

1	U FRAME
---	---------

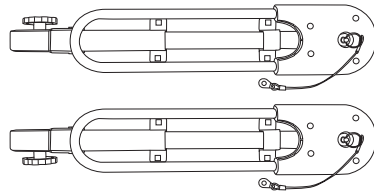

2	Folding Wheel Trays
---	---------------------

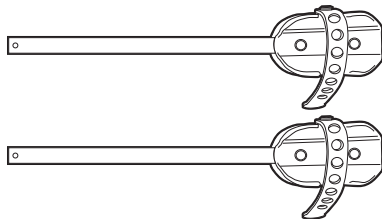

2	Sliding Wheel Trays
---	---------------------

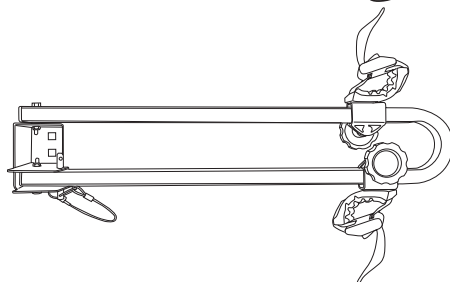

1	Upright Support Arm
---	---------------------



ASSEMBLY INSTRUCTION

Tools Required:

2—adjustable wrenches, or 2—3/4" wrenches, 1—1/2" wrench, and 2—9/16" wrenches (for 1 1/4" hitch installation)

NOTE: The XR200 is easiest to assemble with the rack hitch insert installed on the vehicle. The instructions below are based on this assembly method.

STEP 1: INSTALLING HITCH INSERT ONTO VEHICLE

NOTE: XR200 should only be used with a 2" receiver hitches or Class II 1 1/4" receiver hitches installed on automobiles. NEVER use this rack on a trailer, fifth wheel, or RV, or the front of a vehicle.

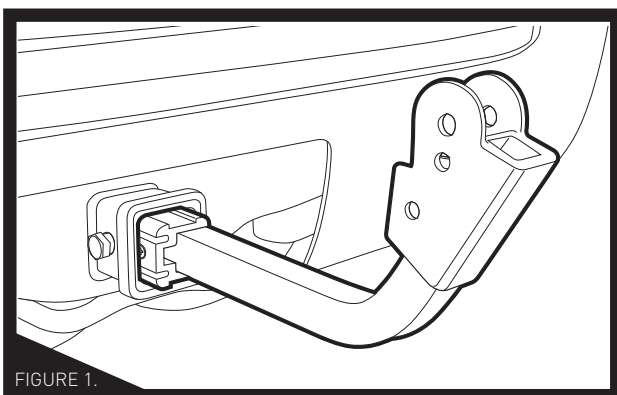

FIGURE 1.

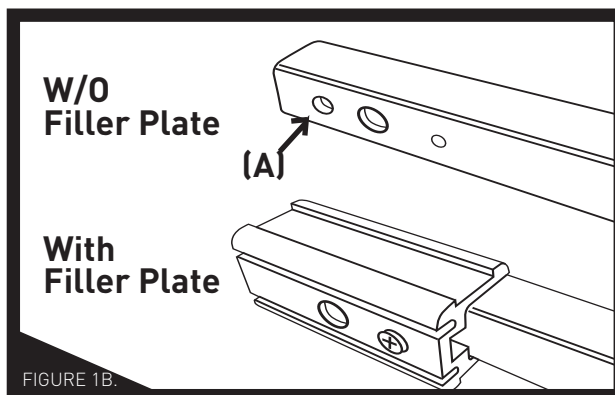

FIGURE 1B.

ADJUSTING FOR HITCH SIZE:

Filler Plate and retaining screw should be installed/ removed depending on the size of the receiver hitch in which the rack is being used.

For 2" Receiver Hitch: Filler Plate should be installed on the hitch insert with the included retaining screw.

For 1 1/4" Receiver Hitch: Remove Filler Plate and retaining screw and set aside (save for future use).

NO WOBBLE BOLT:

Properly installing the No-Wobble Bolt is critical for proper performance of the rack in your receiver hitch.

FOR 2" HITCHES: Install the rack with the 1/2" (larger) No Wobble Bolt included with the product.

FOR 1 1/4" HITCHES: Install the rack with the 3/8" (smaller) No Wobble Bolt included with the product.



ASSEMBLY INSTRUCTION (CONT.)

TIGHTENING HITCH INSERT ONTO YOUR VEHICLE:

- Insert hitch insert of the rack into the receiver hitch on your vehicle. Line up hole in the hitch insert with the hole on your receiver hitch.
- Note on lining up the correct hole on the hitch insert: On the 2" hitch there is only one hole to line up, but on the 1 1/4" size hitch there are two possible holes on the hitch insert. For the rack to be properly tightened in the hitch it is important that you line up the middle hole on the hitch insert with the hole on your receiver hitch. **(Shown a hole "A" in the Drawing Figure 1B)** When lined up, the first hole on the rack's hitch insert should be undersized relative to the hole on the receiver hitch – this will allow the No Wobble Bolt to properly tighten the rack in the hitch.
- Once the holes are lined up, insert the appropriate No Wobble Bolt into the hole, making sure that shoulder of the bolt comes up against the wall of the rack's hitch insert inside of the receiver hitch.
- Tighten the bolt firmly using two 3/4" or 9/16" wrenches (depending on the hitch size). There should not be any side to side movement of the rack inside of the hitch when this is done.

STEP 2: ATTACHING U FRAME TO HITCH INSERT

Line up the larger (1/2") hole on the U Frame bracket with the larger (1/2") hole on the Hitch Insert and pass the 1/2" Bolt through the hole **(STEP 2A)**. Slide the metal tether for the wire lanyard over the bolt **(STEP 2B)** then secure the bolt by fully tightening the 1/2" Nut onto the bolt. Make sure that the threads of the bolt fully pass through the nylon washer on the inside of the nut to ensure that the nut and bolt are properly tightened. **Note:** Nut and bolt should be tightened so that the nut is secure, but so that the U Frame can rotate freely relative to the Hitch Insert.

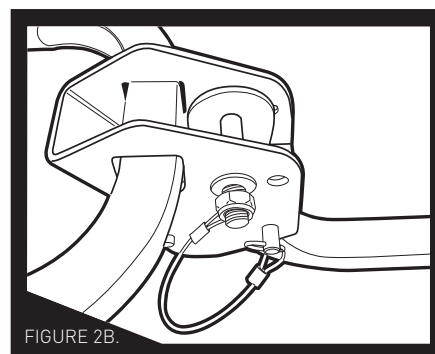
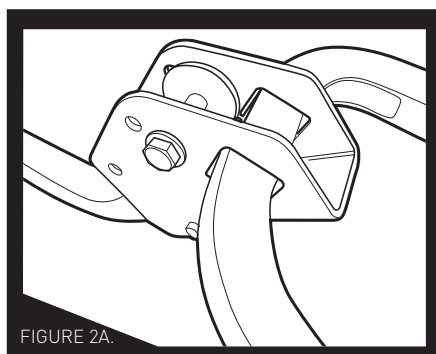
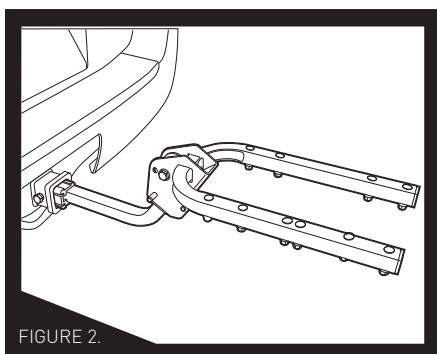

STEP 3: ATTACHING AND ASSEMBLING WHEEL TRAYS, AND UPRIGHT SUPPORT ARM TO U FRAME

NOTE:

Folding Wheel Trays are not identical and for easiest loading of bicycles the correct tray should be installed in the correct location.



ASSEMBLY INSTRUCTION (CONT.)

STEP 3A: First wheel tray (The one without the Allen Label) should be installed with folding wheel tray toward the passenger side of vehicle and red tightening knob facing the rear of the carrier. Line up the holes on the wheel tray and secure to U Frame by fully tightening four of the 1.75" Black carriage bolts and nuts. **Note:** use the outside bolt on the passenger side to secure the metal tether for the wire lanyard (**STEP 3A-1**).

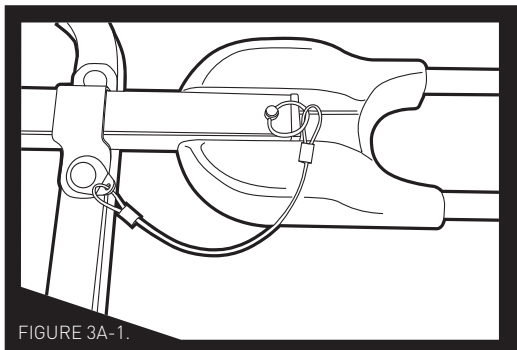

FIGURE 3A-1.

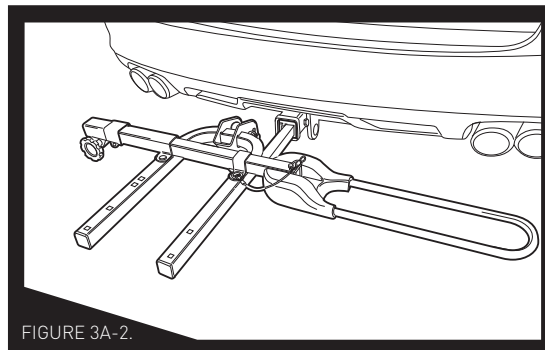

FIGURE 3A-2.

STEP 3B: **Installing Sliding Wheel Tray.**

1. Loosen red tightening knob (**Fig. 3B - "A"**).
2. Making sure that the plastic wheel tray is facing up, depress silver button on the underside of the square tube and insert Sliding Wheel Tray into open end of installed wheel tray. The silver button will have to be pushed in twice more so that the plastic wheel tray slides freely.

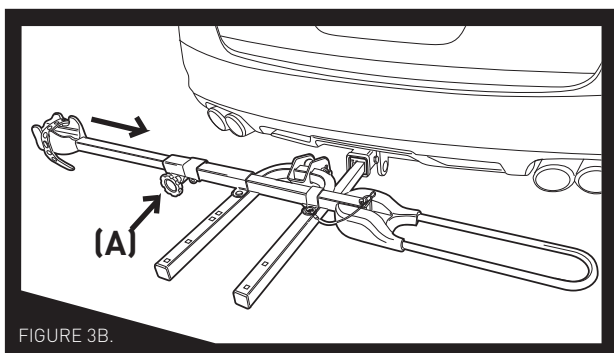

FIGURE 3B.

STEP 3C: **Installing and assembling second wheel tray:**

Second wheel tray should be installed with folding wheel tray toward the driver side of vehicle and red tightening knob facing the rear of the carrier. Line up the holes on the wheel tray and secure to U Frame by fully tightening four of the 1.75" Black carriage bolts and nuts. **Note:** use the outside bolt on the driver side to secure the metal tether for the wire lanyard. To install sliding wheel tray, repeat instructions from Step 3B above.

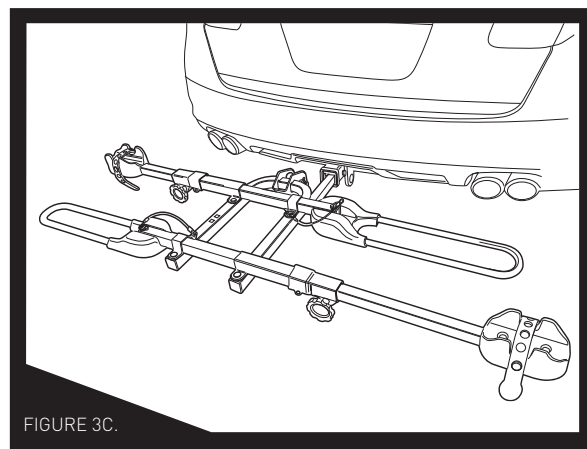

FIGURE 3C.



ASSEMBLY INSTRUCTION (CONT.)

STEP 3D: **Installing Upright Support Arm**

Line up two holes on Upright Support Arm base with the corresponding holes on the U Frame, and fully tighten in place using two of the 1.75" carriage bolts and nuts

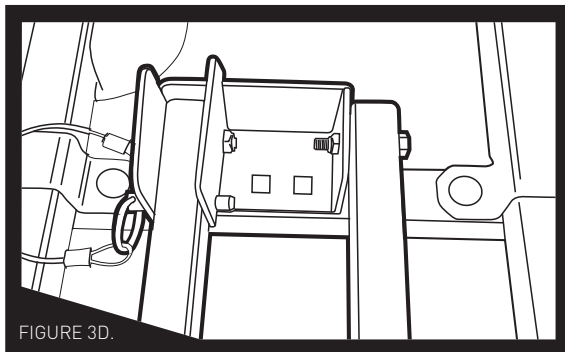

FOLDING RACK AGAINST VEHICLE WHEN NOT IN USE

FOLD WHEEL TRAYS (Fig. 4A - "A")

- Remove pin
- Rotate in Wheel Tray
- Reinstall pin

FOLD DOWN UPRIGHT SUPPORT ARM

- Remove support pin
- Fold down arm (Fig. 4A - "B")
- Reinstall pin

FOLD UP RACK (Fig. 4B)

- Remove support pin
- Fold rack up to vertical
- Reinstall pin

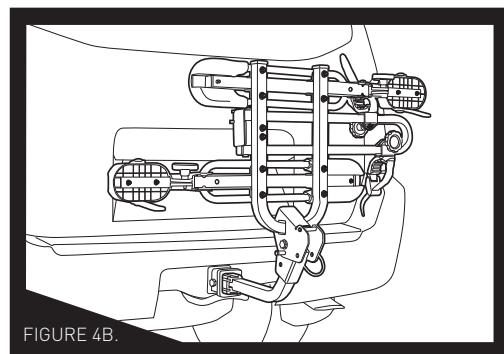
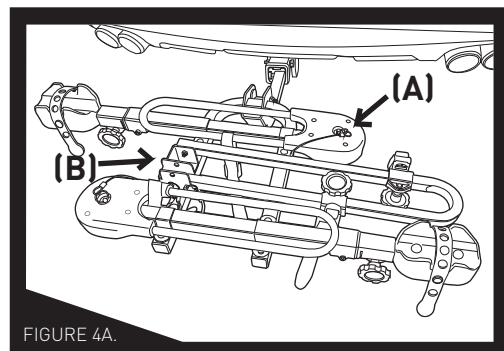



INSTALLING BICYCLES ONTO XR200

Install first bicycle in position closest to vehicle first

STEP 1: Fold out metal wheel trays, making sure that pins are in place and place the Upright Support Arm in the up position by rotating this up and properly securing in place with the release pin ("A").

STEP 2: Adjust location of plastic wheel cup to match the wheelbase of bicycle to be installed, making sure to properly tighten the red knob when the proper wheel cup location is determined

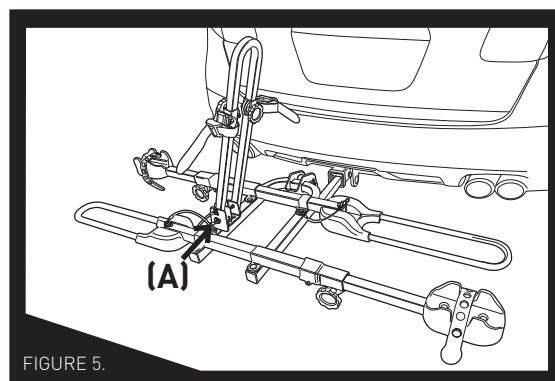

FIGURE 5.

STEP 3: Place the first bicycle with one wheel in metal wheel tray and other properly centered on plastic wheel cup. Secure wheel to Plastic Wheel Cup using the rubber tension strap (Fig. 5A). Other wheel should be fully secure to the metal wheel tray using the strap and buckle as shown in drawing below.

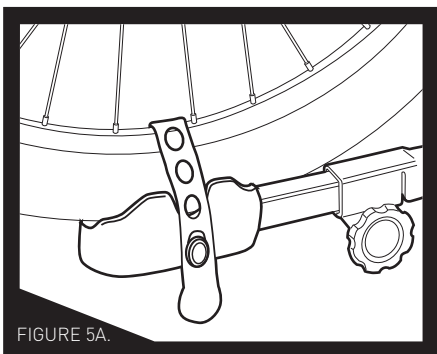

FIGURE 5A.

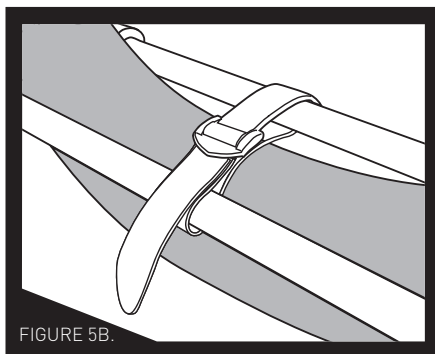

FIGURE 5B.

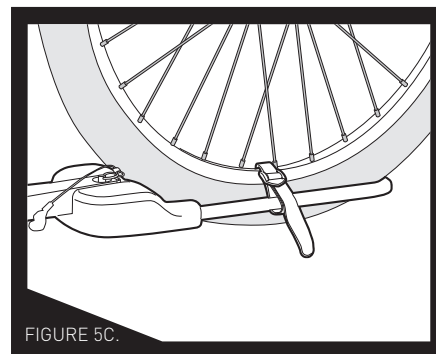

FIGURE 5C.

STEP 4: Adjust the location of the Frame Securing Strap so that it can be properly secured and tightened to the bicycle frame. Make sure that the red knob is properly tightened so hold Securing Strap Assembly in place on square tubing.

STEP 5: Secure bicycle in place with Frame Secure Strap by threading strap through the cam buckle and fully tightening around bicycle frame (Fig. 6A).

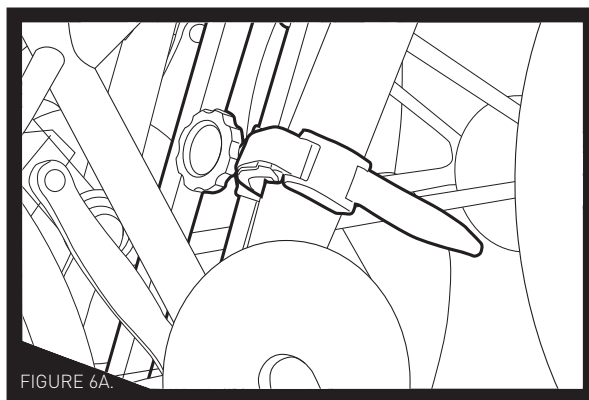
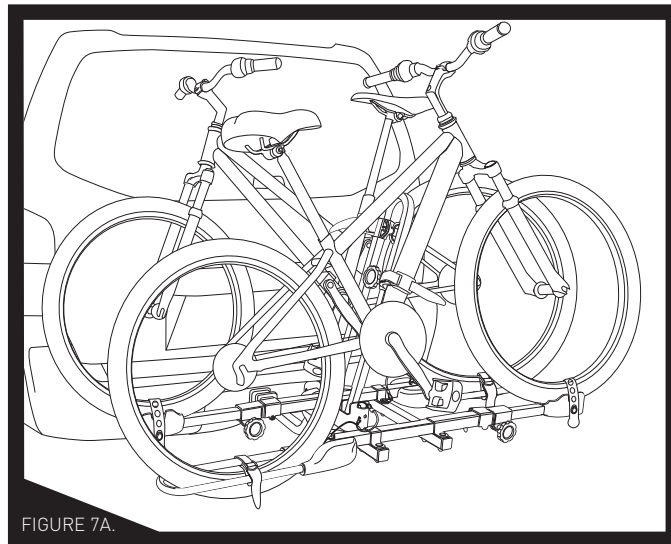
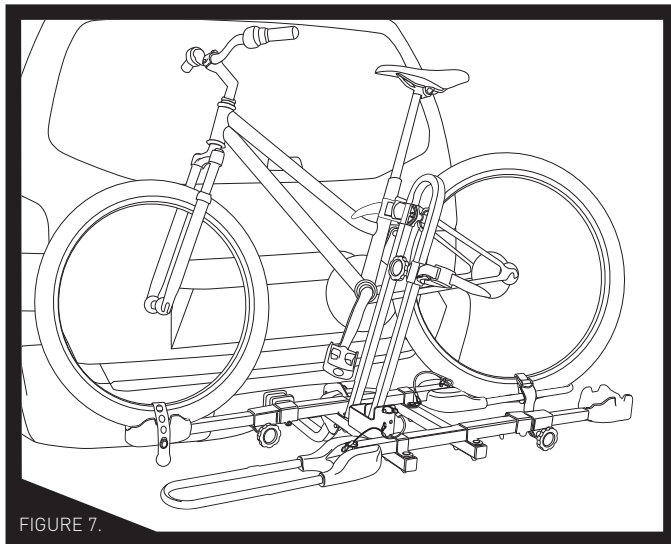

FIGURE 6A.



INSTALLING SECOND (OUTER) BICYCLE TO XR200

STEP 1: With the outside bicycle facing in the opposite direction of the inside bicycle, install the bicycle using the same methods as described for the first bicycle



FOR QUESTIONS REGARDING WARRANTY SERVICE, ASSEMBLY,
INSTALLATION, OR USE, PLEASE CONTACT

ALLEN SPORTS USA
(800) 722-5536 - CUSTOMERSERVICE@ALLENRACKS.COM

Please note that all returns and exchanges are subject to the return policy of the retailer where the product was originally purchased



ALLEN
SPORTS

R. A. ALLEN CO., INC. - 60 Thoreau St. #161 Concord, MA 01742, USA
www.allensportsusa.com

Product designed in USA, Made in Shanghai, China