



PRODUCT DESCRIPTION

5226 Series 26" Vanity Drawer

- Available in White (WHT) or Espresso (ESP) Finish
- Solid Wood Frame
- Modular Suite Component
- Satin Nickel Hardware
- Top Sold Separately

PRODUCT MEASUREMENTS

- Width: 26"
- Depth: 21"
- Height: 6.75"

RECOMMENDED ACCESSORIES

- 5221, 5222 or 5223 Vanities
- 1665 Stone Top
- 5228 Wall Cabinet
- 5224 Linen Tower
- 9707 or 9708 Mirrors
- 5230 Support Leg
- 5229 Vanity Stool

ROUGHING-IN DIMENSIONS

Please Note: All drawings contain the necessary measurements which are subject to standard industry tolerances. They are stated in inches and are non-binding. Exact measurements, in particular for customized installation scenarios, can only be taken from the finished product.

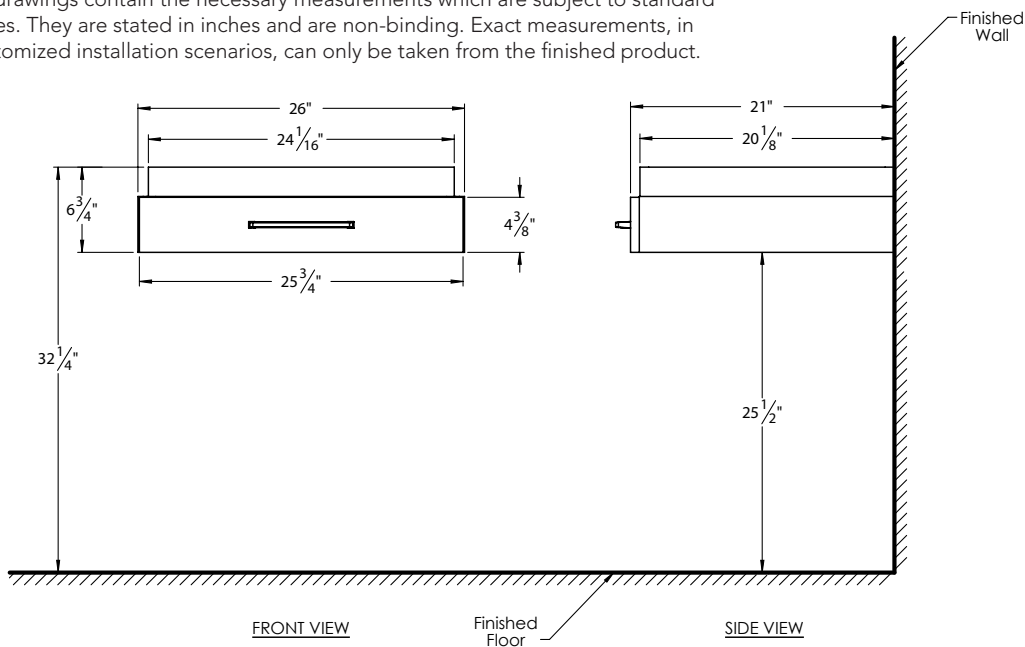
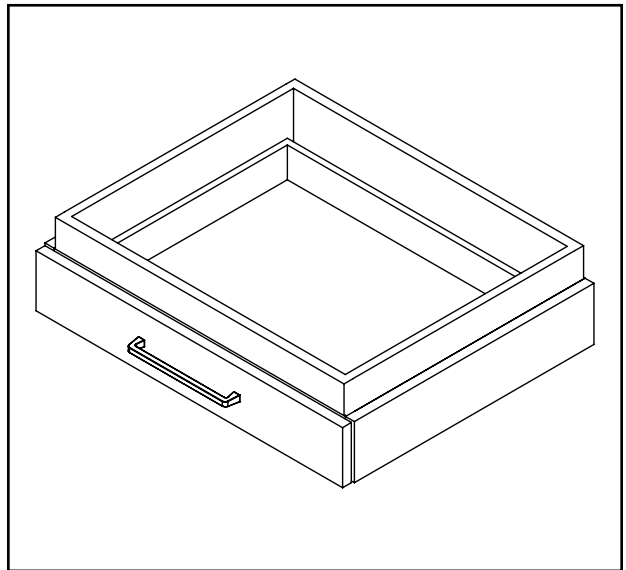

POSSIBLE MODULAR CONFIGURATIONS

Note: Requires Vanity and/or Support Leg For Installation

