



ST-GP7500DEB
GP-7500DEB

Owner's Manual

Don't work harder. Work smarter.



WARNING! To Reduce Risk of Injury, User Must Read and Understand Owner's Manual Prior to Use.



NOTE: Retain Original Sales Receipt as Proof of Purchase!

©2012 Smarter Tools, Inc. All Rights Reserved

7500W Generator Table of Contents

Introduction	04	Wattage Reference Guide	21
Safety Guidelines – Definitions	05	Your Power Needs.....	21
General Precautions	06	Inspection, Cleaning, and Maintenance	22
Carbon Monoxide	06	Changing Oil	22
Gasoline and Oil.....	06	Spark Plug	23
Propane.....	07	Air Filter.....	23
Hot Components	08	Spark Arrester (optional).....	23
Power Output	08	Cleaning.....	23
Work Area	08	Maintenance Schedule	23
Electrical Safety	09	Storage	24
Personal Safety.....	09	Transporting.....	24
General Use and Care	10	Specifications	24
Servicing.....	10	Parts Lists	25
Installation	11	Crankcase Assembly	26
Mechanical	11	Cylinder Head Assembly	27
Chemicals.....	12	Electromotion Starter Assembly	27
Noise	12	Valve Assembly	28
Extension Cords.....	12	Crankshaft Assembly.....	28
Controls and Features	13	Piston Assembly	29
Generator	13	Centrifugal Timing Implement Assembly	29
Control Panel	14	Inflame Assembly	29
Installation	15	Recoil Assembly	30
General Location.....	15	Engine Sprocket Cover.....	30
Wheel and Handle Kit Installation	16	Carburetor Unit	30
Support and Mounting.....	16	Air Cleaner Assembly	31
Grounding.....	16	Carburetor Assembly	31
Connect the Battery	17	Generator.....	32
Add Engine Oil	17	Gas Tank Assembly.....	32
Add Fuel.....	17	Control Panel Assembly	33
Operation	18	Muffler Assembly	33
Starting the Generator using Gasoline.....	18	Motor Shield Assembly	33
Connecting the Propane Fuel Supply	18	Frame Assembly.....	34
Starting the Generator using Propane	18	Exhalation system.....	34
Switching from Gasoline to Propane.....	19	LPG Regulator	35
Switching from Propane to Gasoline.....	18	Troubleshooting	36
Surge Protection	19	Warranty Identification	37
Capacity	19	Limited Warranty	38
Power Management.....	20		
Connecting Electrical Loads.....	20		
Stopping the Engine.....	20		



WARNING!

READ AND UNDERSTAND ALL SAFETY PRECAUTIONS IN THIS MANUAL BEFORE OPERATING. FAILURE TO COMPLY WITH INSTRUCTIONS IN THIS MANUAL COULD RESULT IN PERSONAL INJURY, PROPERTY DAMAGE, AND/ OR VOIDING OF YOUR WARRANTY. SMARTER TOOLS WILL NOT BE LIABLE FOR ANY DAMAGE BECAUSE OF FAILURE TO FOLLOW THESE INSTRUCTIONS.

7500W Generator

Introduction

Congratulations on your purchase of a Smarter Tools generator. Smarter Tools designs and builds generators to strict specifications. With proper use and maintenance, this generator will bring years of satisfying service.

Portable Power Generator

This unit is an electric start, gasoline engine driven, alternating current (AC) generator. It is designed to supply electrical power for lighting, appliances, tools and similar equipment.

This Booklet

Every effort has been made to ensure the accuracy and completeness of the information in this manual. We reserve the right to change, alter and/or improve the product and this document at any time without prior notice. For the most up to date information regarding your Smarter Tools product please visit us at

www.usesmartertools.com

Record the model and serial numbers as well as date and place of purchase for future reference. Have this information available when ordering parts and when making technical or warranty inquiries.

Smarter Tools Customer Service
1-804-798-8588
Model Number
GP-7500DEB
Serial Number
Date of Purchase
Purchase Location

Owner's Manual

Safety Guidelines - Definitions

This manual contains important information that you need to know and understand in order to assure YOUR SAFETY and PROPER OPERATION OF EQUIPMENT. The following symbols help you recognize this information. Please read the manual and pay attention to these sections.

Save These Important Safety Instructions!

Read and understand all of these safety instructions. Be sure to retain them for future use.



WARNING!

WARNINGS INDICATE A CERTAINTY OR STRONG POSSIBILITY OF PERSONAL INJURY OR DEATH IF INSTRUCTIONS ARE NOT FOLLOWED.



CAUTION:

CAUTIONS INDICATE A POSSIBILITY OF EQUIPMENT DAMAGE IF INSTRUCTIONS ARE NOT FOLLOWED PROPERLY.



Note: Notes give helpful information.



WARNING!

IMPROPER OPERATION OR MAINTENANCE OF THIS PRODUCT COULD RESULT IN SERIOUS INJURY AND PROPERTY DAMAGE. READ AND UNDERSTAND ALL WARNINGS AND OPERATING INSTRUCTIONS BEFORE USING THIS EQUIPMENT. BASIC SAFETY PRECAUTIONS SHOULD ALWAYS BE FOLLOWED TO REDUCE THE RISK OF PERSONAL INJURY.



Save These Important Safety Instructions!

Read and understand all of these safety instructions. Be sure to retain them for future use.

Owner's Manual

General Safety Precautions



WARNING!

FAILURE TO FOLLOW THESE INSTRUCTIONS CAN RESULT IN SEVERE INJURY OR DEATH.



CAUTION:

FAILURE TO FOLLOW THESE INSTRUCTIONS CAN ALSO RESULT IN DAMAGE TO THE EQUIPMENT AND/OR THE ITEM YOU ARE WORKING ON OR WITH.

Carbon Monoxide

- Carbon Monoxide is an odorless and colorless gas. Breathing exhaust that contains this poisonous gas can cause unconsciousness and may lead to death.
- The engine exhaust from this product contains chemicals recognized by the state of California to cause cancer, birth defects, or other reproductive harm.
- When this tool is running, ensure that the area is well ventilated. Never run the engine in an enclosed area. Run the engine in an open area or with an exhaust evacuation system in an enclosed area.
- NEVER use a generator inside homes, garages, crawlspaces, or other partially enclosed areas. Deadly levels of carbon monoxide can build up in these areas. Using a fan or opening windows and doors does NOT supply enough fresh air.
- ONLY use a generator outdoors and far away from open windows, doors, and vents. These openings can pull in generator exhaust.
- Even when you use a generator correctly, CO may leak into the home. ALWAYS use a battery-powered or battery-backup CO alarm in the home.
- If you start to feel sick, dizzy, or weak after the generator has been running, move to fresh air RIGHT AWAY. See a doctor. You could have carbon monoxide poisoning.



WARNING!

THE EXHAUST CONTAINS POISONOUS CARBON MONOXIDE GAS THAT CAN CAUSE LOSS OF CONSCIOUSNESS AND MAY LEAD TO DEATH.

Gasoline and Oil

This product requires oil and fuel. THE ENGINE WILL NOT START WITHOUT OIL. Work in well ventilated area. Keep cigarettes, flames or sparks away from the work area or where gasoline is stored.



WARNING!

GASOLINE IS EXTREMELY FLAMMABLE AND IS EXPLOSIVE UNDER CERTAIN CONDITIONS. KEEP OUT OF REACH OF CHILDREN.

Owner's Manual

General Safety Precautions (cont'd)



Gasoline and Oil (cont'd)

- Gasoline fuel and fumes are flammable and potentially explosive. Use proper fuel storage and handling procedures. Always have multiple ABC class fire extinguishers nearby.
- Keep the generator and surrounding area clean at all times. Keep the generator at least 5 feet away from buildings and other equipment during operation.
- Fuel or oil spills must be cleaned up immediately. Dispose of fluids and cleaning materials as per any local, state, or federal codes and regulations. Store oily rags in a covered metal container.
- Never store fuel or other flammable materials near the generator.
- Do not smoke, or allow sparks, flames or other sources of ignition around the engine and fuel tank. Fuel vapors are explosive.
- Keep grounded conductive objects, such as tools, away from exposed, live electrical parts and connections to avoid sparking or arcing. These events could ignite fumes or vapors.
- Do not refill the fuel tank while the engine is running or while the engine is still hot. Do not operate the generator with known leaks in the fuel system.
- Excessive buildup of unburned fuel gases in the exhaust system can create a potentially explosive condition. This buildup can occur after repeated failed start attempts, valve testing, or hot engine shutdown. If this occurs, open exhaust system drain plugs, if equipped, and allow the gases to dissipate before attempting to restart the generator.
- Use only engine manufacturer recommended fuel and oil.

Propane



WARNING!

- Propane gas is **EXTREMELY FLAMMABLE**
- Propane gas Leaks are **DANGEROUS**
- Propane vapors may ignite **EXPLOSIVELY**
- Propane gas may cause **SUFFOCATION**
- Escaping propane may cause **FREEZE BURNS**
- Propane gas is **HEAVIER THAN AIR**
- Do not smoke, or allow sparks, flames or other sources of ignition around the engine and fuel tank. Fuel vapors are explosive.
- Keep grounded conductive objects, such as tools, away from exposed, live electrical parts and connections to avoid sparking or arcing. These events could ignite fumes or vapors.

Hot Components

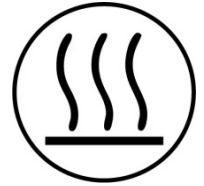

WARNING!

HOT EXHAUST CAN BURN YOU. ENGINE AND EXHAUST SYSTEM PARTS BECOME VERY HOT AND REMAIN HOT FOR SOME TIME AFTER THE ENGINE IS RUN. WEAR INSULATED GLOVES OR WAIT UNTIL THE ENGINE AND EXHAUST SYSTEM HAVE COOLED BEFORE HANDLING THESE PARTS.

Power Output

This generator is not designed to power sensitive electronic equipment (including computers and medical devices) without the addition of an approved line conditioner, which is sold separately.



CAUTION:

ATTEMPTING TO POWER SENSITIVE ELECTRONIC EQUIPMENT WITHOUT THE USE OF AN APPROVED LINE CONDITIONER MAY CAUSE DAMAGE TO THE EQUIPMENT.

Work Area

- Keep your work area clean and well lit. Cluttered benches and dark areas invite accidents.
- Do not operate power tools in explosive atmospheres, such as in the presence of flammable liquids, gases, or dust. Generators create sparks which may ignite the dust or fumes.
- Keep bystanders, children, and visitors away while operating a generator. Provide barriers or shields as needed.

Owner's Manual

General Safety Precautions (cont'd)

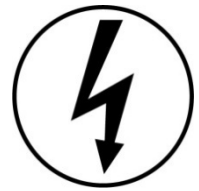

Electrical Safety

- Keep all electrical equipment clean and dry. Replace any wiring where the insulation is cracked, cut eroded part or otherwise degraded. Replace terminals that are worn, discolored, or corroded. Keep terminals clean and tight.
- Insulate all connections and disconnected wires.
- Do not abuse the power cord. Keep power cords away from heat, oil, sharp edges, or moving parts. Replace damaged power cords immediately. Damaged power cords increase the risk of electric shock.
- Do not operate the generator with wet hands. Do not expose generator to rain, snow or wet conditions. Water will increase the risk of electric shock. The generator is a potential source of electrical shock if not kept dry.
- Do not attempt to connect or disconnect load connections while standing in water, or on wet or soggy ground.
- Do not touch electrically energized parts of the generator and interconnecting cables or conductors with any part of the body, or with any non-insulated conductive object.
- Avoid body contact with grounded surfaces such as pipes, radiators, ranges, and refrigerators. There is an increased risk of electric shock if your body is grounded.
- When operating a power tool outside, use an outdoor extension cord marked "W-A" or "W". These extension cords are rated for outdoor use, and reduce the risk of electric shock.
- Grounded tools must be plugged into an outlet properly installed and grounded in accordance with all codes and ordinances. Never remove the grounding prong or modify the plug in any way. Do not use any adapter plugs.
- Double insulated tools are equipped with a polarized plug where one blade is wider than the other. This plug fits in a polarized outlet only one way. If the plug does not fit fully in the outlet, reverse the plug. If it still does not fit, contact a qualified electrician to install a polarized outlet. Do not change the plug in any way. Double insulation eliminates the need for the three-wire grounded power cord and grounded power supply system.
- Before servicing equipment powered by the generator, disconnect the equipment from its power input.
- The generator must be earth-grounded for fixed installations in accordance with all relevant electrical codes and standards before operation.
- Grounding provides a low-resistance path to carry electricity away from the user in the event of an electrical malfunction.
- All connections and conduits from the generator to the load must only be installed by trained and licensed electricians and in compliance with all relevant local, state, and federal electrical codes and standards, and other regulations where applicable.
- Connect the generator only to a load or electrical system (110/120 volt) that is compatible with the electrical characteristics and rated capacities of the generator.
- **NEVER** try to power building or home wiring by plugging the generator into a wall outlet, a practice known as "backfeeding." This is extremely dangerous and presents an electrocution risk to utility workers and neighbors served by the same utility transformer. It also bypasses some of the built-in household circuit protection devices.

Personal Safety



CAUTION:

DO NOT SIT, STAND, OR PLACE OBJECTS ON TOP OF THE GENERATORS FUEL TANK. REGARDLESS OF WHETHER IT IS RUNNING OR NOT.

- Stay alert. Watch what you are doing, and use common sense when operating a generator. Do not use generator while tired or under the influence of drugs, alcohol, or medication. A moment of inattention while operating generators may result in serious personal injury.
- Make note of the location of the engine power switch should you need to turn off the generator quickly.
- Dress properly. Contain long hair, clothing, jewelry, and gloves as they can be caught in moving parts.
- Avoid accidental starting. Make sure the power switch is in its "OFF" position, and disconnect the spark plug wire when not in use.

7500 Generator

General Safety Precautions (cont'd)

Personal Safety (cont'd)

- Remove adjusting keys or wrenches before turning the generator on. A wrench or a key that is left attached to a rotating part of the generator may result in personal injury.
- Do not overreach. Keep proper footing and balance at all times.
- Use safety equipment. Always wear eye protection. Wear ANSI approved safety impact eye goggles. Dust mask, non-skid safety shoes, safety gloves, hard hat, or hearing protection must be used for appropriate conditions.
- **Do not use the generator if the power switch does not turn it on or off. Any generator that cannot be controlled with the power switch is dangerous and must be replaced.**
- **Do not force the generator. Use the correct generator for your application. The correct generator will do the job better and safer at the rate for which it is designed.**
- The generator weighs 187 lbs. Two or more people should assist when moving or lifting this product. Never lift the Generator using the engine or alternator lifting lugs. Connect lifting equipment to the Frame of the generator.

General Use and Care

- Make sure the power switch is in its “OFF” position and disconnect the spark plug wire before making any adjustment, changing accessories, or storing the generator. Such preventive safety measures reduce the risk of starting the generator accidentally.
- Store idle generators out of reach of children and other untrained persons. Generators are dangerous in the hands of untrained users.
- Maintain generators with care. Do not use a damaged generator. Tag damaged generators “Do not use” until repaired.
- Check for misalignment or binding of moving parts, breakage of parts, and any other condition that may affect the generator’s operation. If damaged, have the generator serviced before using. Many accidents are caused by poorly maintained generators.
- Use only accessories that are recommended by the manufacturer for your model. Accessories that may be suitable for one generator may become hazardous when used on another generator.

Servicing

- Maintain labels and name plates on the generator and engine. These carry important information. If unreadable or missing, contact Smarter Tools immediately for a replacement.
- Generator service must be performed only by qualified repair personnel. Service or maintenance performed by unqualified personnel could result in a risk of injury.
- When servicing a generator, use only identical replacement parts. Follow all appropriate instructions in this manual. Use of unauthorized parts or failure to follow maintenance instructions may create a risk of electric shock or injury.



WARNING!

PEOPLE WITH PACEMAKERS SHOULD CONSULT THEIR PHYSICIAN(S) BEFORE USING THIS PRODUCT. ELECTROMAGNETIC FIELDS IN CLOSE PROXIMITY TO A HEART PACEMAKER COULD CAUSE INTERFERENCE TO OR FAILURE OF THE PACEMAKER.

Owner's Manual

General Safety Precautions (cont'd)

Installation

- Ensure installation meets all applicable safety, and local and national electrical codes. Have installation performed by a qualified, licensed electrician and building contractor.
- All electrical work, including the earth-ground connection, should be completed by a licensed electrician.
- Any separate fuel storage or generator supply facility must be built or installed in full compliance with all relevant local, state, and federal regulations.
- It is recommended to use the generator only in well ventilated outdoor areas. A running gasoline engine will generate carbon monoxide, a colorless, odorless gas that, if inhaled, can cause serious injury or death. If the generator is installed indoors, exhaust fumes must be piped out of the building using leak-free, heat resistant piping. Pipes and silencer should not use any flammable materials, nor should they be installed near the same. Generator exhaust fumes must be within legal limits and installation must always meet local building codes.
- If the generator is installed outdoors, it must be weatherproofed and should be soundproofed. It should not be run outdoors without protection of the generator and wiring conduit.
- Two or more people should assist when moving or lifting this product. Never lift the Generator using the engine or alternator lifting lugs. Connect lifting equipment to the Frame of the generator.
- Before lifting the generator, ensure the lift rigging and supporting structure are in good condition, and are rated to lift such a load.
- Keep all personnel away from the suspended generator during relocating.
- The supporting floor/ground surface should be level, and strong enough to safely hold the weight of the generator. If the floor/grounded surface is not level, strong cross members should be placed under the full length of the generator frame at its low side.
- For trailer installation, the generator should be mounted on the center point of the trailer, over the wheels. The trailer must be capable of supporting the weight of the generator and all contents (tools, etc.)
- Install sound-and weather-proofing only when it is not raining or snowing to avoid trapping moisture within the generator's area.

Mechanical

- Always make sure the power switch is in its "OFF" position. Disconnect the spark plug wire, and allow the engine to completely cool before carrying out maintenance.
- Check for damaged parts. Before using the generator, any part that appears damaged should be carefully checked to determine that it will operate properly and perform its intended function. Check for alignment and binding of moving parts, any broken parts or mounting fixtures, and any other condition that may affect proper operation technician.
- The generator is designed with guards for protection from moving parts. In any case, care must still be taken to protect personnel and equipment from other mechanical hazards when working around the generator.
- Do not operate the generator with safety guards removed. While the generator is running, do not attempt to reach around the safety guard for maintenance or any other reason.
- Keep hands, arms, long hair, loose clothing, and jewelry away from moving parts. Be aware that when engine parts are moving fast they cannot be seen clearly.
- Keep access doors on enclosures closed and locked when access is not required.
- When working on or around the generator always wear protective clothing including ANSI approved safety gloves, safety eye goggles, and safety hat.
- Do not alter or adjust any part of the generator that is assembled and supplied by the manufacturer.
- Always follow and complete scheduled engine and generator maintenance.

Owner's Manual

General Safety Precautions (cont'd)

Chemicals

- Avoid contact with hot fuel, oil, exhaust fumes, and hot solid surfaces.
- Avoid body contact with fuels, oils, and lubricants used in the generator. If swallowed, seek medical treatment immediately. Do not induce vomiting if fuel is swallowed. For skin contact, immediately wash with soap and water. For eye contact, immediately flush eyes with clean water and seek medical attention.

Noise

Prolonged exposure to noise levels above 85dBA is hazardous to hearing.

Always wear ANSI approved ear protection when operating or working around the Generator when it is running.

Extension Cords

If an extension cord (not included) is used, make sure to use only UL approved cords having the correct gauge and length according to the following table:

Nameplate Amps (@full load)	Cord Lengths			
	0'-50'	50'-100'	100'-150'	150'-200'
0-5	16	16	12	12
5.1-8	16	14	10	-
8.1-12	14	12	-	-
12.1-15	12	10	-	-
15-20	10	10	-	-

7500 Generator

Controls and Features

Familiarize yourself with the location and function of the controls and features before operating your generator. Save this manual for future reference.

Generator

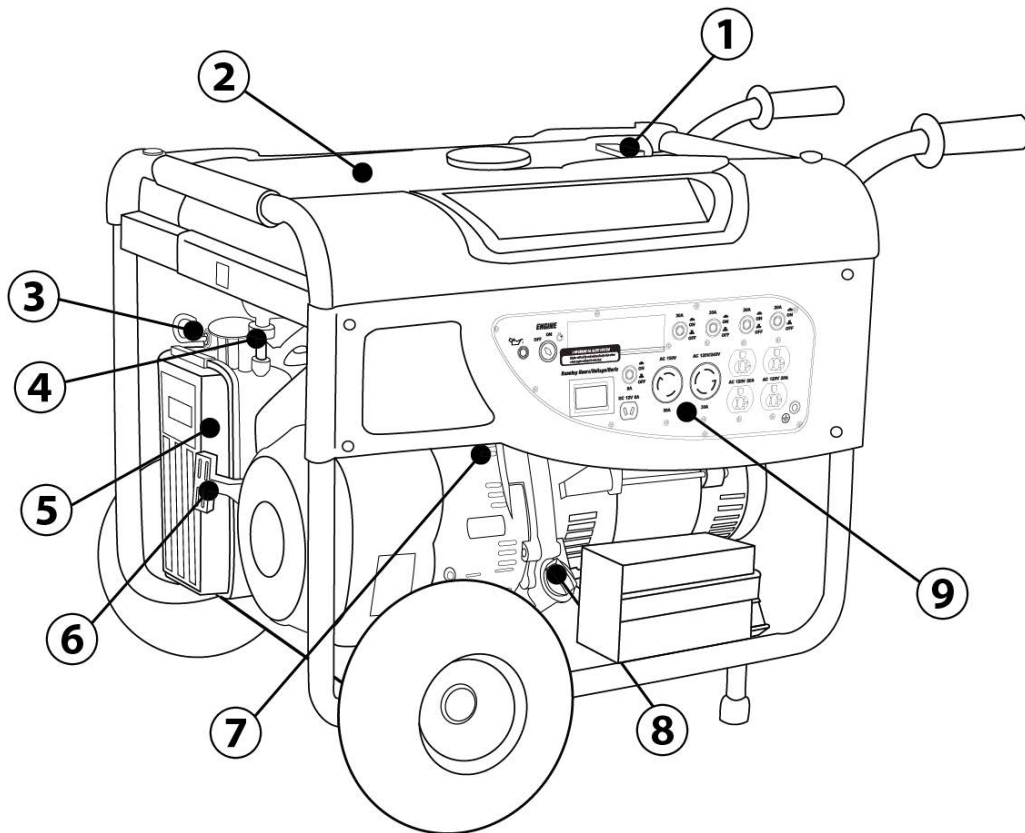

1. **Fuel Gauge** – Indicates amount of fuel in tank.
2. **Fuel Tank** – 7 gallon capacity
3. **Choke** – Used to start engine.
4. **Fuel Valve** – Turn this valve to the on position to supply fuel to the engine
5. **Air Filter** – Protects the engine by filtering dust and debris from the intake air.
6. **Recoil Starter** – Used to start the engine.
7. **Low Oil Shutdown** – Senses the level of oil in the crankcase and shuts the engine down if the level falls too low.
8. **Oil Filler Cap/Dipstick** – Used to check and fill engine oil.
9. **Control Panel** – See “Control Panel” page 14

7500 Generator

Controls and Features (cont'd)

Control Panel

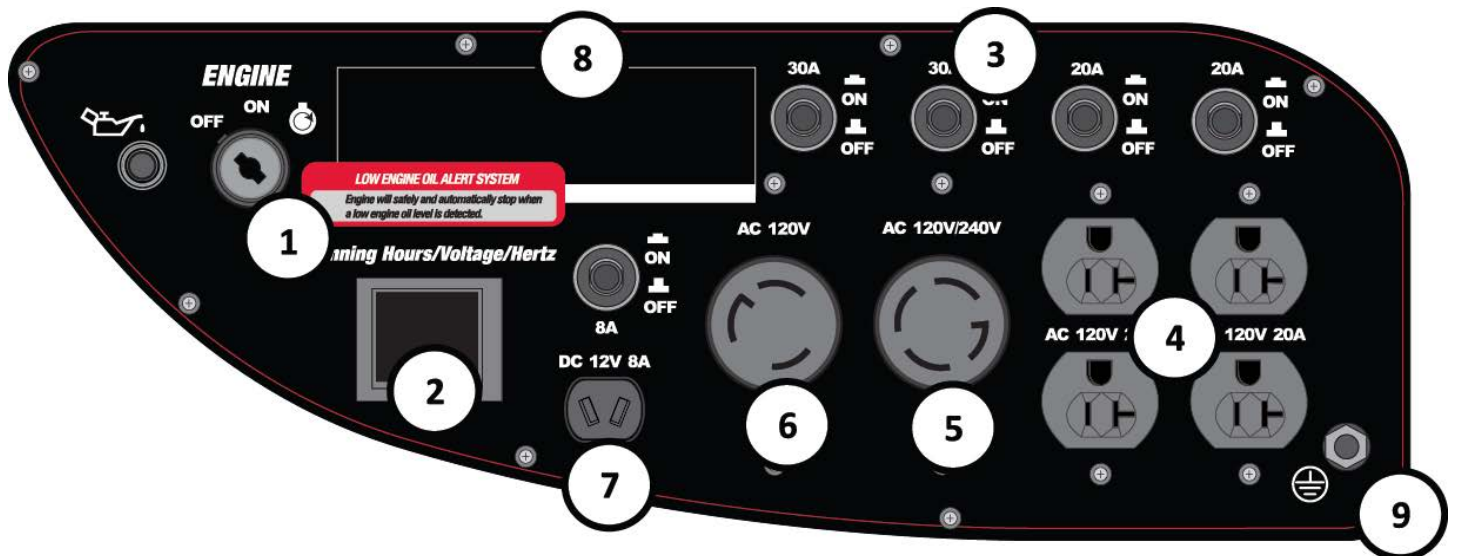

1. **Engine Switch** – Used to turn on and off the engine. For electric models it is also used to start the engine.
2. **Hour Meter** – Measures the number of hours the engine has run and displays the voltage/Hz produced by generator.
3. **Circuit Breakers** – Protects the generator against electrical overload.
4. **(2) 120V 20A Duplexes** – These duplexes are protected by a (2) 20A circuit breakers. Use each duplex to operate 120 volt AC, single phase, 60 Hz loads requiring up to 20 A or 2400 Watts of power.
5. **120/240V 30A Twist-Lock** – Protected by a 30A circuit breaker on each 120 Volt leg of the receptacle. This receptacle powers 240 Volt AC, 60 Hz, single phase loads requiring up to 30A or 7200 Watts of power. If an L14-30P plug is wired for only one 120 Volt leg (3-wire connection) then this receptacle powers 120 Volt AC, 60 Hz, single phase loads requiring up to 30A or 3600 Watts of power.
6. **120V 30A Twist-Lock**– This outlet is protected by a 30A circuit breaker. Use this Twist-Lock to operate 120 volt AC, single phase, 60 Hz loads requiring up to 30A or 3600 Watts of power.
7. **12V DC Connectors** – Use to charge 12V DC batteries
8. **General Specifications**
9. **Ground Terminal** – Consult an electrician for local grounding regulations.

7500 Generator

Installation



Note: Prior to powering tools and equipment, make sure the generator's rated voltage, wattage, and amperage capacity (120V-62.5AMPs) is adequate to supply all electrical loads that the unit will power. If powering exceeds the generator's capacity, it may be necessary to group one or more of the tools and/or equipment for connection to a separate generator.

Electrical and other permits may be required for the installation of emergency power systems. Investigate your local building and electrical codes before installing this unit. Installation must be completed by licensed contractors.



WARNING!

THE GENERATOR WEIGHS APPROXIMATELY 190 POUNDS. USE CARE AND THE PROPER LIFTING OR HOISTING EQUIPMENT WHEN MOVING IT TO THE INSTALLATION LOCATION. ALWAYS CONNECT HOSE LINES TO THE FRAME OF THE GENERATOR.



CAUTION:

DO NOT ADD OIL OR GASOLINE UNTIL INSTALLATION IS COMPLETE.

General Location



CAUTION:

GENERATOR SHOULD ONLY BE OPERATED ON A LEVEL SERVICE. DO NOT OPERATE GENERATOR ON LOOSE GROUND OR OBVIOUS INCLINES. THE LOW OIL SHUT DOWN FEATURE MAY BE PREMATURELY ACTIVATED IN THESE CASES CAUSING THE UNIT TO NOT START.

- Make sure to locate and install the generator outdoors where cooling air is readily available.
- Install the generator so that the air inlets and outlets are not blocked by obstructions such as bushes, trees, or snow drifts. Locating it in the path of heavy winds or snowdrifts may require the placement of a barrier for protection. In normal weather conditions, the air vent should face the prevailing wind direction.
- Install the generator on a concrete slab or other area where rain drainage or flood waters cannot reach it.
- Generator placement should allow four feet of access to all sides for maintenance.
- Place the generator as close as possible to the electrical tools and equipment being powered to reduce the length of extension cords.
- If the generator is located indoors the engine exhaust must be ventilated to the outdoors using leak-proof, heat resistant flexible metal, flex tubing.



Note: Generators used on construction sites may be subject to additional rules and regulations. If you plan to use the generator on a construction site, please consult your local authority regarding.

7500 Generator

Installation (cont'd)

Wheel and Handle Kit Installation

(Installation requires a socket wrench with 10mm, 14mm, and 17mm sockets).

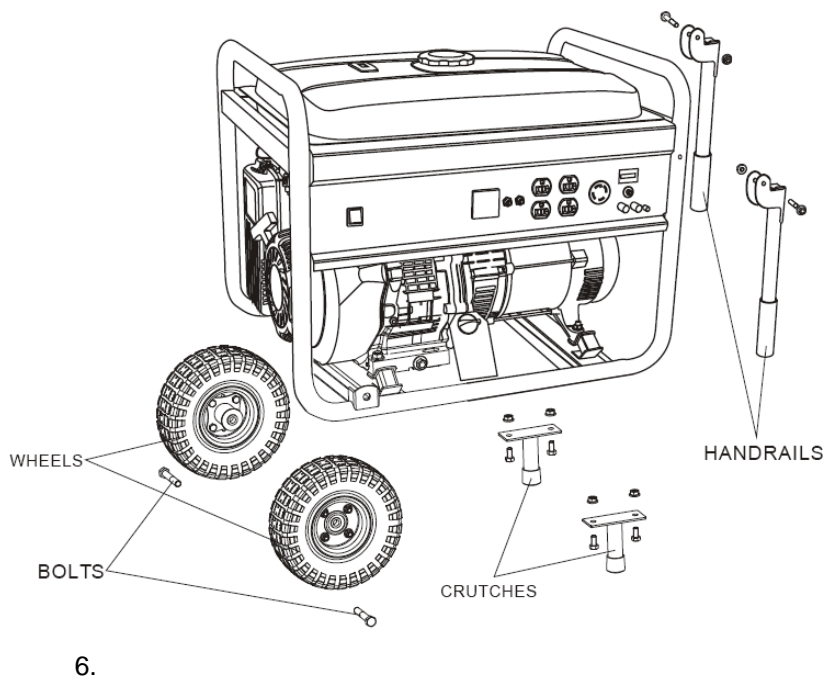

1. Before adding oil or gasoline to the engine, tip the generator slowly so that the recoil and air filter are up.
2. Install the two wheels on the generator using the (2) 17mm 2 1/2" bolts provided. Make sure the valve stem is facing outward.
3. Tip the generator slowly so that the recoil and air filter are down.
4. Install the crutches on the under frame with the (4) nuts and 14mm 1" bolts provided.
5. Tip the generator slowly so that it sits on both the wheels and crutched.

Install the handrails on the right side of the frame using the (2) nuts and 10mm 1 3/4" bolts provided.

Support and Mounting

Mount the generator on a concrete slab capable of supporting the weight of the generator. The slab must extend on all sides beyond the frame by at least one foot. Contact a cement contractor for slab specifications if necessary. Attach the frame to the concrete slab using 3/8" diameter expansion anchor bolts (not supplied).

Grounding



Note: It is recommended that only a trained and licensed electrician perform this procedure.



Connect a #6 AWG grounding wire (not included) from the ground connector on the generator to a grounding rod (not included) that has been driven at least 24 inches deep into the earth. The grounding rod must be an earth-driven copper or brass rod (electrode) which can adequately ground the generator.

7500 Generator

Installation (cont'd)



Note: Models using the electric starter require a 12V battery with a minimum of 17AH. While higher Amp Hour batteries may be used, do not attempt to start the engine using a battery rated for a lower or higher Voltage.

Connect the Battery

1. Place battery into battery cradle and secure.
2. Remove the protective cover from the positive (red) battery lead. *Positive lead is marked with a “+”.*
3. Attach the positive lead to the positive terminal (marked with a “+”) on the battery with the phillips-head cap screw and secure with 8mm nut.
4. Remove the protective cover from the negative (black) battery lead. *Negative lead is marked with a “-”.*
5. Attach the negative lead to the negative terminal (marked with a “-”) on the battery with the phillips-head cap screw and secure with 8mm nut.



CAUTION:

PRIOR TO FIRST USING THE GENERATOR, THE ENGINE MUST BE FILLED WITH APPROXIMATELY 1 QUART OF HIGH QUALITY SAE 10W-30 GRADE ENGINE OIL.

Add Engine Oil

1. Place the generator on a flat and level surface.
2. Remove oil fill cap/dipstick to add oil.
3. Add approximately 1 quart of high quality SAE 10W-30 grade engine oil.
4. Check engine oil daily and add as needed.

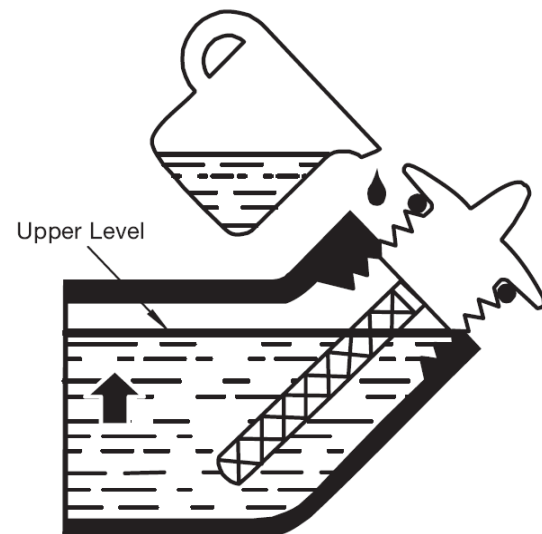

Add Fuel

1. Use clean, fresh, regular unleaded fuel with a minimum octane rating of 85.
2. DO NOT mix oil with fuel.
3. Clean area around the fuel cap.
4. Remove the fuel cap.
5. Be sure that the fuel strainer is in place.
6. Slowly add fuel to the tank. DO NOT overfill. Allow approximately ¼ inch of space for fuel expansion.
7. DO NOT fill above fuel strainer.
8. Screw on the fuel cap and wipe away and spilled fuel.



WARNING:

THE GENERATOR MUST BE OFF AND COOLED DOWN BEFORE REFILLING THE FUEL TANK.

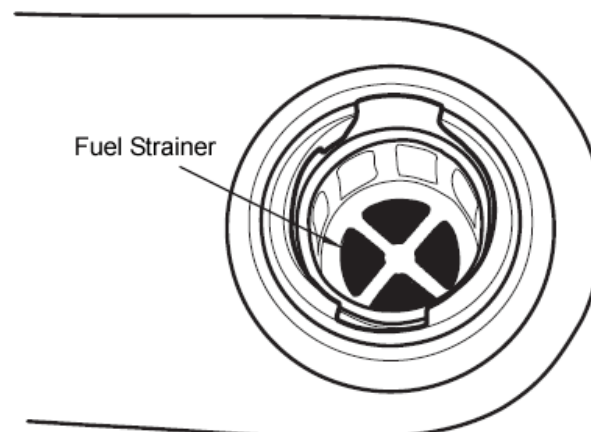

7500 Generator

Operation

Starting the Generator Using Gasoline

1. Make sure the generator is on a flat and level surface.
2. Make sure the electrical powered tools/equipment that will be used are not plugged into the generator while the engine is started.
3. Turn the 120 volt AC circuit breaker to its "ON" position.
4. Turn the fuel valve to the "ON" position.
5. Pull the choke rod out.
6. Turn the engine power switch to its "ON" position.
7. For "Electric Start" models (9500E and 9500EB), turn key to the start position and hold until engine starts. If the engine fails to start within 5 seconds, release the key and wait at least 10 seconds before attempting to start the engine again.
8. For "Recoil Start", hold the start handle loosely and pull it slowly several times to allow the gasoline to flow into the engine's carburetor. Then hold the start handle firmly and pull the rope hard and fast. Pull the rope all the way out, using two hands if necessary. If necessary pull the rope several times until the engine starts.
9. Allow the engine to idle until warm. Then, slowly push choke rod in all the way.



Note: *If the engine starts but does not run, make certain that the generator is on a flat, level surface. The engine is equipped with a low oil sensor that will prevent the engine from running when the oil level falls below a critical threshold.*

Connecting the Propane Fuel Supply

1. Connect provided hose to gas inlet. Tighten clamp. (Ensure that hose is completely seated on gas inlet before tightening.)
2. Connect universal connector to propane fuel supply.
3. Open valve on propane fuel supply.
4. Make sure all connections are sealed. (You can spray a solution of soap and water on the connections—if bubbles appear – there is a leak! Close valve, remove leaking connection and reconnect-Retest)

Starting the Generator Using Propane

OPERATE THE ENGINE IN A WELL VENTILATED AREA.

DO NOT connect any electrical devices to the outlets on the generator before starting the engine.

1. Make sure the fuel (gasoline) petcock is in "Off" position.
2. Make sure hose is properly connected to generator.
3. Connect the Regulator to the liquid propane gas supply and open the liquid propane gas supply, Ensure there are no leaks.
4. Leave the choke in the "in/unchoked" position
5. Turn the ignition switch to "ON".
6. Pull slowly on the recoil starter until it is engaged, then pull it briskly. [For models with battery, simply turn ignition until generator starts.]
7. After the engine starts, warm up the engine
8. Proceed to connect electrical devices. Remember not to exceed maximum wattage.

Switching From Gasoline to Propane

1. Disconnect all load from generator.
2. Make sure propane hoses are properly connected.
3. While the unit is running on gasoline, turn Off the fuel valve.
4. When the generator starts to sputter, open the valve on the propane bottle. (if bottle is newly connected press pressure release valve on regulator on generator and press for 2 seconds and release)
5. Reconnect load when unit is running smoothly.

Switching From Propane to Gasoline

1. Disconnect all load from generator.
2. While the unit is still running, open the gasoline valve.
3. Immediately close the valve on the propane bottle.
4. Reconnect load when unit is running smoothly.

Surge Protection



CAUTION:

ATTEMPTING TO POWER SENSITIVE ELECTRONIC EQUIPMENT WITHOUT THE USE OF AN APPROVED LINE CONDITIONER MAY CAUSE DAMAGE TO THE EQUIPMENT.

Electronic devices, including computers and many programmable appliances use components that are designed to operate within a narrow voltage range and may be affected by momentary voltage fluctuations.

While there is no way to prevent voltage fluctuations, you can take steps to protect sensitive electronic equipment.

1. *Install UL1449, CSA-listed, plug-in surge suppressors on the outlets feeding your sensitive equipment.* Surge suppressors come in single- or multi-outlet styles. They're designed to protect against virtually all short duration voltage fluctuations.
2. *Obtain an Uninterruptible Power Supply (UPS) device. Most UPS devices come with a rechargeable battery between the electronic equipment and power supply source. The device buffers the voltage and protects against virtually all short duration voltage fluctuations.*

Capacity

Follow these simple steps to calculate the running and starting watts necessary for your purposes.

See page 16 for *Wattage Reference Guide*.

1. Select the electrical devices you plan on running at the same time.
2. Total the running watts of these items. This is the amount of power you need to keep your items running.
3. Identify the highest starting wattage of all devices identified in step
 - a. Add this number to the number calculated in step
 - b. Surge wattage is the extra burst of power needed to start some electric driven equipment. Following the steps listed under "Power Management" will guarantee that only one device will be starting at a time.

7500 Generator

Operation (cont'd)

Power Management

Use the following formula to convert voltage and amperage to watts:
Volts x Amps = Watts

To prolong the life of your generator and attached devices, follow these steps to add electrical load:

1. Start the generator with no electrical load attached.
2. Allow the engine to run for several minutes to stabilize.
3. Plug in and turn on the first item. It is best to attach the item with the largest load first.
4. Allow the engine to stabilize.
5. Plug in and turn on the next item.
6. Allow the engine to stabilize.
7. Repeat steps 5-6 for each additional

Connecting Electrical Loads

1. Let the engine stabilize and warm up a few minutes after starting.
2. Prior to powering tools and equipment, make sure the generator's rated voltage, and amperage capacity (110/120VAC @ 60 AMPs, 12V DC @ 8 AMPs) is adequate to supply all electrical loads that the unit will power. If powering exceeds the generator's capacity, it may be necessary to group one or more of the tools and/or equipment for connection to a separate generator.
3. Once the generator is running, simply connect the power cords of 110/120 volt AC powered tools and equipment into the 110/120 volt AC dual outlets and/or the power cord of a 12V DC powered tool to the DC terminals..



CAUTION:

MAKE SURE TO CONNECT THE POSITIVE (+) LEAD OF THE POWER CORD TO THE POSITIVE (+) TERMINAL ON THE GENERATOR, AND CONNECT THE NEGATIVE (-) LEAD OF THE POWER CORD TO THE NEGATIVE (-) TERMINAL ON THE GENERATOR.

4. If using only a 12V DC tool or equipment, turn the 110/120V AC circuit breaker to its "OFF" position.
5. DO NOT connect 3-phase loads to the generator.
6. DO NOT connect 50Hz loads to the generator.
7. DO NOT overload the generator.



Note: The DC terminals may be used for charging 12 volt automotive type batteries only.

Stopping the Engine

1. Turn off and unplug all electrical loads. Never start or stop the generator with electrical devices plugged in or turned on.
2. Let the generator run at no-load for several minutes to stabilize internal temperatures of the engine and generator.
3. Turn the power switch to the "OFF" position.
4. Turn the fuel valve to the "OFF" position.

7500 Generator

Wattage Reference Guide

Item	Running Watts	Starting Watts
Essentials		
Light Bulb	100	100
Refrigerator/Freezer	1200	2400
Sump Pump	600	1800
Well Pump 1HP	2000	4000
Water Heater	4000	
Security System	180	
AM/FM Radio	300	
Garage Door Opener ½ HP	500	600
Battery Charger 12V	110	
Heating and Cooling		
Air Conditioner 12000 BTU	1700	2500
Fan	300	600
Furnace Fan 1/3 HP	1200	2000
Home Appliances		
Microwave	1000	
Electric Range – One Element	1500	
Electric Skillet	1250	
Coffee Maker	1500	
Clothes Washer	1200	
Entertainment		
CD/DVD Player	100	
Stereo Receiver	450	
Television 27"	500	
PC with 15" Monitor	800	
Job Site		
Belt Sander 3"	1000	1500
Bench Grinder 6"	700	1500
Circular Saw	1500	1500
Compressor 1 ½ HP	1000	1000
Edge Trimmer	500	500
Hand Drill ½"	1000	1000
Paint Sprayer	600	1200
Table Saw	2000	2000

These are estimates only. Check your tool or appliance for exact wattage requirements. The wattages listed are based on estimated wattage requirements. For exact wattages, check the data plate or owner's manual on the item you wish to power using the generator.

Operating voltage and frequency requirement of all electronic equipment should be checked prior to plugging to plugging them into this generator. Damage may result if the equipment is not designed to operate within a +/- 10% voltage variation, and +/- 3 Hz frequency variation from the generator specification plate ratings.

Your Power Needs

Tool or Appliance	Running Watts	Starting Watts
1.		
2.		
3.		
4.		
5.		
Total Running Watts		
	Highest Starting Watts	

Total Running Watts + Highest Starting Watts	
---	--

Owner's Manual

Inspection, Cleaning, and Maintenance

The owner/operator is responsible for all periodic maintenance.



WARNING!

MAKE SURE THE ENGINE POWER SWITCH IS IN ITS "OFF" POSITION. DISCONNECT THE SPARK PLUG WIRE AND ALLOW SUFFICIENT TIME FOR THE ENGINE AND GENERATOR TO COMPLETELY COOL BEFORE PERFORMING ANY INSPECTIONS, MAINTENANCE, OR CLEANING.

- Before each use, inspect the generator. Check for:
 - Loose screws
 - Misaligned or binding moving parts
 - Cracked or broken parts
 - Damaged electrical wiring
 - Any other condition that may affect safe operation.
- If an engine problem occurs, have it checked by a qualified service technical before further use. **DO NOT** use damaged equipment.



WARNING!

NEVER OPERATE A DAMAGED OR DEFECTIVE GENERATOR.

- Before each use, make sure the engine's oil level is at manufacturer's specification. If necessary, fill the crankcase until the oil level is even with the oil fill hole. Make sure there is gas in the unit.
- Before each use, remove all debris with a soft brush, rag, or vacuum.
- Lubricate all moving parts using a premium quality, lightweight machine oil.



CAUTION:

DO NOT ATTEMPT TO ADJUST, MODIFY, OR DISABLE THE FACTORY INSTALLED GOVERNOR. TAMPERING WITH THE FACTORY SET GOVERNOR WILL VOID YOUR WARRANTY.



Note: Complete all scheduled maintenance in a timely manner. Routine maintenance will ensure years of satisfying service out of your product

Changing Oil

Change oil when the engine is warm. Use SAE 10W-30 grade engine oil.

1. Remove the oil drain plug with a 17 mm socket and extension.
2. Allow the oil to drain completely.
3. Replace the drain plug.
4. Remove oil fill cap/dipstick to add oil.
5. Add approximately 1 quart of engine oil and replace oil fill cap/dipstick.
6. Dispose of used oil at an approved waste management facility.

Owner's Manual

Inspection, Cleaning, and Maintenance (cont'd)

Spark Plug

1. Remove the spark plug cable from the spark plug.
2. Use the spark plug tool that shipped with your generator to remove the plug.
3. Inspect the electrode on the plug. It must be clean and not worn to produce the spark required for ignition.
4. Make certain the spark plug gap is 0.7 - 0.8mm (0.028 - 0.031 in.).
5. Carefully thread the plug into the engine.
6. Use the spark plug tool to firmly install the plug.
7. Attach the spark plug wire to the plug.

Air Filter

1. Remove the air filter cover by releasing the snap clips on top and bottom.
2. Remove the foam element.
3. Wash in liquid detergent and water.
4. Squeeze thoroughly dry in a clean cloth.
5. Saturate in clean engine oil.
6. Squeeze in a clean, absorbent cloth to remove all excess oil.
7. Place the filter in the assembly.
8. Reattach the air filter cover and snap clips back in place.

Spark Arrestor (optional)

1. Allow the engine to cool completely before servicing the spark arrester.
2. Remove the two screws holding the cover plate which retains the end of the spark arrester to the muffler.
3. Remove the spark arrester screen.
4. Carefully remove the carbon deposits from the spark arrester screen with a wire brush.
5. Replace the spark arrester if it is damaged.
6. Position the spark arrester in the muffler and attach with the two screws.

Cleaning

- Use a damp cloth to clean exterior surfaces of the engine.
- Use a soft bristle brush to remove dirt and oil.
- Use an air compressor to clear dirt and debris from the engine.
- DO NOT use a garden hose to clean the generator. Water can enter the generator through the cooling slots and damage the generator windings.

Maintenance Schedule

Follow the service intervals indicated in the schedule below.

Service your generator more frequently when operating in adverse conditions.

Every 8 hours of operation or daily

- Check oil level.
- Clean around air intake and muffler.

Every 50 hours of operation or every season

- If operating under heavy load or in hot environments, drain the old engine oil and replace with approximately **1 quart** of *high quality SAE 10W-30 grade engine oil*.
- Remove, clean, re-dampen with motor oil and replace air filter.

Owner's Manual

Inspection, Cleaning, and Maintenance (cont'd)

Maintenance Schedule (cont'd)

Every 100 hours of operation

- Drain the old engine oil and replace with approximately **1 quart** of *high quality SAE 10W-30 grade engine oil*.
- Remove spark plug. Remove any carbon deposits. Check for discoloration. Check spark plug gap (0.7-0.8mm).
- Clean Spark Arrestor (if installed)

Every 150 hours of operation

- Remove, clean, and replace fuel filter.

Every 300 hours of operation

- Have a qualified, certified technician perform thorough maintenance on the generator and engine.
- For long term storage, either drain fuel into a suitable container or add a fuel preservative/stabilizer (not included) to prevent fuel breakdown.

Storage

The generator should be started at least once every 14 days and allowed to run for at least 20 minutes. For longer term storage, please follow these guidelines.

1. Allow the engine to cool completely before storage.
2. Turn off the fuel supply at the fuel valve.
3. Drain all fuel completely from the fuel line and carburetor to prevent gum from forming.
4. Add a fuel stabilizer into the fuel tank.
5. Change the oil.
6. Remove the spark plug and pour about ½ ounce of oil into the cylinder. Crank the engine slowly to distribute the oil and lubricate the cylinder.
7. Reattach the spark plug.
8. Slowly pull the starter grip until resistance is felt. At this point, the piston is coming up on its compression stroke and both the intake and exhaust valves are closed. Storing the engine in this position will help protect it from internal corrosion.
9. Clean the generator according to the instructions in the Maintenance section.
10. Store the unit in a clean, dry area.
11. Store in a clean, dry place out of direct sunlight.

Transporting

If the generator has been used, allow it to cool for at least 15 minutes before loading the generator on the transport vehicle. A hot engine and exhaust system can burn you and can ignite some material. When transporting the generator, turn the engine switch and fuel valve off, and keep the generator level to reduce the possibility of fuel leakage.

Take care not to drop or strike the generator when transporting. **DO NOT** place heavy objects on the generator.

Owner's Manual

Specifications

ST-GP7500DEB

Engine Type	4-Stroke OHV Air Cooled Single Cylinder EPA and CARB Certified
Horsepower	15
Engine Displacement (cc)	389cc
Running Watts	6200w gas/5580 LPG
Starting Watts	7500w gas/6750 LPG
Rated Frequency	60HZ
Rated Voltage	120V/240V
Rated Current	51.6A gas/46.5A LPG
Run Time	10hrs at 50% load
Receptacles (qty.)	(4) 120V AC; (1) 240V/120 AC; (1) 120V 30A AC; (1) 12V 10A DC
Net/Gross Weight	185/187lbs.
Noise Level (dB)	73dB
Fuel Type	Unleaded Gasoline/Liquid Propane Gas
Fuel Capacity (gal.)	7
Oil Level Sensor	Yes
Oil Type	SAE 10W-30
Start Type	Electric /Recoil
AC Volt Meter	Yes
Frame Construction	Tubular Steel
Wheel & Handle Kit	10" No-flat Tires; Dual handles; 3 1/2" crutches
Dimensions L x W x H (in.)	28" x 21.5" x 22"
Battery (optional)	12 Volt 17 Amp Hours Nut & Bolt Terminals

GP750DEB Parts List And Diagrams

Crankcase Assembly

NO.	PARTS NO.	DESCRIPTION	QTY
1	QJ182QDP.01-11	Buse, locating	2
2	157.5-10	SPACER, drain	2
3	157.5-9	BOLT, drain	2
4	QJ150FMG.5-8	DOWEL PIN	2
5	GB/T5787-86	BOLT M6 ×12	4
6	QJ182QDP.01.04	Sensor Assy, Fuel level	1
7	157-1-6-13	NUT	1
8	QJ182QDP.01-01	COVER, CRANKCASE	1
9	QJ168QDJ.01-05	SEAL WASHER	2
10	QJ168QDJ.01-03	PLUG, ADD OIL	1
11	GB/T5787-86	BOLT M8 40	7
12	QJ182QDP.01.01	OIL SEAL 52 34 8	2
13	QJ168QDJ.01-04	OIL LEVEL STICK	1
14	QJ182QDP.01-03	SPACER, CRANKCASE	1
15	GB/T276-94	Bearing6202 15 35 11	2
16	GB/T276-94	Bearing6207 35 72 17	1
17	QJ182QDP.01-10	Pin	1
18	QJ182QDP.01-05	ELECTRONIC SWITCH	1
19	QJ182QDP.01-09	CLIP, Cord	1
20	QJ182QDP.01-08	SEAL GASKET, rubber	1
21	GB/T5787-86	BOLT M6 25	2
22	QJ182QDP.01.03	OIL SEAL	1
23	QJ188FPH.01.01	CRANKCASE ASSY	1

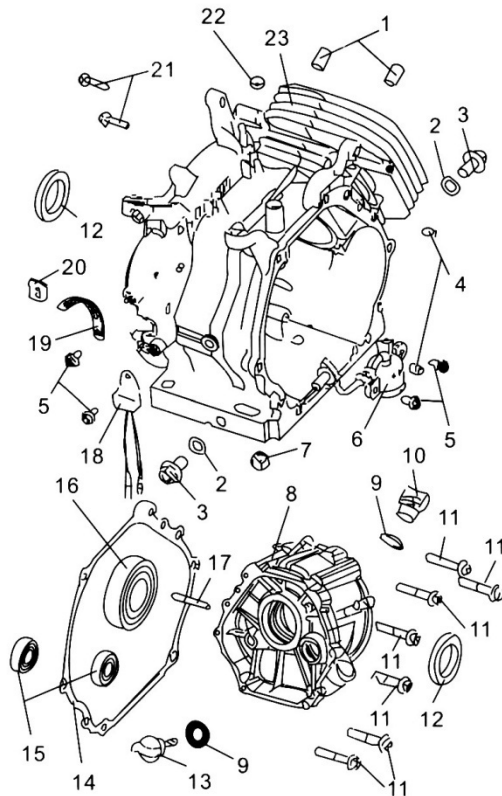

PARTS LIST AND DIAGRAMS

Cylinder Head Assembly

NO.	PARTS NO.	DESCRIPTION	QTY
1	QJ188FPH.02.01	Cylinder Head Assy	1
2	QJ182QDP.02-01	Bolt, Cylinder Head	4
3	JF182FPH-15.02.01	Cover Assy	1
4	QJ182QDP.02-03	Spacer, Seal	1
5	QJ182QDP.02-04	Clamp	1
6	QJ182QDP.02-02	Bolt	1
7	QJ182QDP.02.03	Spacer Assy	1
8	QJ182QDP.02-05	Bolt, Intake Pipe	2
9	QJ182QDP.02-06	Cowling	1
10	GB/T5787-86	Bolt M6 12	1
11	QJ182QDP.02-07	Spacer, Intake Pipe	1
12	QJ182QDP.02.04	Spark Plug	1
13	QJ182QDP.02.02-02	Washer	1
14	QJ182QDP.02.01-05	Canal, Intake Valve	1
15	QJ182QDP.02.01-03	Canal, Exhaust Valve	1
16	QJ182QDP.02.01-04	Ring, Exhaust Valve	1
17	QJ182QDP.02.01-04	Ring, Intake Valve	1
18	GB/T6177-2000	Nut M6	2

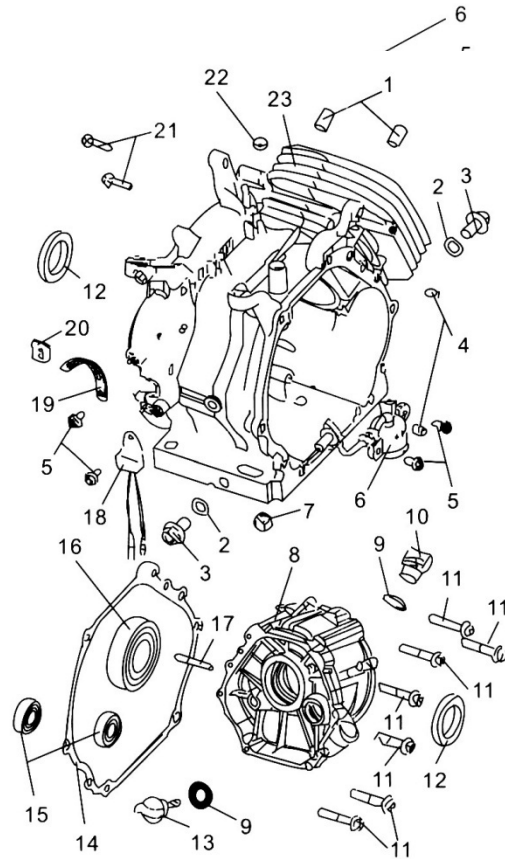

Electromotion Starter Assembly

NO.	PARTS NO.	DESCRIPTION	QTY
1	QJ182FPH-3.03.01	Starter Motor	1
3	QJ188FPH.06.02	Relay Comp.	1
4	QJ182FPH-3.02.02	Charge Winding Comp.	1
5	GB/T5787-1986	Bolt M5*12	1
6	QJ188FPH.06.02.01	Relay Wire	1
7	QJ188FPH.06.03.01	Red Wire	1
8	QJ188FPH.06.03.02	Black Wire	1
9	QJ6500B.02.03	Battery 12V/12Ah	1

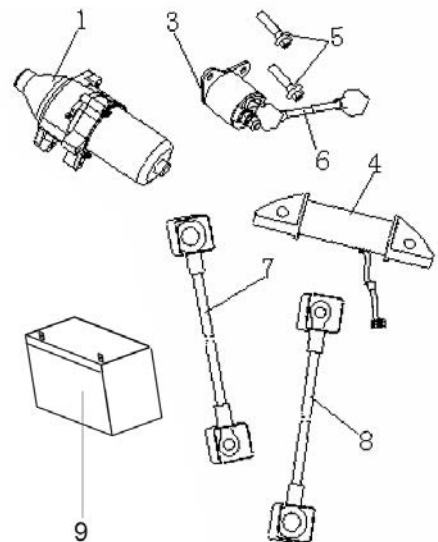

Valve Assembly

NO.	PARTS NO.	DESCRIPTION	QTY
1	QJ182QDP.03-12	Exhaust valve	1
2	QJ182QDP.03-11	Lower retainer	1
3	QJ182QDP.03-05	Valve spring	2
4	QJ182QDP.03-08	Exhaust valve spring retainer	1
5	QJ182QDP.03-09	Valve rotator	1
6	QJ182QDP.03-04	Pivot bolt	2
7	QJ182QDP.03-06	Valve rocker arm	2
8	QJ182QDP.03-07	Rocker arm pivot	2
9	QJ182QDP.03-11	Pivot adjusting nut	2
10	QJ182QDP.03-10	Intake valve spring retainer	1
11	QJ182QDP.03.02	Push rod	2
12	QJ182QDP.03-03	Push rod guide plate	1
13	QJ182QDP.03-13	Intake valve	1
14	QJ182QDP.03-01	Valve lifter	2
15	QJ182QDP.03.01-06	Spring	1
16	QJ182QDP.03.01-02	Pin I	1
17	QJ182QDP.03.01.01-01	Fly clump II	1
18	QJ182QDP.03.01.01-02	Fly clump	1
19	QJ182QDP.03.01.01-03	Pin	2
20	QJ182QDP.03.01-03	Pin IV	1
21	QJ188FPH.03.01-01	Camshaft	1
22	QJ182QDP.03.01-04	Decompress clump	1
23	QJ182QDP.03.01-05	Pin	1
24	QJ188FPH.03.01	Camshaft pump.	1

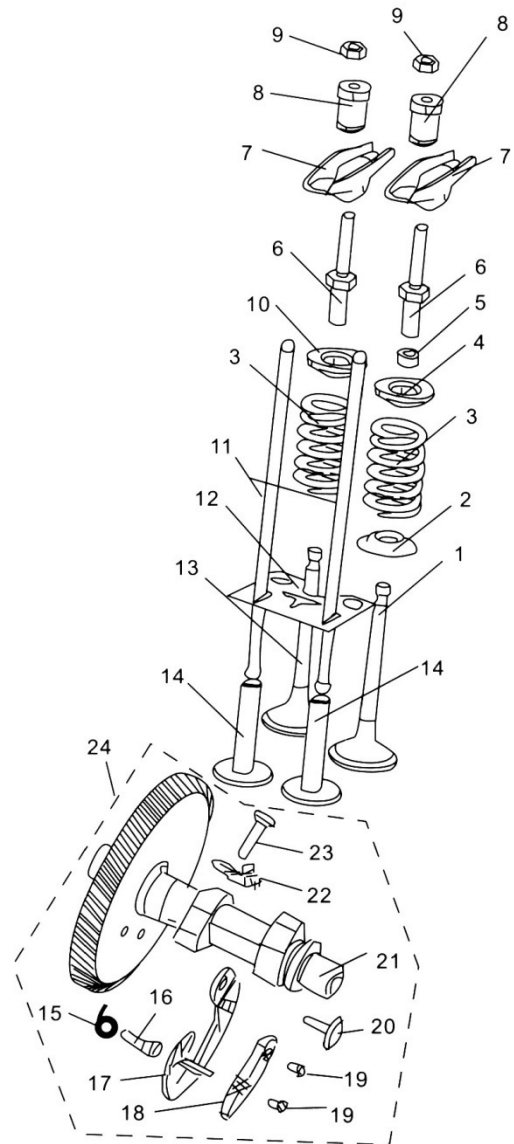

Crankshaft Assembly

NO.	PARTS NO.	DESCRIPTION	QTY
1	QJ182QDP.04-01	BALANCE SHAFT	1
2	QJ182QDP.04-02	NUT	1
3	QJ182QDP.04-03	WOODRUFF KEY	1
4	QJ182QDP.04-04	CRANKSHAFT(1-type) ^{II}	1
5	QJ182QDP.04-05	CRANKSHAFT GEAR I	1
6	QJ182QDP.04-06	CRANKSHAFT GEAR	1
7	GB/T276-94	Bearing 6207	1

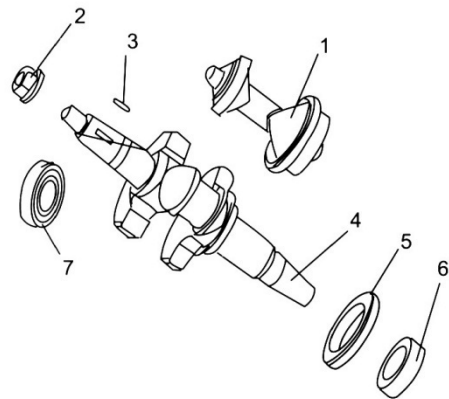

Piston Assembly

NO.	PARTS NO.	DESCRIPTION	QTY
1	QJ188FPH.04-01	PISTON	1
2	QJ188FPH.04-02	RING 1ST	1
3	QJ188FPH.04-03	RING 2ND	1
4	QJ188FPH.04.01	RING SET OIL	1
5	QJ188FPH.04-04	PIN, PISTON	1
6	QJ182QDP.05-05	CIRCLIP	2
7	QJ182QDP.05.02	CONNECTING ROD ASSY	1
8	QJ182QDP.05-02-01	CONNECTING ROD	1
9	QJ182QDP.05-02-02	CONNECTIONG ROD CAP	1
10	QJ182QDP.05-02-03	CONNECTING ROD BOLT	2

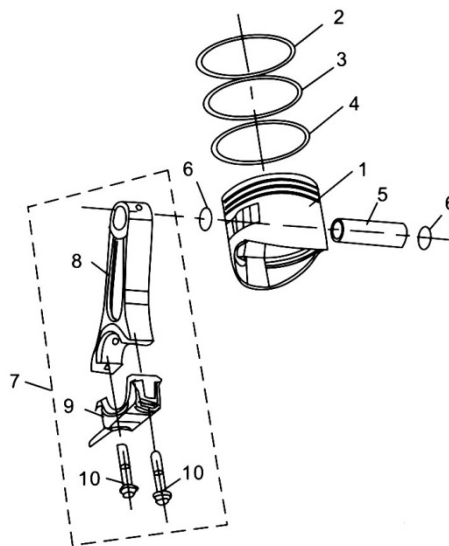

Centrifugal Timing Implement Assembly

NO.	PARTS NO.	DESCRIPTION	QTY
1	QJ182QDP.06-09	Pull Pole, steel wire	1
2	QJ182QDP.06-10	Pull spring,ittle	1
3	QJ182QDP.06-01	Pull Ploe, Timing implement	1
4	QJ182QDP.06-08	Pull spring, big	1
5	GB/T6177-2000	Nut M6	1
6	QJ182QDP.06-05	Washer	1
7	QJ182QDP.06-04	Fork	1
8	QJ182QDP.06-01-03	Governor weight	3
9	QJ182QDP.06-01-02	Governor weight pin	3
10	QJ166QDK.06-07	Washer III	1
11	QJ182QDP.06.01-01	Centrifugal Timing Implement	1
12	QJ166QDK.01-02	Clip	1
13	QJ182QDP.06-07	Washer II	1
14	QJ182QDP.06-06	Handspike Cover	1
15	QJ182QDP.06-02	Clip	1
16	QJ182QDP.06-03	Bolt, Square Toes	1

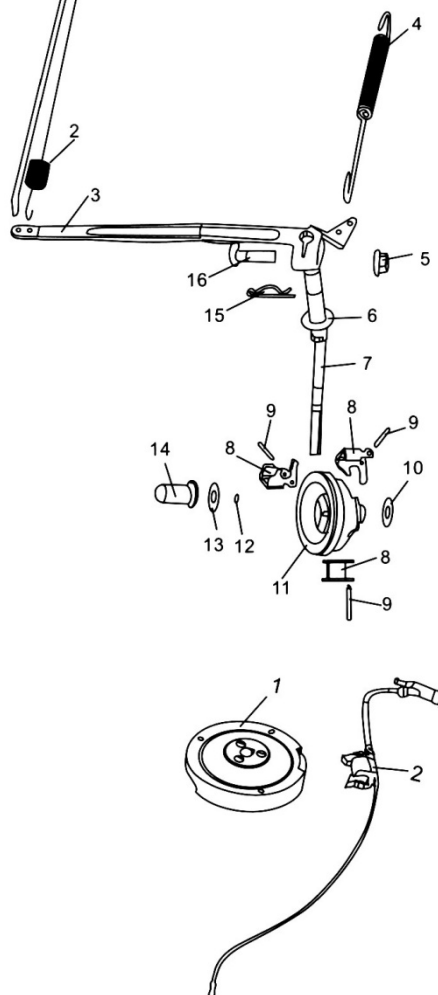

Inflame Assembly

NO.	PART NO.	DESCRIPTION	QTY
1	QJ182FPH-3.02.01	ROTOR ASSY	1
2	QJ182QDP.07.01	high voltage wrap	1

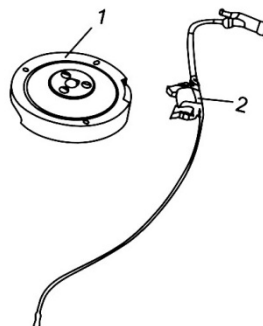

Recoil Assembly

NO.	PARTS NO.	DESCRIPTION	QTY
1	GB/T5789-86	Bolt M6 x 8	3
2	QJ182QDP.08.02	Starter Cover Assy.	1
2.1	QJ168FJH.06.01.02C	Handle Assy.	1
2.2	QJ182FPH-15.03.01B	Starter Cover Assy	1
2.3	QJ182QDP.08.01-09	Clockwork Spring	1
2.4	QJ182QDP.08.01-03	Rotary Table	1
2.5	QJ182QDP.08.01-06	Press Reed	1
2.6	QJ182QDP.08.01-05	Spring, Return	2
2.7	QJ182QDP.08.01-07	Screw	1
2.8	QJ182QDP.08.01-04	Clump	2
2.9	QJ182QDP.08.01-08	Guide Pan	1
2.10	QJ182QDP.08.01-11B	Pull Rope	1
3	GB/T5789-86	Bolt M6 x12	5
4	QJ182QDP.08.01-01	Cowling Assy, cylinder	1
5	QJ182QDP.08-01	Starter Canister	1
6	QJ182QDP.08-02	Fan Wheel	1
7	QJ182FPH-2.03-01	Rubber Plug	1

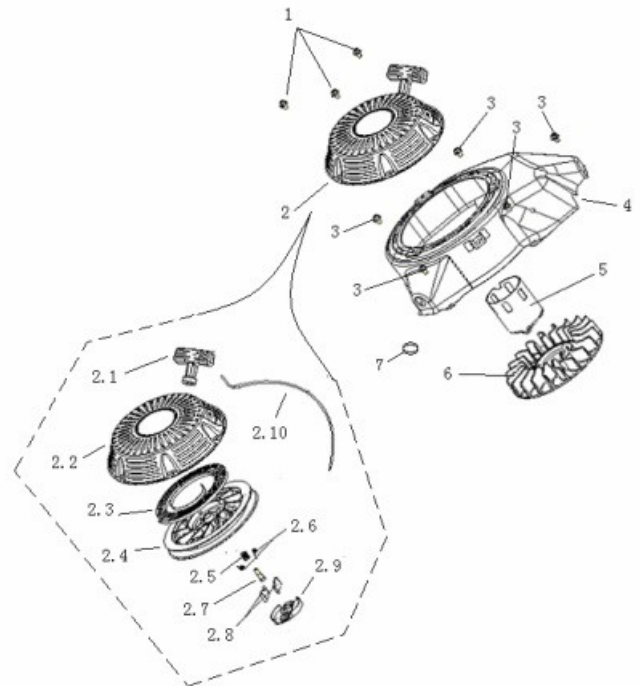

Engine Sprocket Cover

NO.	PARTS NO.	DESCRIPTION	QTY
1	QJ182QDP.09	Speed djustment base assembly	1
2	QJ168QDJ.05.01-02	Spring	1
3	GB/T818-2000	ScrewM5x35	1

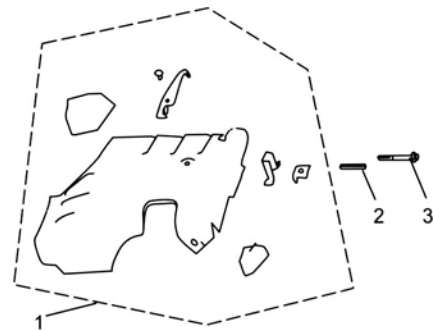

Carburetor Unit

NO.	PARTS NO.	DESCRIPTION	QTY
1	QJ188FPH.05.01D	Carburator Assy	1
2	QJ188FPH.05-01	Carburetor packing	1
3	QJ153FM-0000041	Clip	2
4	QJ182QDP.10-02	Hose ϕ 4.5x ϕ 8.5x190	1
5	QJ182QDP.08.01-02	Cable Clamp	2

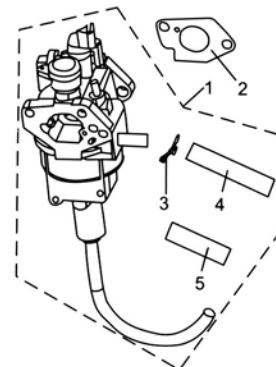

PARTS LIST AND DIAGRAMS

Air Cleaner Assembly

NO.	PARTS NO.	DESCRIPTION	QTY
1	QJ182FPH-15.04B	Air Cleaner Assy	1
2	QJ182QDP.11-6	Clip, Fixup	2
3	QJ182QDP.11-7	Clip, Fixup	2
4	QJ182fph-15.04-01	Air Cleaner Cover	1
5	GB/T6177-2000	NUT M5	6
6	QJ182QDP.11-9	Core, Filtrate	1
7	QJ182QDP.11-3	Hole Board	1
8	QJ182QDP.11-4	Seal Gasket,	1
9	QJ182QDP.11-5	Below Shell, Air Cleaner	1
10	QJ182FPH-2.01.02	Air Cleaner Support	1
11	GB/T6177-2000	NUT M6	1

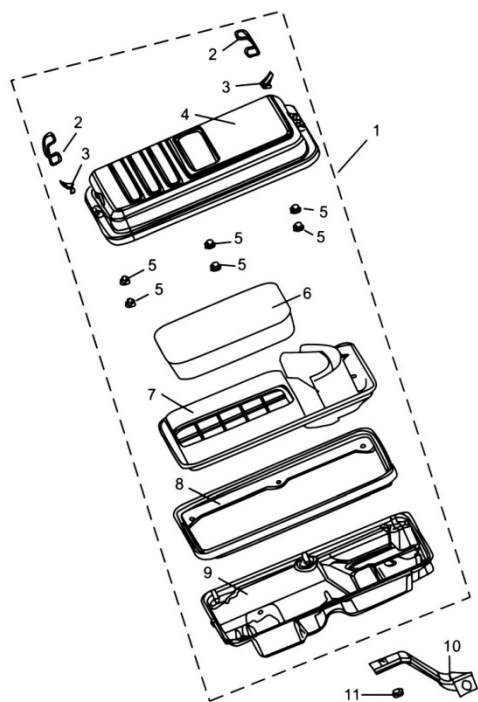

Carburetor Assembly

NO.	PARTS NO.	DESCRIPTION	QTY
1	QJ182QDP.02.02-03	Breath Tube	1
2	QJ182QDP.02.02-04	Rubber galosh	1
3	QJ182QDP.10.02	Choke vavle variable pump comp.	1
4	QJ182QDP.10.02-03	Clip	1
5	QJ182QDP.10.02.01-01	Clip	4
6	QJ182QDP.10.02.01-02	Hose 4x 8x135	2
7	QJ182QDP.10.02.01.01	Valve	1
8	QJ188FPH.02-08	Bakelite Washer	1
9	QJ182QDP.10.02-04	Rubber galosh II	1
10	QJ182QDP.10.02.01	Valve Assy	1
11	QJ182QDP.10.02-01	Choke vavle Pull pole	1
12	QJ182QDP.10.02-02	Rubber galosh	1
13	QJ182QDP.10.02.02	Breath body Assy	1
14	QJ182QDP.11-1	Air cleaner Packing	2
15	QJ182FPH-2.07-01	Pull pole	1

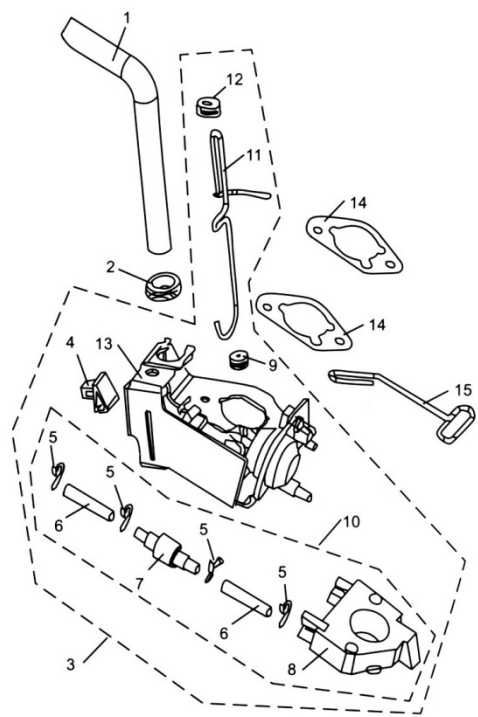

PARTS LIST AND DIAGRAMS

Generator

NO.	CODE	DESCRIPTION	QTY
1	GB/T5787-86	Bolt M5*12	7
2	QJ6500.03-04	Right Cover	1
3	QJ6000.03.04	AVR	1
4	GB/T5780-2000	Bolt M5*20	3
5	QJ6500.03-03	Connector	1
6	GB/T5789-86	Bolt M5*12	1
7	QJ2500.03-04	Rectifier KBPC2506	1
8	GB/T5789-86	Bolt M10*260*1.25	1
9	QJ6000.03.01	Brush Equipment	1
10	QJ6000.03-02	Motor Shell	1
11	QJ7500.03.01	Rotor Assy	1
12	QJ7500B.02-01	Motor cover	1
13	QJ6000.03.03.01	BEARING, needle	1
14	QJ6000.03.03-06	Carbon Brush Ring	1
15	QJ7500.03.02	Stator	1
16	QJ6000.03.03-01	Impeller	1
17	GB/T95-2002	Washer	3
18	GB/T93-87	Spring Washer	3
19	GB/T818-2000	Bolt M5*12	3
20	GB/T5789-86	Bolt M6*170	4

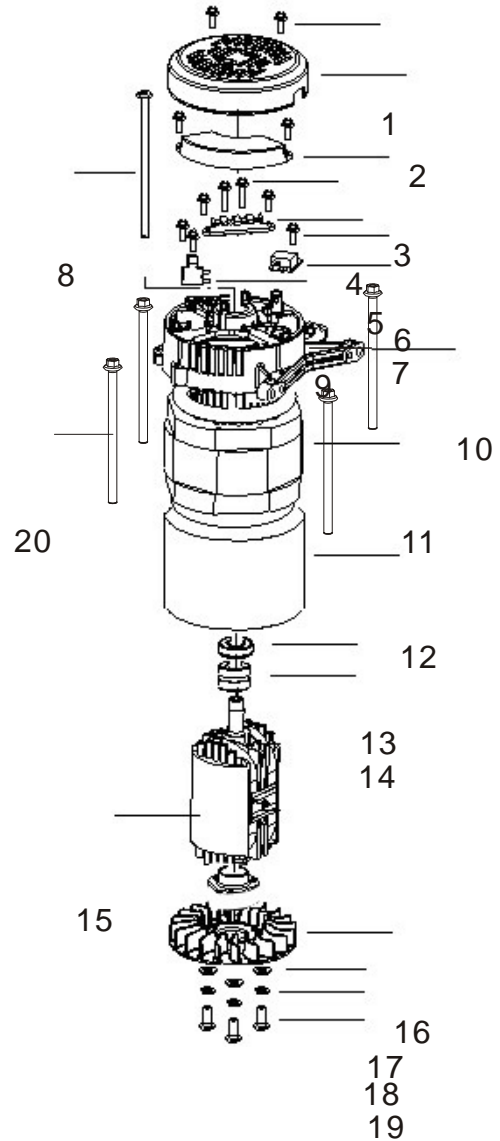

Gas Tank Assembly

NO.	CODE	DESCRIPTION	QTY
1	KE6600.01.01	Fuel Tank Comp	1
2	QJ950.01-02	Filtering Net	1
3	QJ2600.01.05	Sump Cover Subassembly	1
4	GB/T819-2000	Screw M5*10	2
5	QJ6000.01.03	Sender Unit	1
6	GB/T5789-86	Bolt M6*20	4
7	GB/T96.1-2002	Washer	4
8	QJ2600.01-02	Fuel Tank Rubber Hose	4
9	QJ2600.01-01	Fuel Tank Rubber	4
10	QJ6000.01.02	Fuel Valve	1

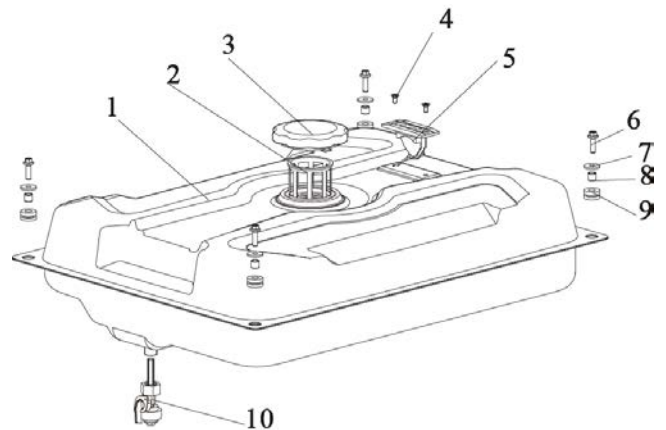

PARTS LIST AND DIAGRAMS

Control Panel Assembly

NO.	CODE	DESCRIPTION	QTY.
1	KE6600.02.01	Bottom Shell	1
2	KE9000E.02.03A	Panel	1
3	KE9000E.02.02A	Cable	1
4	QJ6000.02-04	Bellows	1
5	QJ2600.02.03	Oil Light	1
6	QJ6500B.02.02	Engine Swith	1
7	QJ6500.02.09	Rectifier Assy. 4A	1
8	GB/T6177-2000	Nut M4	10
9	KE9000E.02.04	Mult. Digital Meter	1
10	QJ3500.02.03A	Circuit Breaker 25A	2
11	QJ3200TB.01.05	Circuit Breaker 20A	2
12	QJ6500.02-02	Flared Sheath	1
13	QJ3200.01.04	Double Socket	2
14	QJ6500D.01.02	4-Pole Socket	1
15	QJ6500D.01.05	3-Pole Socket	1
16	GB/T5787-86	Bolt M6*16	1
17	GB/T6170-2000	Nut M6	2
18	GB/T923-85	Nut M6	1
19	QJ900.05.03	V Socket	1
20	GB/T818-2000	Screw M4*12	10
21	GB/T845-1985	Screw ST4X10	8
22	QJ6500.02.05	DC Protector	1
23	GB/T818-2000	Screw M6*14	4

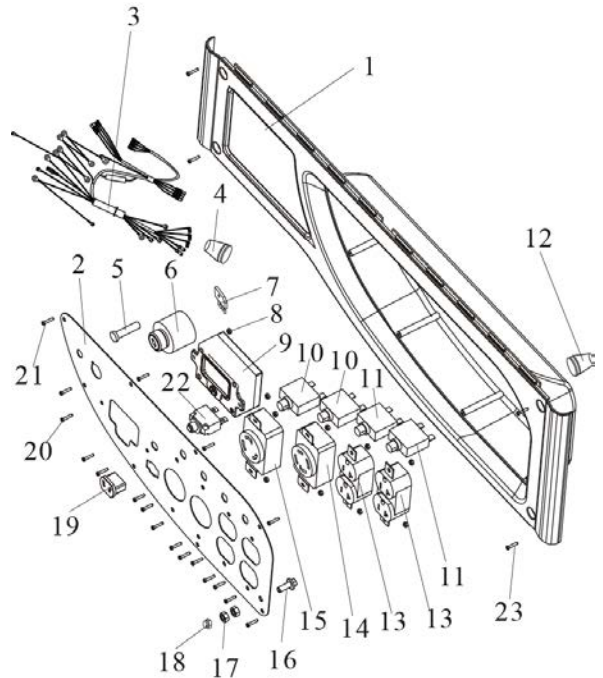

Muffler Assembly

NO.	CODE	DESCRIPTION	QTY.
1	QJ7500.07.01	Muffler	1
2	QJ6800.05-01	Muffler Cover	1
3	CODE	Hexagonal Socket Head Cap Screw	2
4	GB/T93-87	Spring Washer	2
5	QJ6000.07-02	Muffler Washer	1

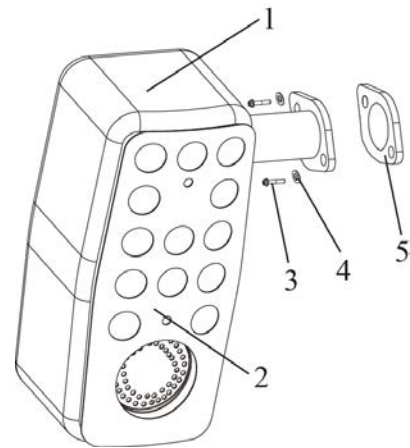

Motor Shield Assembly

NO.	CODE	DESCRIPTION	QTY.
1	QJ6500.03-05	Motor shield	1

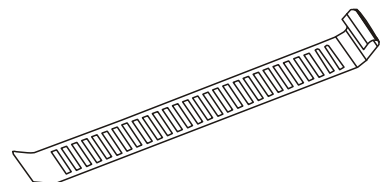

PARTS LIST AND DIAGRAMS

Frame Assembly

NO.	PARTS NO.	DESCRIPTION	QTY
1	QJ125T-3B	Handrail Jacket	2
2	QJ6500D.04-01A	Handrail	2
3	GB/T6177-2000	Nut M6	2
4	GB/T5789-1986	Bolt M6*40	2
5	GB/T5789-1986	Bolt M6*10	8
6	KE6600.01.05A	Fuel Tank Protecting Plate	2
7	KE7500E.06.01	Frame Jointing Assy	1
8	GB/T5789-1986	Bolt M6*12	2
9	QJ6000.08.03	Shockproof Small Mounting Feet	2
10	KE3500DE.04.02B	Accumulator Bandage	2
11	KE9000E.09.01	Hollow Rubber Wheels	2
12	KE9000E.09.01	Wheel Axis Bolt M12*90	2
13	GB/T95-2002	Washer 13	2
14	QJ6500B.02.02	Battery Box	1
15	GB/T6177-2000	Nut M8	4
16	KE7500E.04.01	Crutch	2
17	QJ6800.06-01	Crutch Jacket	2
18	QJ3200TB.02-01	End Cap	2
19	GB/T5780-2000	Bolt M8*16	4
20	QJ6000.08.02	Shockproof Big Mounting Feet	2

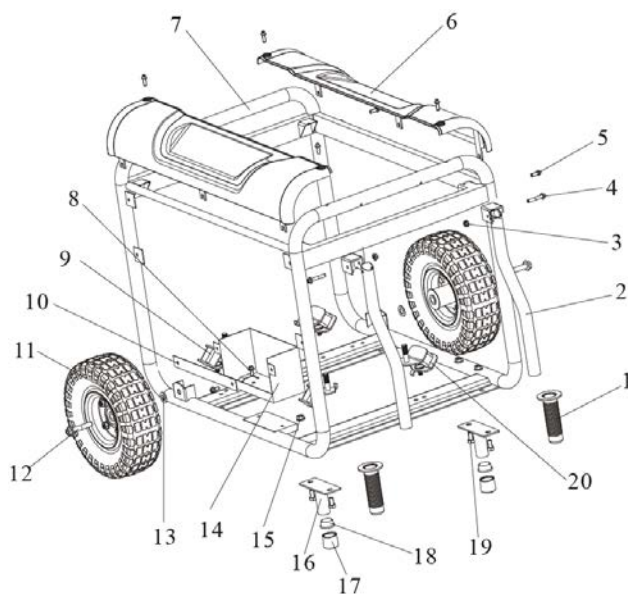

Exhalation System

NO	PART NO	DESCRIPTION	QTY
1	QJ6500D.07.01	Carbon Canister	1
2	QJ2900.08-01	Clamp	4
3	QJ2900.08-02	Rubber Pipe 1 $\phi 5^* \phi 8^* 45$	1
4	QJ2900.08.02	Check Valve	1
5	QJ6500D.07-01	Rubber Pipe 2 $\phi 5^* \phi 8^* 480$	1
6	QJ6500D.07-02	Rubber Pipe 3 $\phi 8^* \phi 12^* 140$	1
7	QJ2900.08-05	Clamp	2

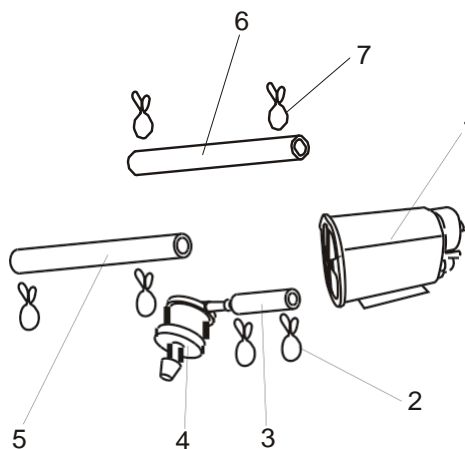

PARTS LIST AND DIAGRAMS

LPG Regulator

NO	PARTNO	DESCRIPTION	QTY
1	QJ7500LGG.10.01	Regulator(LPG)	1
2	QJ7500LGG.10.02	High Pressure Pipe	1
3	QJ7500LGG.10-01	Regulator Bracket	1

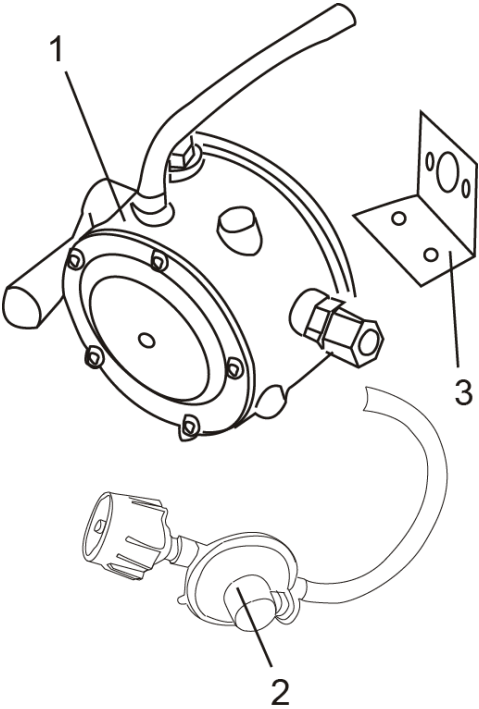

Owner's Manual

Troubleshooting

Problem	Cause	Solution
Generator will not start	No Fuel	Fill with fuel
	Faulty spark plug	Replace spark plug
	Unit loaded during start up	Remove load from unit
Generator will not start; Generator starts but runs roughly	Low oil level	Fill crankcase to the proper level Place generator on a flat, level surface before restarting
	Choke in the wrong position.	Adjust choke.
	Spark plug wire loose	Attach wire to spark plug
Generator shuts down during operation	Out of fuel	Fill fuel tank
	Low oil level	Fill crankcase to the proper level. Place generator on a flat, level surface before starting
Generator cannot supply enough power or overheating	Generator is overloaded	Review load and adjust. See "Power Management"
	Insufficient ventilation	Check for air restriction. Move to a well ventilated area
No AC output	Cable not properly connected	Check all connections
	Connected device is defective	Replace defective device
	Circuit breaker is open	Reset circuit breaker
	Capacitor defective	Replace capacitor. Contact Smarter Tools
	Faulty brush assembly	Replace brush assembly Contact Smarter Tools
	Faulty AVR	Replace AVR Contact Smarter Tools
	Loose wiring	Inspect and tighten wiring connections
Other	Contact Smarter Tools	
Generator gallops	Engine governor defective	Contact Smarter Tools
Repeated circuit breaker tripping	Overload	Review load and adjust. See "Power Management"
	Faulty cords or device	Check for damaged, bare or frayed wires. Replace defective device

Owner's Manual

Warranty Identification

To assist in accurately determining whether your Smarter Tools product is still covered by manufacturer's warranty and to identify your product properly should you need to contact customer service an Hour Meter and Identification Plate have been installed.

Hour Meter

The product's Hour Meter can be found on the front control panel to the right of the power switch .



Note: The Hour Meter is tied directly to the product warranty. Attempting to disable or otherwise tamper with the Hour Meter will VOID the manufacturer's warranty.

Identification Plate

The product's Identification Plate can be found on the lower-frame cross arm just behind the air filter. See figure below.

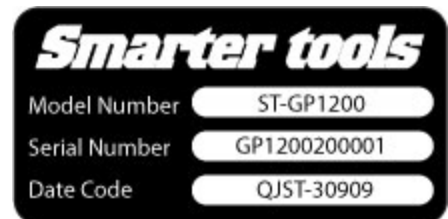
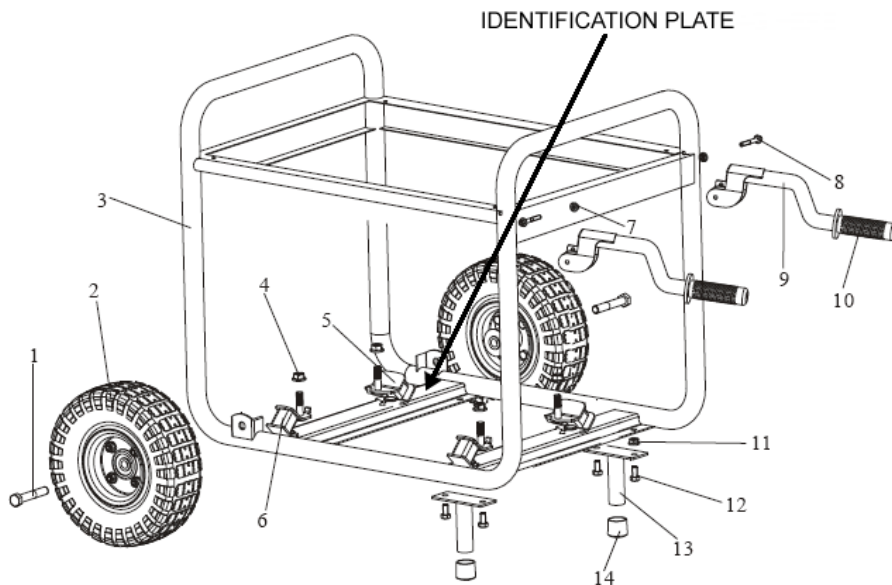

Note: Properly registering your product with Smarter Tools is the only way to ensure that your product will be eligible for warranty replacement or repair should an unforeseen event cause the Identification Plate to be unreadable. Register your product online at www.usesmartertools.com/register or by mailing in your warranty registration card within 14 days of product purchase.

LIMITED WARRANTY

Effective April 1, 2012. Replaces all undated warranties and all warranties dated before April 1, 2012

Warranty Qualifications

Smarter Tools will register this warranty upon receipt of your Warranty Registration Card and a copy of your sales receipt from one of Smarter Tools' retail locations as proof of purchase.

Please submit your warranty registration and your proof of purchase within fourteen (14) days of the date of purchase.

Repair/Replacement Warranty

Smarter Tools warrants to the original purchaser that the mechanical and electrical components will be free of defects in material and workmanship for a period of two (2) years or 60 hours (measured by the factory installed hour meter) from the original date of purchase (90 days or 60 hours for commercial & industrial use). Transportation charges on product submitted for repair or replacement under this warranty are the sole responsibility of the purchaser. This workmanship for a period of warranty only applies to the original purchaser and is not transferable.

Do not return the unit to the place of purchase

Contact Smarter Tools' Customer Service and Smarter Tools will troubleshoot any issue via phone or e-mail. If the problem is not corrected by this method, Smarter Tools will, at its option, authorize evaluation, repair or replacement of the defective part or component at a Smarter Tools Service Center. Smarter Tools will provide you with a case number for warranty service. Please keep it for future reference. Repairs or replacements without prior authorization, or at an unauthorized repair facility, will not be covered.

Warranty Exclusions

This warranty does not cover the following repairs and equipment:

Normal Wear

Generators need periodic parts and service to perform well. This warranty does not cover repair when normal use has exhausted the life of a part or the equipment as a whole.

Installation, Use and Maintenance

This warranty will not apply to parts and/or labor if this generator is deemed to have been misused, neglected, involved in an accident, abused, loaded beyond the generator's limits, modified, installed improperly or connected incorrectly to any electrical component. Normal maintenance such as spark plugs, air filters, adjustments, fuel system cleaning and obstruction due to buildup is not covered by this warranty.

Other Exclusions

This warranty excludes:

- Merchandise sold as reconditioned, used as rental equipment, or floor/display models sold without packaging and/or missing parts or components.
- Repair and transportation costs of merchandise determined not to be defective.
- Cosmetic defects such as paint, decals, etc.
- Wear items such as filter elements, o-rings, etc.
- Accessory parts such as starting batteries, and storage covers.
- Failures due to acts of God and other forces of nature beyond the manufacturer's control.
- Problems caused by parts that are not original Smarter Tools parts.

This warranty does not apply to generators used for prime power in place of a utility.

Limits of Implied Warranty and Consequential Damage

Smarter Tools disclaims any obligation to cover any loss of time, use of this product, freight, or any incidental or consequential claim by anyone from using this generator. THIS WARRANTY IS IN LIEU OF ALL OTHER WARRANTIES, EXPRESS OR IMPLIED, INCLUDING WARRANTIES OF MERCHANTABILITY OR FITNESS FOR A PARTICULAR PURPOSE.

A unit provided as an exchange will be subject to the warranty of the original unit. The length of the warranty governing the exchanged unit will remain calculated by reference to the purchase date of the original unit.

This warranty gives you certain legal rights which may change from state to state. Your state may also have other rights you may be entitled to that are not listed within this warranty.

Some states do not allow the exclusion, so it may not apply to you.

Contact us at:

Smarter Tools Customer Service

12195 Harley Club Drive
Ashland, VA 23005

(888)241-8498

customerservice@usesmartertools.com

