

PARTS REFERENCE

EXPLODED VIEW

TOOLS REQUIRED FOR ASSEMBLY:

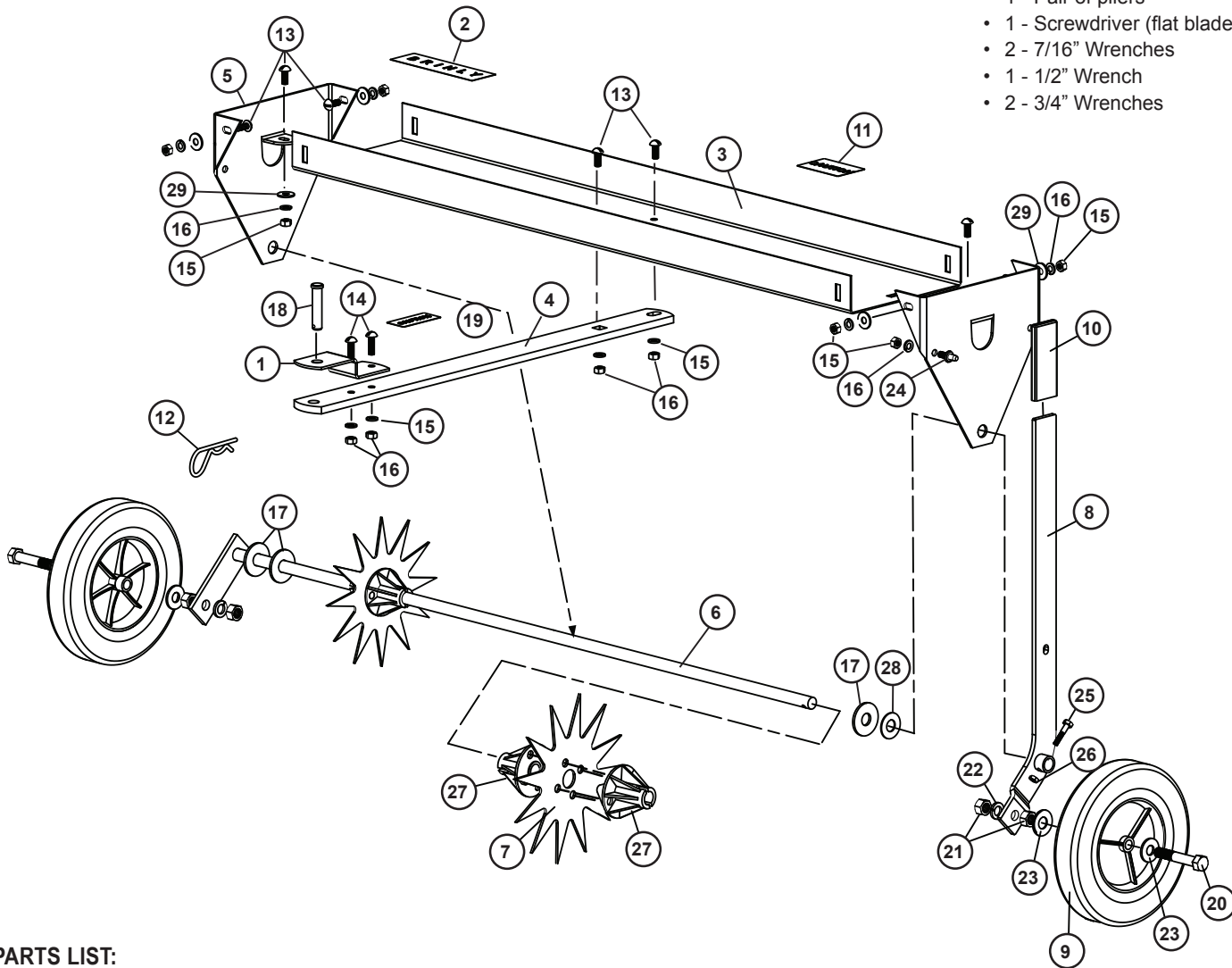

- 1 - Pair of work gloves
- 1 - Pair of pliers
- 1 - Screwdriver (flat blade)
- 2 - 7/16" Wrenches
- 1 - 1/2" Wrench
- 2 - 3/4" Wrenches

PARTS LIST:

REF	PART NO.	DESCRIPTION	QTY.	REF	PART NO.	DESCRIPTION	QTY.
1.	R-821-10	Drawbar Clevis	1	15.	30M1000P	Hex Nut, 5/16"	11
2.	B-5925	Logo Decal	1	16.	40M1000P	Lock Washer, 5/16"	11
3.	B-5453-10	Tray	1	17.	B-5456	Flat Washer, 5/8" (thick)	5
4.	B-3593-10	Drawbar	1	18.	B-3861	Drawbar Pin	1
5.	B-4892-10	End Panel	2	19.	B-3922	Caution Decal	1
6.	B-5832-10	Axle Assembly	1	20.	1M1648P	Hex Bolt, 1/2"x3"	2
7.	B-5423	Tine	11	21.	30M1600P	Hex Nut, 1/2"	4
8.	B-4888-10	Handle Assembly	1	22.	40M1600P	Lock Washer, 1/2"	2
9.	R-891	Wheel	2	23.	45M1717P	Flat Washer, 1/2"	4
10.	B-4867	Handle Grip	1	24.	B-3307-S	Transport Lock Pin	1
11.	R-1946	Caution Decal	1	25.	2M0820P	Hex Bolt, 1/4"x1-1/4"	1
12.	D-146P	Hairpin Cotter	1	26.	B-1673P	Hex Lock Nut, 1/4"	1
13.	20M1012P	Round Head Screw, 5/16"x3/4"	8	27.	B-5425	Spacer/Bearing, Tube	22
14.	20M1016P	Round Head Screw, 5/16"x1"	2	28.	B-4768	Flat Washer, 5/8" (thin)	2
				29.	45M1111P	Flat Washer, 5/16"	6