



# Tomahawk *PMF18* Power Concrete Saw

## Operation and Instruction Manual



# Table of Contents

<b>1. Safety Information</b>	3
1.1 Safety Precautions	3
1.2 Operating Safety	4
1.3 Operator Safety while using Internal Combustion Engines	6
1.4 Label Locations	6
1.5 Safety and Operating Labels	7
<b>2. Operation</b>	8
2.1 Controls	8
2.2 Operating Principle	9
2.3 Delivery Checks	9
2.4 Installing Blade	9
2.5 Before Starting	9
2.6 To Start	10
2.7 To Stop	11
2.8 To Start Cutting	11
2.9 Cutting	12
2.10 Belts & Pulleys	12
2.11 Dry Cutting	13
2.12 Parking Brake	13
2.13 Lifting	14
<b>3. Maintenance</b>	14
3.1 Periodic Maintenance Schedule	14
3.2 Lubrication	15
3.3 Spark Plug	15
3.4 Air Cleaner	15
3.5 Transporting	15
3.6 Troubleshooting	16
<b>4. Technical Data</b>	19
<b>Warranty</b>	19
<b>Maintenance Record</b>	20

This manual provides information and procedures to safely operate and maintain this model. For your own safety and protection from injury, carefully read, understand and observe the safety instructions described in this manual.

Keep this manual or a copy of it with the machine. If you lose this manual or need an additional copy, please contact Tomahawk Power LLC or visit [www.tomahawk-power.com](http://www.tomahawk-power.com). This machine is built with user safety in mind; however, it can present hazards if improperly operated and serviced. Follow operating instructions carefully. If you have questions about operating or servicing this equipment, please contact Tomahawk Power.

The information contained in this manual is based on machines in production at the time of publication. Tomahawk Power reserves the right to change any portion of this information without notice. No part of this publication may be reproduced in any form or by any means, electronic or mechanical, including photocopying, without express written permission from Tomahawk Power.

Any type of reproduction or distribution not authorized by Tomahawk Power represents an infringement of valid copyrights and will be prosecuted. We expressly reserve the right to make technical modifications, even without due notice, which aim at improving our machines or their safety standards.

## 1. SAFETY INFORMATION

### 1.1 Safety Precautions

This manual contains DANGER, WARNING, CAUTION, and NOTE callouts which must be followed to reduce the possibility of personal injury, damage to the equipment, or improper service.



This is the safety alert symbol. It is used to alert you to potential personal injury hazards. Obey all safety messages that follow this symbol to avoid possible injury or death.



DANGER indicates an imminently hazardous situation which, if not avoided, will result in death or serious injury.



WARNING indicates a potentially hazardous situation which, if not avoided, could result in death or serious injury.



CAUTION indicates a potentially hazardous situation which, if not avoided, may result in minor or moderate injury.

**CAUTION:** Used without the safety alert symbol, CAUTION indicates a potentially hazardous situation which, if not avoided, may result in property damage.

## **1.2 Operating Safety**

**WARNING:** Failure to follow instructions in this manual may lead to serious injury or even death! This machine is to be operated by trained and qualified personnel only! This machine is for industrial use only. The following safety guidelines should always be used when operating this concrete floor saw.

### **1.2.1 General Safety**

- DO NOT modify the machine without the prior consent of the manufacturer. We do not assume responsibility for any accident due to equipment modification.
- NEVER operate the machine for any purpose for which it is not intended.
- NEVER allow anyone to operate the machine without proper training and under 18 years old. Those who operate the machine must be familiar with the risks and hazards associated with it.
- ALWAYS operate the machine with all safety devices and guards in place and in working order.
- DO NOT wear loose fitting clothing that might get caught in the machine.
- DO NOT operate the machine in poorly ventilated spaces. There is a risk of carbon monoxide poisoning.
- ALWAYS wear eye protection, ear protection and steel-toed boots during work.
- DO NOT use the machine if you are experiencing discomfort, cramps, pain, or work under the influence of drugs or alcohol.
- DO NOT use the machine near flammable material or in explosive atmosphere. The exhaust pipe can become very hot during operation. Sparks may be emitted from it, and ignite flammable material.
- ALWAYS check that all controls are functioning properly immediately after start-up. DO NOT operate the machine unless all controls operate correctly.
- NEVER operate the machine with the fuel cap loose or missing.
- NEVER touch the engine, exhaust system, muffler and cylinder. They are extremely hot during operation.
- DO NOT touch the V-belt and rotating parts during operation.
- Block the machine when leaving or operating on slopes.

### **1.2.2 Diamond Blade Safety**

- ALWAYS use the appropriate diamond blade for cutting.
- ALWAYS check the diamond blade before using. The blade should exhibit no cracks, dings, or flaws in the steel centered core and/or rim.

- Examine blade flanges for damage, excessive wear and cleanliness before mounting blade. Blade should fit snugly on the shaft and against the inside/outside blade flanges.
- Ensure that the blade is marked with an operating speed greater than the blade shaft speed of the saw.
- Only cut material that is specified by the diamond blade. Read the specifications of the diamond blade to ensure the proper tool has been matched to the material being cut.
- ALWAYS keep blade guards in place. Exposure of the diamond blade must not exceed 180 degrees.
- Ensure that the diamond blade does not come into contact with ground or surface during transportation. DO NOT drop the diamond blade on ground or surface.
- The engine governor is designed to permit maximum engine speed in a no-load condition. Speeds that exceed this limit may cause the diamond blade to exceed the maximum safe allowable speed.
- Ensure that the blade is mounted for proper operating direction.

### **1.2.3 Transport Safety**

- Use the lifting bail and appropriate lifting equipment to ensure the safe movement of the saw.
- DO NOT use the handle bars and/or front pointer as lifting points.
- NEVER tow the saw behind a vehicle.
- Ensure that both pointer bars are positioned appropriately to minimize their exposure during transportation.
- Engines tipped to extreme angles may cause oil to move into the cylinder head making the engine difficult to start.
- NEVER transport the machine with the blade mounted.

### **1.2.4 Emergency**







ALWAYS know the location of the nearest fire extinguisher and first aid kit. Know the location of the nearest telephone. Also know the phone numbers of the nearest ambulance, doctor and fire department. This information will be invaluable in the case of an emergency.

### **1.2.5 Maintenance Safety**

- NEVER lubricate components or attempt service on a running machine.



## 1.5 Safety and Operating Labels

LABEL	MEANING
	<p><b>DANGER!</b> Engine emits carbon monoxide; operate only in well-ventilated areas. Read the Operator's Manual for machine information. No sparks, flames, or burning objects near the machine. Shut off the engine before refueling. Use only clean, filtered, unleaded gasoline.</p>
	<p><b>WARNING!</b> Always wear hearing and eye protection when operating this machine.</p>
	<p><b>CAUTION!</b> Read and understand the supplied Operator's Manual before operating the machine. Failure to do so increase the risk of injury to yourself or others.</p>
	<p><b>CAUTION!</b> Lifting point.</p>
	<p><b>WARNING!</b> Injuries to hand may be caused if caught in moving belt. Always replace belt guard.</p>
	<p><b>WARNING!</b> Hot surface!</p>
	<p><b>WARNING!</b> Keep all hands and feet away from the moving saw blade.</p>



**WARNING!**



A nameplate listing the model number and serial number is attached to each unit. Please record the information found on this plate so it will be available if the nameplate is lost or damaged. When requesting service information, the serial number should be specified in the unit.

## 2 OPERATION

### 2.1 Controls

**A. Refueling**

**B. Throttle Control**

**C. Water Tank Filling**

**D. Handle for Operating**

**E. Handle for Blade Height Adjustment**

**F. Trolley Wheel**

**G. Splash Guard**

**H. Blade Guard**

**I. Pointer Wheel**

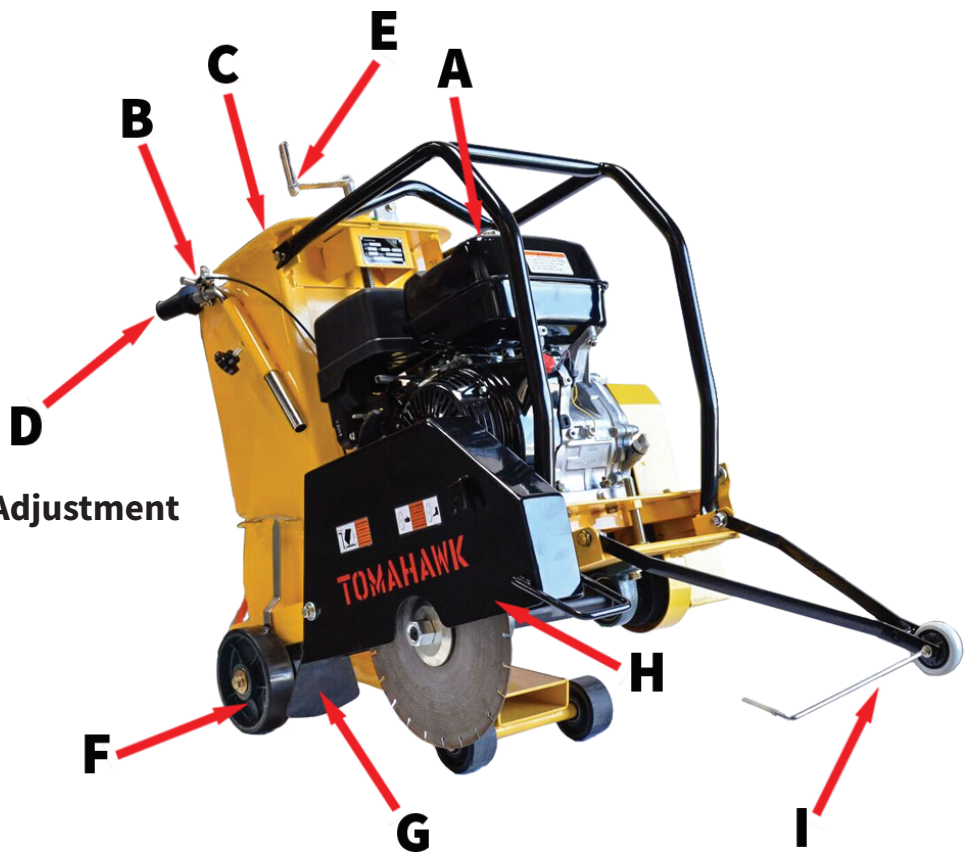



## **2.2 Operating Principle**

The following instructions were compiled to provide you information on how to obtain long and trouble free use of the machine. Periodic maintenance of the machine is essential. Read the manual carefully and thoroughly familiarize yourself with the machine and all it's functions. Failure to do so may injure yourself or someone else.

## **2.3 Delivery Checks**

Upon receiving new machine and before putting it into service.

- Read the operation manual completely- it could save a great deal of unnecessary headaches.
- Read the engine manual supplied.
- Check the general condition of the machine – has it been damaged during delivery?
- Check engine oil level.
- Check fuel level.

Recommended lubricants are detailed in the Care and Maintenance section.

## **2.4 Installing Blade**

- Be certain that the spark plug is disconnected and the saw is unplugged.
- Remove the blade shaft nut, and take off the outside blade shaft flange.
- Clean off any foreign particles on the clamping surfaces of flanges and on the mounting surface of the blade.
- Place the blade on the blade shaft, lining up the offset drive pin in the blade with the drive pin in the mounting collar (if the pin system is available on the machine). If your blade has a directional rotational arrow, position arrow for down cut (diamond tail trailing for down cut).
- Replace the outside blade shaft flange on the blade shaft. The drive pin on the inside collar must project through the drive hole in the blade and into the outside collar (if the pin system is available on the machine).
- Tighten the blade shaft nut securely against the star washer and the outside flange, using the wrench supplied.
- Reconnect the spark plug or (with switch “off”) plug in the electric supply cord.
- The saw can cut on the right and left hand, please replace the blade as required.

## **2.5 Before Starting**

Before starting the machine, check the following items:

- All handles are free from grease, oil, and dirt.
- All control levers are in the neutral position.
- All bolted joints are tightened.
- Fuel level.

- Water tank level.
- Oil level in the engine.
- Air filter maintenance indicator.
- Check arbors and flanges are clean and undamaged.
- If operating in wet-cutting, check water jets for adequate flow.
- Align pointer with saw blade.

**NOTICE:** The warranties are VOID if the machine is run without oil.

## 2.6 To Start

Before starting the machine, operator must know the location and function of all controls.

### 2.6.1 To Start - Gas Engine

1. Do not actuate starter for more than 20 seconds at a time. If engine does not start, wait 1 minute before repeating attempt. If engine does not start after two attempts, trace the cause according to Diagnosis Chart.
2. Key always in on (1st) position when engine is running. Make sure that all the warning lights are off when the engine is running. For engines with starting panel equipped with engine protection, make sure the OK light is ON.



1st position - Warning light ON



2nd position - Starting

3. After starting, idle speed for a few minutes according to table:

Temperature	Time
δ - 68° F	5'
- 4° F / 14 ° F	2'
14° F / 23 ° F	1'

### **2.6.2 To Start - Petrol Engine**

1. Open the fuel tap by moving the fuel ON/OFF lever fully to the right.
2. If starting the engine from cold, set the choke ON by moving the choke lever fully to the left. If restarting a warm engine, the choke is usually not required. However, if the engine has cooled, partial choke may be required.
3. Turn the engine ON/OFF switch clockwise to “1” position.
4. Set the throttle to the idle position by moving the throttle lever fully to the right. Do not start the engine on full throttle, as the compactor will vibrate as soon as the engine starts.
5. Taking a firm hold of the control handle with one hand, grasp the recoil starter handle with the other. Pull the recoil starter until engine resistance is felt, then let starter return.
6. Taking care not to pull the starter’s cord fully out, pull the starter handle briskly.
7. Repeat until the engine fires.
8. Once the engine fires gradually, set the choke lever to the OFF position by moving it to the right.
9. If the engine fails to fire after several attempts, follow the trouble-shooting guide on page 9.
10. To stop the engine, set the throttle to idle and turn the engine ON /OFF switch counterclockwise to the “0” position.
11. Turn the fuel off.

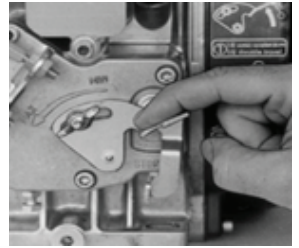

### **2.7 To Stop**

1. Before stopping, idle speed for a few minutes.
2. Leave and/or key in stopping position.
3. Close the fuel valve.

### **2.8 To Start Cutting**

1. Start engine and let engine warm up. All cutting is done at full throttle.
2. Align blade and saw with cut. If wet cutting, open water valve and turn water safety switch ON.
3. Step on the left side of PEDAL until a “click” is heard, then turn on the WHEEL HANDLE on the top of the machine to remove the equipment forward and reverse, step down on the right side of PEDAL to change to the “push” driving system.

4. Lower blade into cut slowly.
5. Cut as fast as blade will allow. If blade misaligns from cut, reduce forward speed or depth of cut.
6. Use only enough side pressure on saw handles to follow cutting line.

## **2.9 Cutting**

Lower the blade into concrete to the required depth by turning the tilt crank counter-clockwise. Ease the saw slowly forward. Slow forward pressure if the saw begins to stall.

**Note:** For deeper cuts (4 inches/102mm or more), several cuts should be made in incremental steps of 1-1/2 inch (38mm) to 2 inches (51mm) until the desired depth is reached.

Push the saw steadily forward using the front pointer as a guide. Exert enough forward pressure so that the engine/motor begins to labor, but does not slow down. If the saw begins to stall, slow forward movement until full RPM is restored to the blade. If saw stalls, raise the blade out of the cut before restarting. Avoid excessive side pressure or twisting of the blade in the cut.

## **2.10 Belts & Pulleys**

**Never adjust the V-belts and pulleys when engine is running.**

1. The best tension for a v-belt drive is the lowest tension at which the belts will not slip under full load.
2. Increase tension until the belts are snug in the grooves. Run the drive for about five (5) minutes to “seat” the belts. Impose the peak load. If the belts slip, tighten them until they no longer slip at peak load. Most new belts will need additional tensioning after seating.
3. Remember, too much tension shortens belt and bearing life.
4. Check the belt tension frequently during the first day of operation. Check the belt tension periodically thereafter and make any necessary adjustments.
5. The two most common causes of sheave misalignment are:
  - a) The engine drive shaft and the blade shaft are not parallel.
  - b) The pulleys are not located properly on the shafts.

6. To check alignment, use a steel straight edge. See Figure 1.

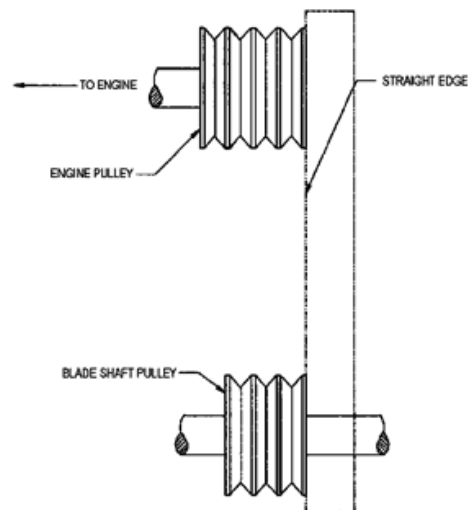

Figure 1

7. Line up the straight edge along the outside face of both pulleys shown in the drawing. All pulleys have (2) set screws in the bottom of their grooves. Set screws require thread locking lock title.

8. Misalignment will show up as a gap between the pulley face and straight edge. Make sure there is clearance between arbor pulley and saw base on both sides.

### 2.11 Dry Cutting

- Never operate any saw without safety guards in place.
- Do not exceed maximum operating speed established for blade diameter.
- Do not force blade into material: allow blade to cut at its own speed.
- Do not make long continuous cuts. Never dry cut for more than 30 seconds at a time. Allow blade to cool.
- Do not cut or grind with side of blade or cut a curve or radius. Do not cut dry with blades recommended for wet cutting.
- Do not operate saw with blade diameter larger than machine's capacity.

### 2.12 Parking Brake

The parking brake is used to ensure that the machine will not roll when not in use. ALWAYS park the machine on the most level ground.

1. Use the parking brake.
2. Turn off the engine and pull out the ignition key.

## 2.13 Lifting

1. NEVER tow the machine.
2. ONLY use steel ropes or chains for lifting.
3. Make sure that the ropes or chains have enough lifting capacity to hold the machine (see the information on the machine plate for weight).
4. ONLY lift the machine by the hook on the frame.
5. DO NOT stand or walk under a lifted machine.

## 3. Maintenance

### 3.1 Periodic Maintenance Schedule

	Daily	Every 20 hours	Every 50 hours	Every 100 hours	Every 300 hours
Check fuel level	●				
Check engine oil level	●				
Inspect air filter. Replace as needed.	●				
Check the cutting blade for damage and tightness	●				
Check the direction of rotation arrow of the cutting blade	●				
Replace the engine oil		●			
Clean air filter, change if necessary			●		
Check the belt for tension and wear			●		
Clean the fuel filter				●	
Change engine oil				●	
Clean spark plug				●	
Check idle setting					●
Change spark plug					●
Change air filter					●

### 3.2 Lubrication

The long life and successful operation of any machinery is dependent on frequent and thorough lubrication. Before using the machine, always check the oil and use proper oil with the correct type and grade as recommended.

**NOTICE:** DO NOT mix types of engine oil and DO NOT overfill the oil. Damage to the machine may occur if oils are mixed or overfilled. See Technical Data for oil quantity and type.

### 3.3 Spark Plug

Check and clean spark plugs regularly. A fouled, dirty spark plug may cause hard starting and poor engine performance. Set spark plug gap to recommended clearance. Refer to engine manual.



The muffler and engine cylinder become very hot during operation and remain hot for a while after stopping the engine. Allow engine to cool before removing spark plug.

**NOTICE:** A loose spark plug can become very hot and may cause engine damage.



### 3.4 Air Filter

Maintaining a clean engine will extend engine life. Keep air filter clean at all times. Clean air filter using the recommended solvent daily. See engine manual for proper cleaning procedure. Let the filter dry before reinstalling.





### 3.5 Transporting



1. Before transporting the machine, ALWAYS turn off the engine and pull out the key from the machine.
2. Make sure lifting device has enough capacity to hold machine (see identification plate on machine for weight).
3. Use lifting point when lifting the machine.
4. Optional trolley wheel is used for short distance transportation.

### 3.6 Troubleshooting

SYMPTOM	POSSIBLE CAUSES	SOLUTION
<p>Uneven segment wear</p> 	<p>(Wet cutting) Insufficient water (Usually on one side of blade) Equipment defects also can cause the segments to wear unevenly.</p> <p>Saw head is misaligned.</p>	<p>Flush water system. Check flow to both sides of blade. Replace bad bearings, worn arbor shaft or misalignment to spindle.</p> <p>Check alignment for squareness, both vertically and horizontally, of the saw blade.</p>
<p>Segment cracks</p> 	<p>Blade is too hard for material being cut.</p>	<p>Use a blade with a softer bond/matrix.</p>
<p>Segment loss</p> 	<ul style="list-style-type: none"> <li>-Blade overheats because of lack of coolant (water or air).</li> <li>-Core is worn from undercutting.</li> <li>-Defective collars/flanges set blade out of alignment.</li> <li>-Blade is too hard for material being cut.</li> <li>-Blade is cutting out of round, causing a pounding motion. Improper blade tension.</li> </ul>	<ul style="list-style-type: none"> <li>-(Wet cutting) Check water lines. Make sure flow is adequate on both sides of blade and there are no blockages.</li> <li>-Use sufficient water to flush out the cut.</li> <li>-(Dry Cutting) Run blade free of cut periodically to air cool.</li> <li>-Clean collars/flanges or replace if they are under recommended diameter.</li> <li>-Use proper blade specification for material being cut.</li> <li>-Replace worn bearings; realign blade shaft or replace worn blade mounting arbor.</li> <li>-When ordering blades, match shaft speed of saw.</li> <li>-Check spindle speed to ensure blade is running at correct RPM. Avoid twisting or turning blade in the cut.</li> </ul>



SYMPTOM	POSSIBLE CAUSES	SOLUTION
<p>Cracks in core</p> 	<p>Blade flutters in cut as a result of losing blade tension.</p> <p>Blade specification is too hard for the material being cut.</p>	<p>Tighten the blade shaft nut. Make sure blade is running at proper speed and that drive pin is functioning properly.</p> <p>Use a softer bond/matrix to eliminate stress.</p>
<p>Loss of tension</p> 	<p>Core overheating.</p> <p>Core overheating as a result of blade spinning on arbor.</p> <p>Core overheating from rubbing the material being cut.</p> <p>Unequal pressure at blade clamping collars/flanges.</p> <p>Blade is too hard for the material being cut.</p>	<p>Make certain blade RPM is correct.</p> <p>Check water flow, distribution and lines.</p> <p>Tighten the blade shaft nut. Make certain the drive pin is functioning.</p> <p>Properly align the saw to square cut.</p> <p>Collars/flanges must be identical in diameter and the recommended size.</p> <p>Use a softer bond/matrix to reduce stress.</p>
<p>Blade wobbles</p> 	<p>Blade is on a damaged or worn saw.</p> <p>Worn collar.</p> <p>Blade runs at an incorrect speed.</p> <p>Collar/flange diameters are not identical.</p> <p>Blade is bent as a result of dropping or twisting.</p>	<p>Check for bad bearings, bent shaft, or worn mounting arbor. Check collar/flange to make sure they are clean, flat and of correct diameter.</p> <p>Set engine at proper RPM. Use proper size blade collars/flanges.</p> <p>DO NOT use bent blade. Contact blade manufacturer.</p>
<p>Blade does not cut</p> 	<p>Blade is too hard for material being cut.</p> <p>Blade has become dull. Blade does not cut material it was specified for.</p>	<p>Select proper blade for material being cut.</p> <p>Sharpen by cutting on softer abrasive material to expose diamonds. If continually sharpening, the blade is too hard or the material being cut.</p> <p>Break-in on the material to be cut. If it does not dress itself, sharpen as you would a dull blade.</p>

SYMPTOM	POSSIBLE CAUSES	SOLUTION
<p>Undercutting the core</p> 	<p>Abrasive wearing of the core faster than the segments.</p>	<p>Use water to flush out fines generated during cutting. Use wear-retardant cores.</p>
<p>Arbor hole out of round</p> 	<p>Collars/flanges are not properly tightened, permitting blade to rotate or vibrate on the shaft. Collars/flanges are worn or dirty. Blade is not properly mounted.</p>	<p>Make certain the blade is mounted on the proper shaft diameter. Tighten the shaft nut with a wrench to make certain that the blade is secure. Clean collars/flanges, make sure they are not worn. Tighten arbor nut. Make sure the pin hole slides over drive pin.</p>
<p>Blade worn out of round</p> 	<p>Shaft bearings are worn. Surges occur because engine is not properly tuned. Blade arbor hole is damaged from incorrectly mounting the blade. Bond/matrix is too hard for material. Blade is slipping, wearing one half of blade more than other.</p>	<p>Install new blade shaft bearings or blade shaft, as required. Tune engine according to manufacturer's manual. DO NOT use if core is worn or arbor hole damaged. Contact blade manufacturer. Replace worn shaft or mounting arbor bushing. Make certain that drive pin is functioning. Tighten spindle nut.</p>

## 4. TECHNICAL DATA

Engine Make	Honda GX390
Horsepower	13 HP
Weight	304 lbs
Max Cutting Depth	5.5 in
Blade Size	12-18 in
Depth Adjustment	Handle Rotation
Driving	Manual Push
Water Tank Capacity	9 Gal

### Dimension:

A- 64.5 in

B- 23 in

C- 37.4 in

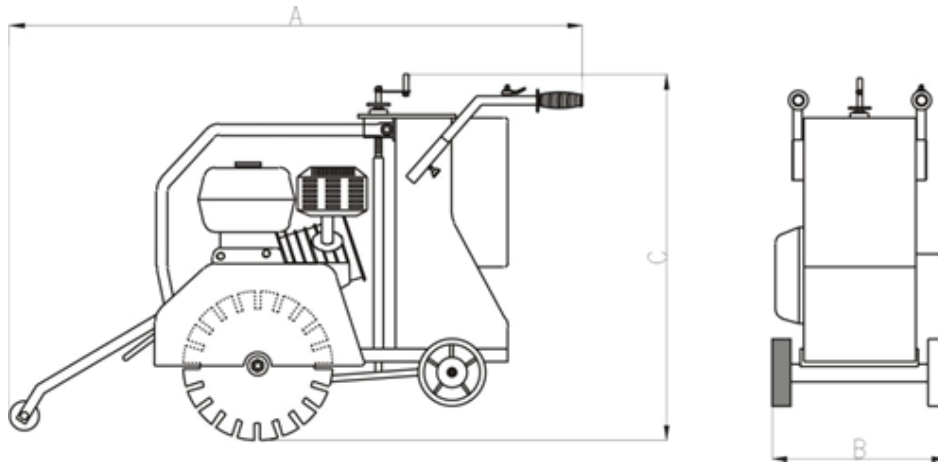

### Sound Specification (According to 2000/14/EC)

Guaranteed sound power level

**108dB(A)**

### Hand-Arm Vibration Specification (According to ISO 5394, EN 1033 and EN500-4) :

5 m/s<sup>2</sup>

## WARRANTY

Tomahawk Power products are covered by a Warranty for a period of twelve (12) months from the date of purchase against defects in material or workmanship provided that:

- The product concerned has been operated and maintained in accordance with the operating instructions.
- Has not been damaged by accident, misuse or abuse.
- Has not been tampered with or repaired by any unauthorized person.

The owner is responsible for the cost of transportation to and from the authorized repairer and the unit is at the owner's risk while in transit to and from the repairer.





**USA (866) 577-4476**

**MX 01 (800) 099 0778**

**[www.tomahawk-power.com](http://www.tomahawk-power.com)**

**[contacto@tomahawk-power.com](mailto:contacto@tomahawk-power.com)**