

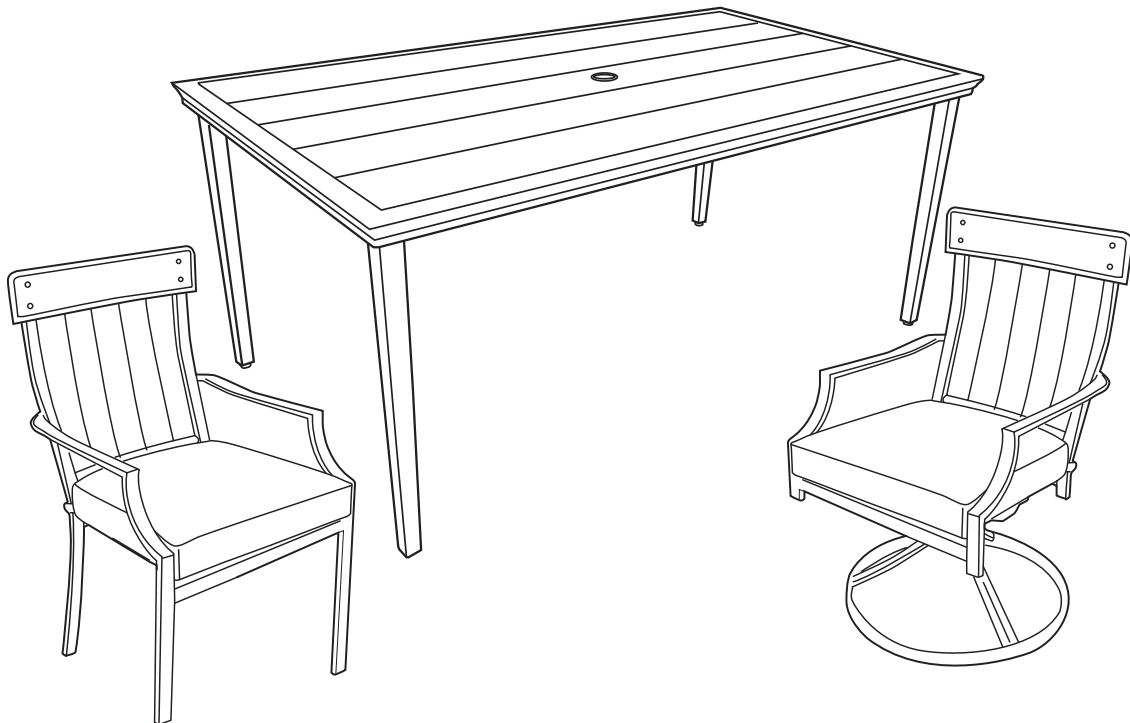

Item #1001 413 093 /  
1002 741 972 / 1002 737 156  
Model #D12237-7PC /  
D12237-7PC-B

# USE AND CARE GUIDE

## OAK HEIGHTS 7PC DINING SET



Questions, problems, missing parts? Before returning to the store,  
call Hampton Bay Customer Service  
8 a.m. - 7 p.m., EST, Monday-Friday  
9 a.m. - 6 p.m., EST, Saturday

**1-855-HD-HAMPTON**

**HAMPTONBAY.COM**



### **THANK YOU**

*We appreciate the trust and confidence you have placed in Hampton Bay through the purchase of this dining set. We strive to continually create quality products designed to enhance your home. Visit us online to see our full line of products available for your home improvement needs. Thank you for choosing Hampton Bay!*

# Table of Contents

Table of Contents .....	2	Assembly .....	6
Safety Information .....	2	Care and Cleaning.....	8
Warranty .....	2		
What is Covered .....	2		
What is Not Covered .....	2		
Pre-assembly .....	3		
Planning Assembly .....	3		
Hardware Included .....	3		
Table Package Contents .....	4		
Swivel Dining Chair Package Contents .....	5		

# Safety Information

-  **WARNING:** Do not sit or stand on the table top.
-  **WARNING:** Do not place heavy items on the table top.
-  **WARNING:** An umbrella base must be used at all times. An umbrella should not be used in the event of wind, rain, hail, sleet, snow or any other inclement weather.

# Warranty

**THIS IS A RESIDENTIAL WARRANTY AND DOES NOT APPLY FOR COMMERCIAL USE.**

## 2 YEAR FRAME AND FABRIC LIMITED WARRANTY

### WHAT IS COVERED

We warrant the frame and fabric to be free of manufacturing defects to the original purchaser for two years.

### WHAT IS NOT COVERED

It remains the customer's responsibility for freight and packaging charges to and from our service center.

This warranty does not cover commercial use, hardware, acts of nature, fire, freezing and abusive use.

In addition, purchased parts are not covered under this warranty. We reserve the right to make substitutions with similar merchandise, if the model in question is no longer in production.

For a copy of our full limited warranty, please contact our customer service team below.

Contact the Customer Service Team at 1-855-HD-HAMPTON or visit [www.hamptonbay.com](http://www.hamptonbay.com).

# Pre-assembly

## PLANNING ASSEMBLY

please read complete instruction manual prior to assembly!

Identify all parts packed in the carton against the parts list. Remove all protective materials and place the parts on a nonabrasive surface to avoid scratching.



**NOTE:** More than one person may be required to complete the assembly of this product.

## HARDWARE INCLUDED



**NOTE:** Tools not shown to actual size.

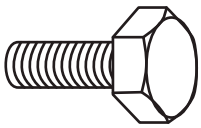

\_\_\_\_\_ AA

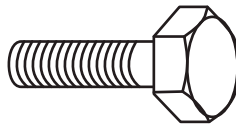

\_\_\_\_\_ BB



\_\_\_\_\_ CC



\_\_\_\_\_ DD

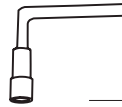

\_\_\_\_\_ EE

Part	Description	Quantity
AA	M6*15 Hex bolt	12
BB	M6*20 Hex bolt	8
CC	M6 Washer	20
DD	M6 Hex bolt cap	20
EE	Wrench	2

# Pre-assembly (continued)

## TABLE PACKAGE CONTENTS

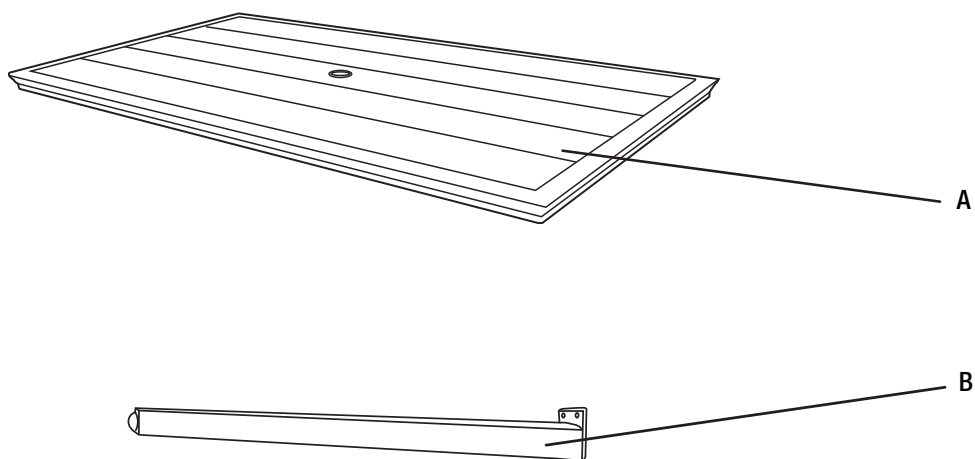

Part	Description	Quantity
A	Table top	1
B	Table leg	4

# Pre-assembly (continued)

## MOTION DINING CHAIR PACKAGE CONTENTS

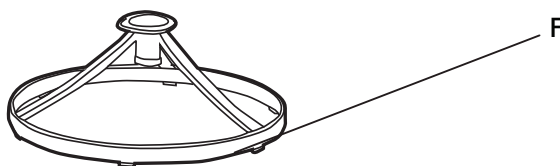
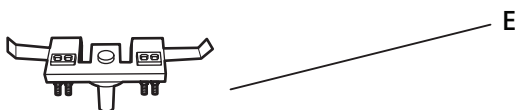
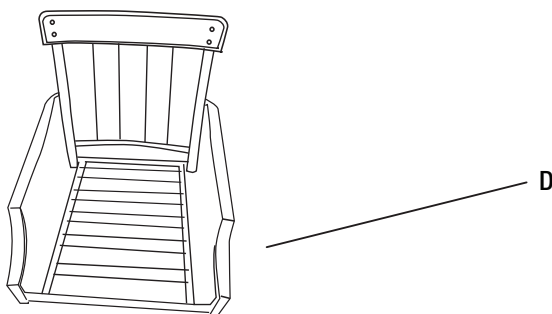
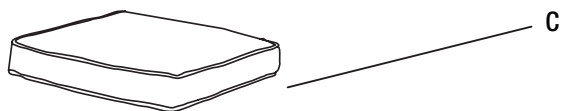

Part	Description	Quantity
C	Seat cushion	2
D	Seat frame	2
E	Stem bracket	2
F	Base	2

## 1 Attaching the table legs

- Place the table top (A) on a soft, flat non-abrasive surface.
- Attach the table legs (B) to the table top (A) using the washers (CC) and M6\*15 hex bolts (AA).
- Please ensure all the bolts are assembled correctly. Tighten all the bolts (AA) with the wrench (EE). Attach the hex bolt caps (DD).

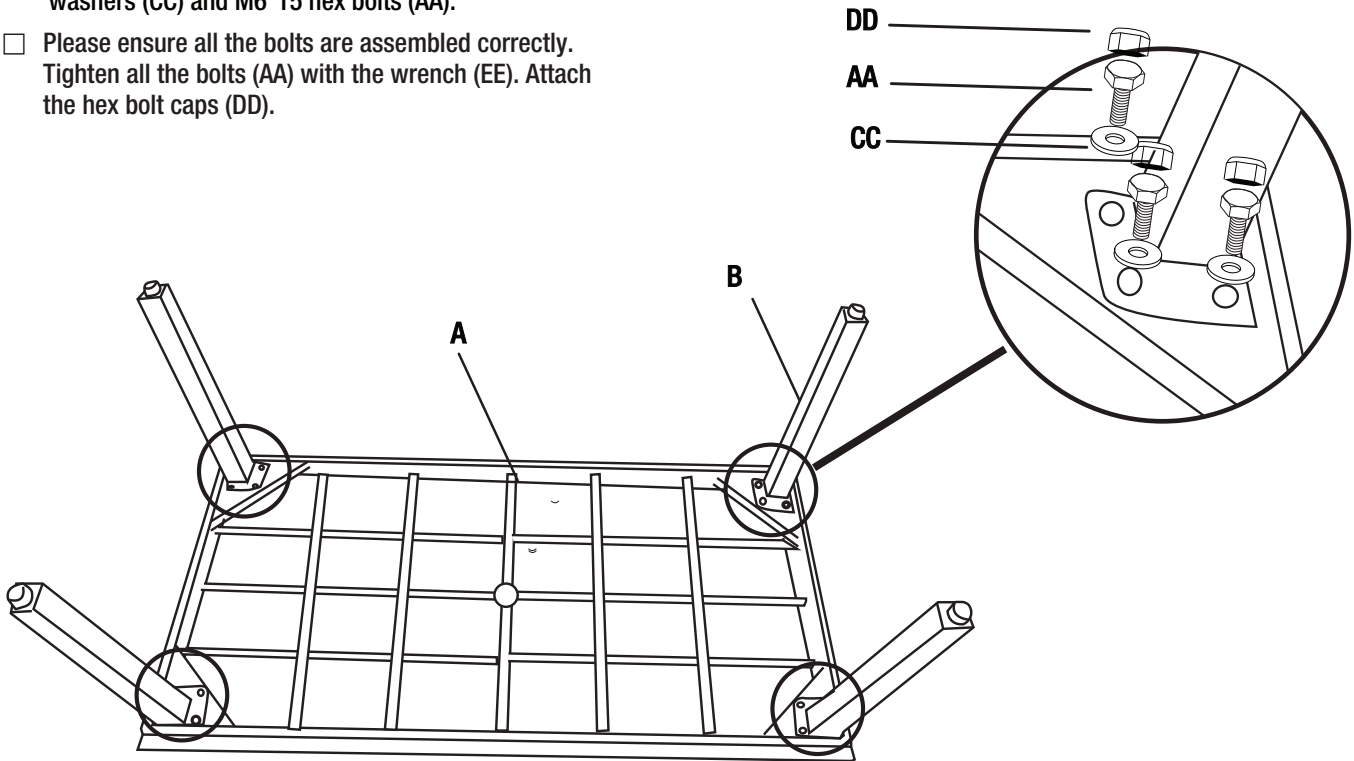

## 2 Positioning the table

- Turn the table over and set it down on its legs.
- The table is now ready for use.



## 3 Attaching the stem bracket

- Attach the stem bracket (E) to the seat frame (D) using the washers (CC) and hex bolts (BB).
- Ensure all bolts are aligned and assembled correctly.
- Tighten all hex bolts (BB) with the wrench (EE). Attach the hex bolt caps (DD).

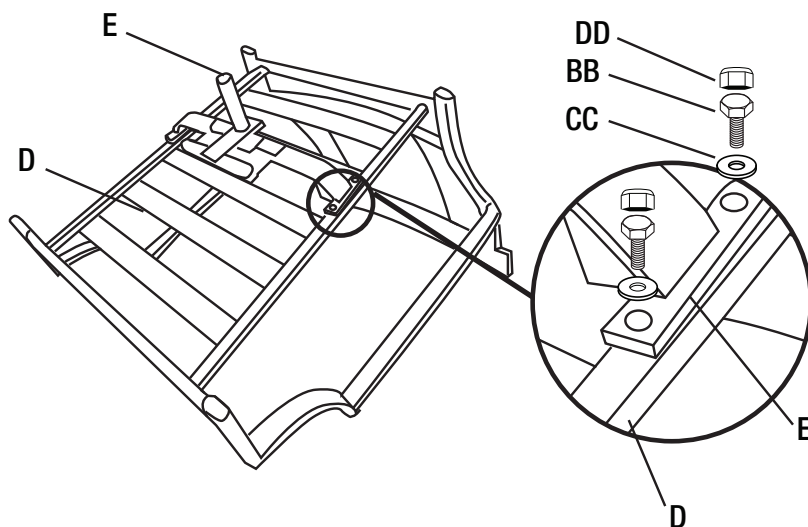

## 4 Connecting the base and seat

- Place the base (F) on a flat surface and align the stem bracket (E) under the seat frame (D) with the hole on the base (F). Push down firmly to lock the seat frame (D) and base (F) together.

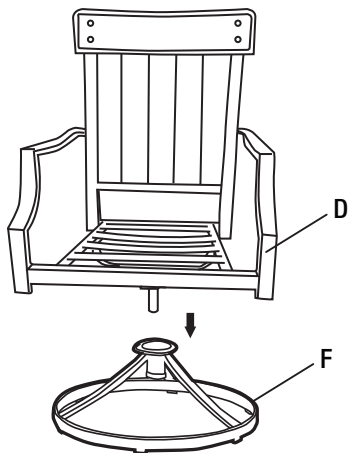

## 5 Adding the seat cushions

- Place the seat cushions (C) onto the chairs.

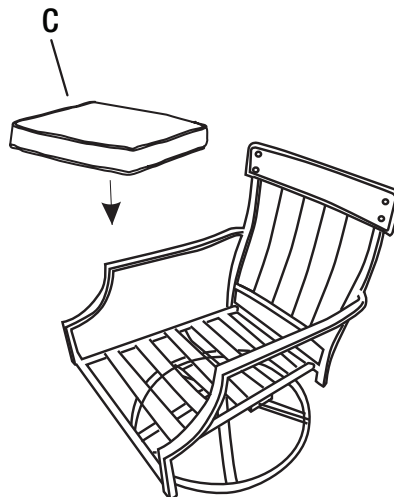

## Care and Cleaning

---

- Do not allow water to build up in the frames. This will cause corrosion and possible freezing damage in cold climates.
- Use a mild soap and water for normal cleaning. DO NOT use janitorial or alcohol based cleaners. Some cleaners may be marked as natural, but some ingredients may cause discoloration or have an adverse reaction to your finish.
- Rinse with clean water and dry with a soft, absorbent cloth towel.
- Treat frames with a liquid wax for maximum protection against UV rays and/or salty, damp air.





Questions, problems, missing parts? Before returning to the store,  
call Hampton Bay Customer Service  
8 a.m. - 7 p.m., EST, Monday-Friday  
9 a.m. - 6 p.m., EST, Saturday

**1-855-HD-HAMPTON**

**HAMPTONBAY.COM**

Retain this manual for future use.