

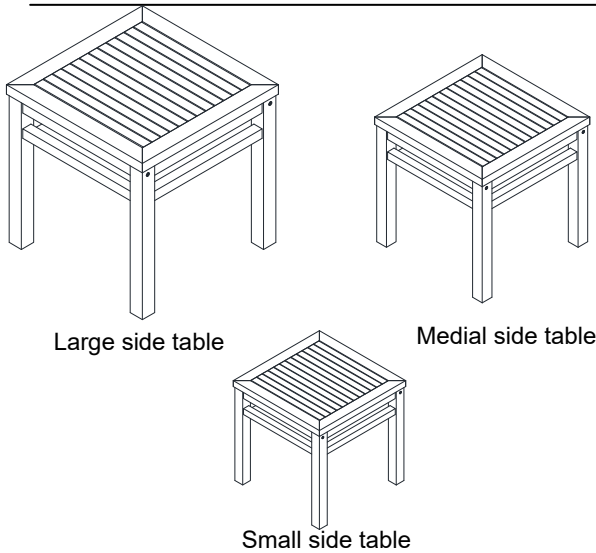

Thank you for purchasing the **MODWAY SIDE TABLE!**

Before you start, here is some helpful advice:

1. We suggest you spend a short time reading through this leaflet and then follow the simple step by step instructions.
2. Owing to the size and weight of the side table, we recommend that it is assembled by two adults, on a carpeted or padded area, in the room that it is intended for. Approximate assembly time: 30 minutes.
3. Please do not use any tools other than those provided or recommended in these instructions.
4. Please do not throw away any of the packaging or instructions until you have checked all the components and hardware and the furniture is fully assembled.
5. Assemble all components loosely until advised to tighten. Depending on use, it may be necessary to tighten the components from time to time, so please save the tools that have been provided.
6. Please keep all pieces out of reach of small children.



Hardware:

- | | | | |
|---|--|-----------------|-----|
| A |  | Bolt M6x50mm | x18 |
| B |  | Allen Wrench M4 | x1 |

Component for each large/medial/small side table:

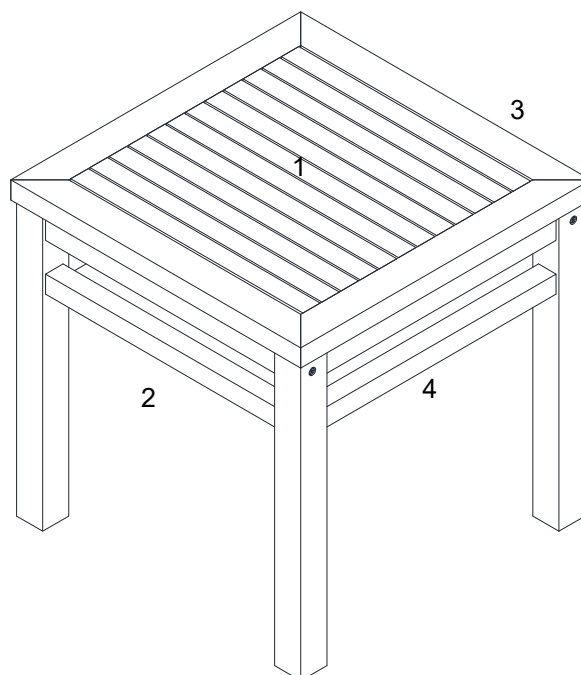

- | | | | | | |
|---|--------------------------------|----|---|-------------------------------|----|
| 1 | Large/medial/Small Table Top | x1 | 2 | Large/medial/Small Left Frame | x1 |
| 3 | Large/medial/Small Right Frame | x1 | 4 | Large/medial/Small Stretcher | x1 |

STEP 1:

Please put **Large Left Frame (2)** on a carpeted or padded area.

Insert the tenon on **Large Table Top (1)** into the rabbet on the **Large Left Frame (2)** at first.

Then insert the tenon on **Large Stretcher (4)** into the rabbet on the **Large Left Frame (2)** as shown.

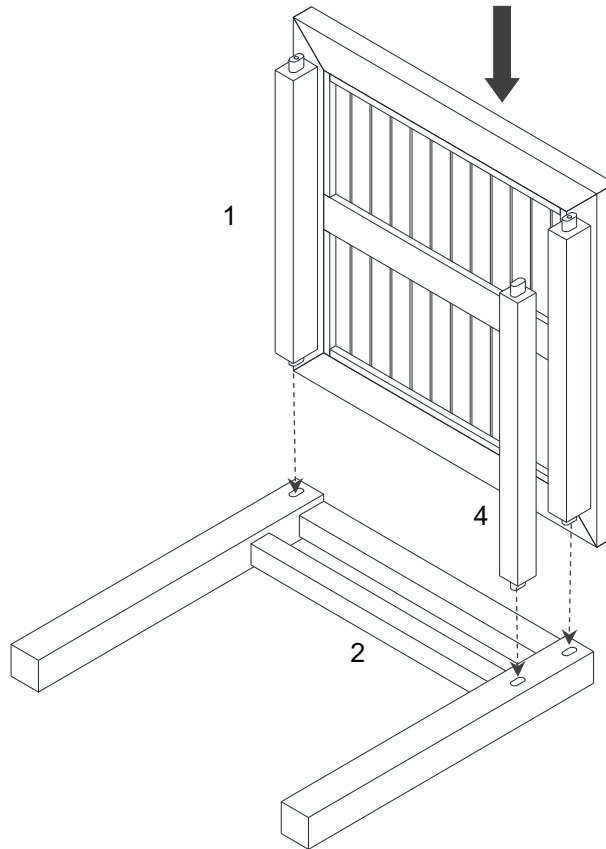

STEP 2:

Carefully position the assembled **Large Table Top (1)**, **Large Left Frame (2)** and **Large Right Frame (3)** as shown.

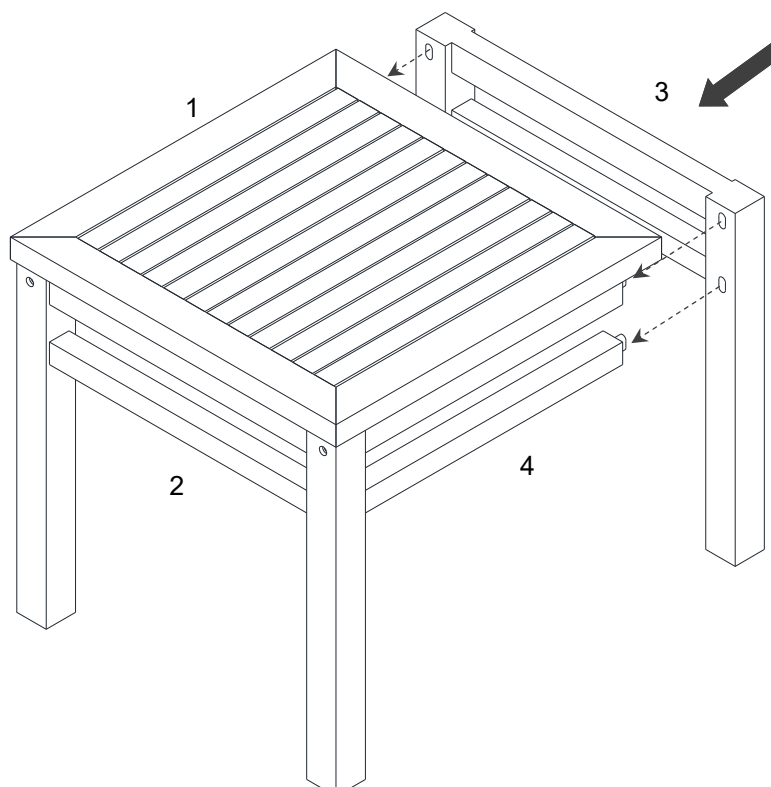

Insert the tenon on **Large Table Top (1)** and **Large Stretcher (4)** into the rabbet on the other **Large Right Frame (3)**.

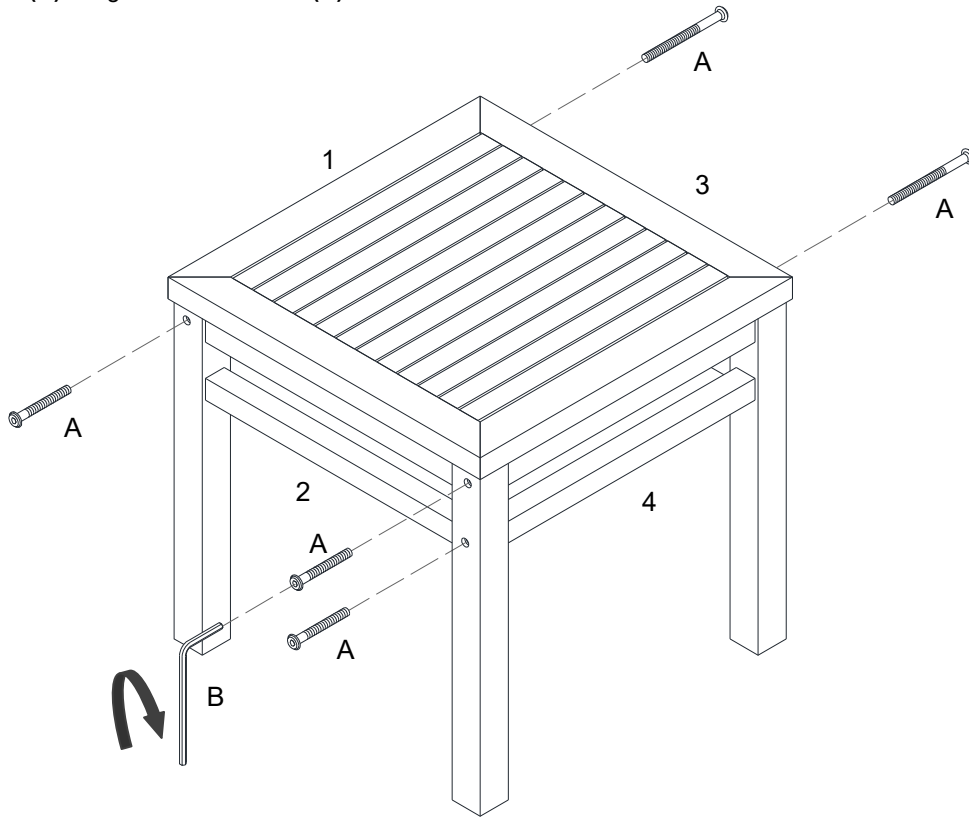

STEP 3:

Insert 4 pieces of **Bolt (A)** into pre-drilled holes on **Large Table Top (1)** through the pre-drilled holes on **Large Side Frames (2/3)**. Insert 2 pieces of **Bolt (A)** into pre-drilled holes on **Large Stretcher (3)** through the pre-drilled holes on **Large Side Frames (2/3)**. Use **Allen Wrench (B)** to tighten all the **Bolts (A)** clockwise until secure.



	
Ax6	Bx1

Hardware & Tool required

STEP 4:

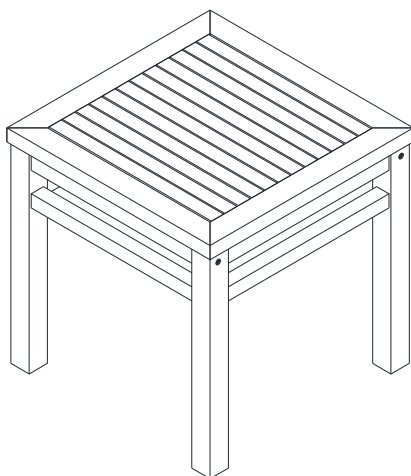

Repeat the same steps for **Media Side Table** and **Small side Table**.

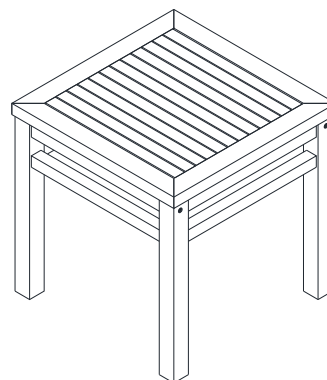

Media Side Table



Small Side Table

	
Ax12	Bx1

Hardware & Tool required

STEP 5:

Carefully position the assembled side tables to the desired location.

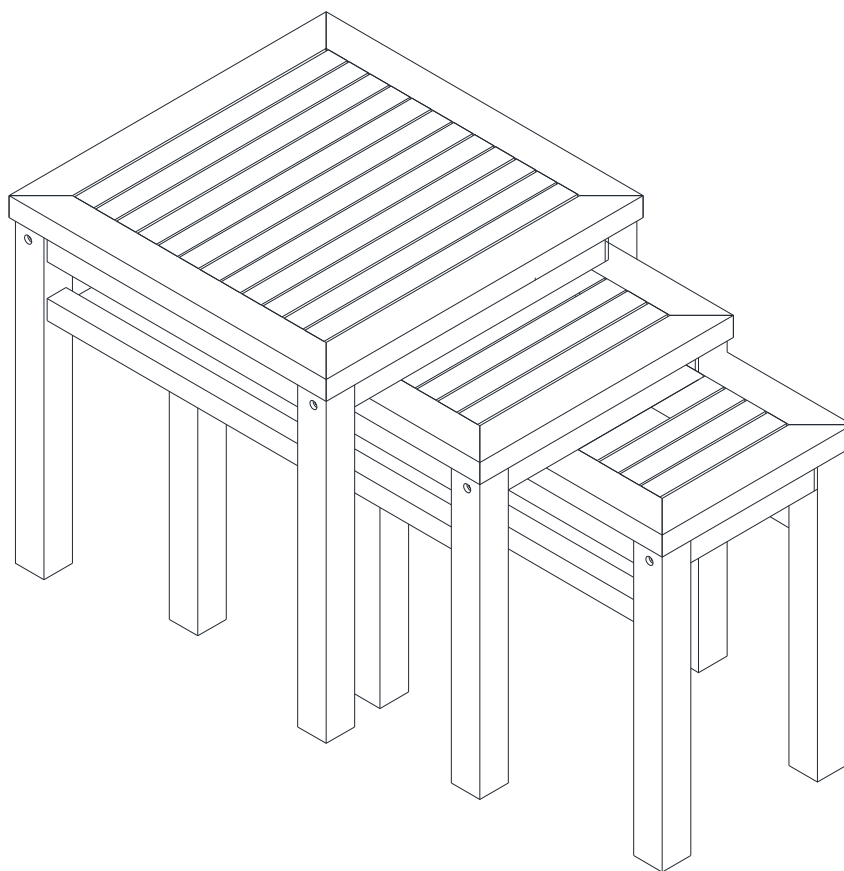

Assembly is complete. Your side tables is ready to be used now!