

# John Deere Z335M ZTrak™

## Parts and Maintenance Information

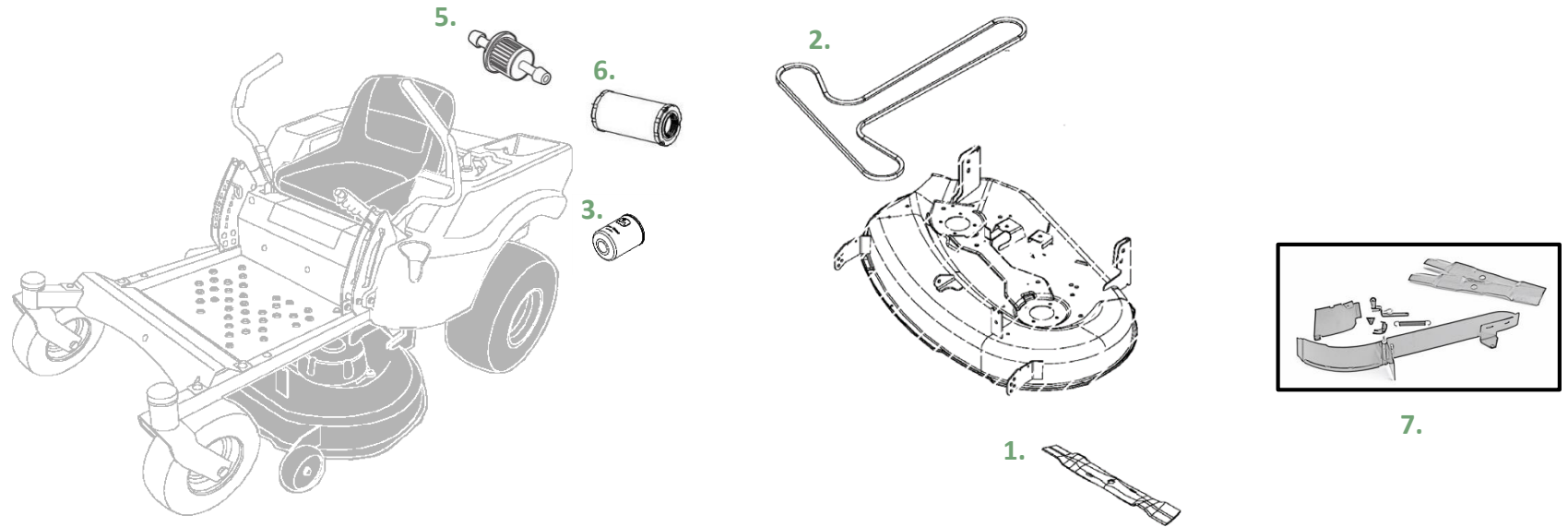

Key	Description	Part Number	THD Store SKU	THD Online SKU
1.	42 inch Mower Blade	GY20683	NA	206657632
2.	42 inch Mower Deck Belt	GX25628	NA	206657554
3.	Oil Filter	GY20577	226-963	100175070
4.	Oil	TY22029	226-971	100127512
5.	Fuel Filter	GY20709	289-625	100126418
6.	Air Filter	GY21435	876-771	202722487
7.	MulchControl™ Kit	BM24794	1002835198	206639047

# John Deere Z335M ZTrak™

## Parts and Maintenance Information

- Service Intervals

After 8 Hours	Every 100 Hours or Annually (Whichever Comes First)
Check mower deck level	Replace air filter element(s)
Every 50 hours or Annually (Whichever Comes First)	Replace fuel filter
Change engine oil	Check mower belt
Change engine oil filter	Sharpen / replace mower blades
Lubricate mower deck spindles	Clean underside of deck
Lubricate mower idler arm	Check tire pressure
Check mower deck level	Clean engine cooling fins
	Every 200 Hours
	Check / adjust engine valve clearance. See your John Deere dealer for this service.

For complete parts information for ZTrak™ Mowers: Visit your local John Deere Dealer or [www.Deere.com](http://www.Deere.com)

\*Refer to Operators Manual for a complete listing of service intervals.