

INSPIRED

BY

**Bassett**<sup>®</sup>

Tradition Reinvented™

Item# BP-ALMCSL

## ALMERIA STORAGE CONSOLE

ASSEMBLY INSTRUCTIONS

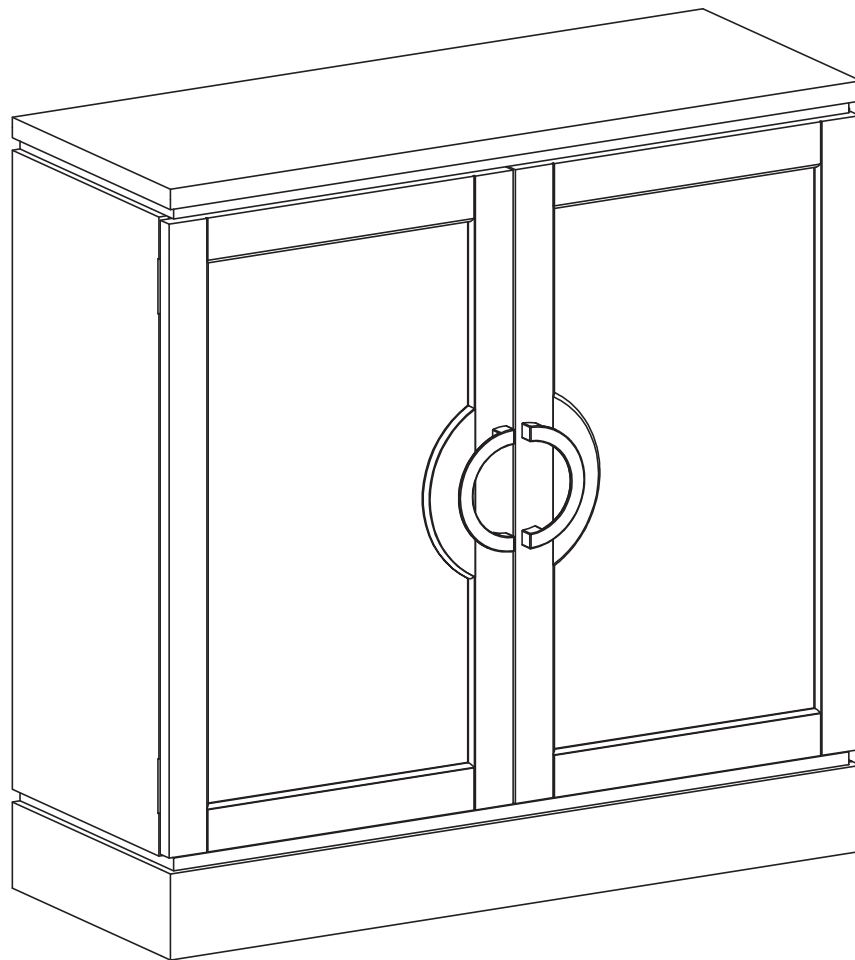

**IF PARTS ARE MISSING OR DAMAGED, DO NOT RETURN TO STORE**

To order missing or replacement parts, contact us via e-mail [parts@officestar.net](mailto:parts@officestar.net), by Fax 1-909-930-5629, or toll free parts number 1-800-950-7262, Monday through Friday 8:00 a.m. - 5:00 p.m. Pacific Time.

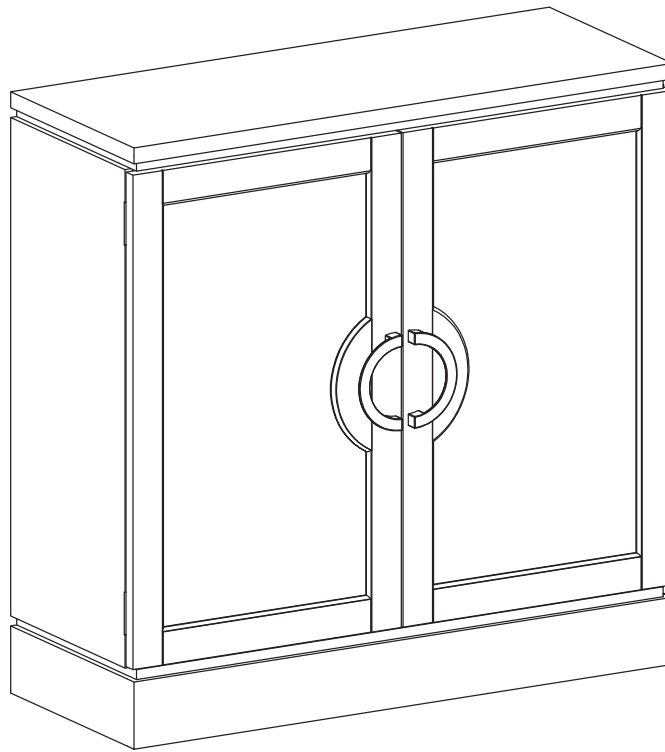

#### ***FURNITURE CARE:***

- Dust with a soft cloth following the grain pattern of the wood.
- Dust often to remove the everyday abrasive particles from the wood surfaces.
- Before dusting, moisten cloth lightly with a spray product.
- Wood finishes also benefit from an occasional polishing.

#### ***WARNING***

1. Do not use this product unless all screws and bolts are securely tightened.
2. Check that all screws and bolts are tight every three months or as needed.
3. Dispose of packing material properly. Do not use plastic cover as head covering. It may cause suffocation.
4. Do not use this product as a stepladder.
5. Use this product for its intended purpose only.
6. **Intended for residential use only.**

#### ***LIMITED WARRANTY***

INSPIRED by Bassett® Warrants, to the original purchaser its products to be free from defects in material and workmanship for a period of 5 years. Defects and damage from misuse, abuse, negligence, alteration, accident, vandalism, rusting, acts of nature or any other event beyond the control of INSPIRED by Bassett® is not covered. The warranty does not cover cosmetic damage that may result from normal use. Liability for incidental or consequential damages is excluded. The user assumes all risk of injury resulting from use of this product. This warranty gives you specific legal rights, and you may also have other rights which vary from state to state.

To make a warranty claim, contact Customer Service, provide model number, sales receipt and description of the problem. It is the customer's responsibility to prepay freight on any components returned to the factory. INSPIRED by Bassett® will pay return freight on components covered under terms of warranty.

Contact us via e-mail [parts@officestar.net](mailto:parts@officestar.net), by Fax 1-909-930-5629, or toll free parts number 1-800-950-7262, Monday through Friday 8:00 a.m. - 5:00 p.m. Pacific Time.

**THANK YOU** for purchasing this quality product. Be sure to check all packing material carefully for small parts which may have come loose inside the carton during shipment. Identify and count all parts and compare with the parts and hardware lists.

# PARTS LIST

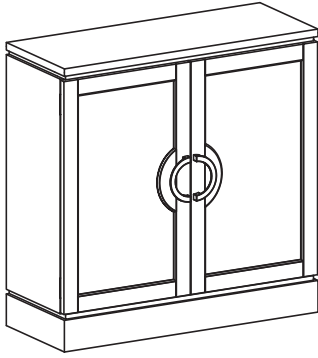

(1) Console (1 PC)



(2) Shelf (1 PC - Preinstalled)

# HARDWARE LIST

NO	DRAWING	DESCRIPTION	SIZE	QTY.
A		Anti-Tip Kit	n / a	1 PC

## STEP 1:

To re-position Shelf (2), remove screws from shelf pins. Re-position shelf pins to desired height, install Shelf (2) and secure to shelf pins using pre-existing screws. **FULLY TIGHTEN ALL SCREWS. IF NEEDED, ADJUST LEVELERS TO LEVEL CONSOLE.**

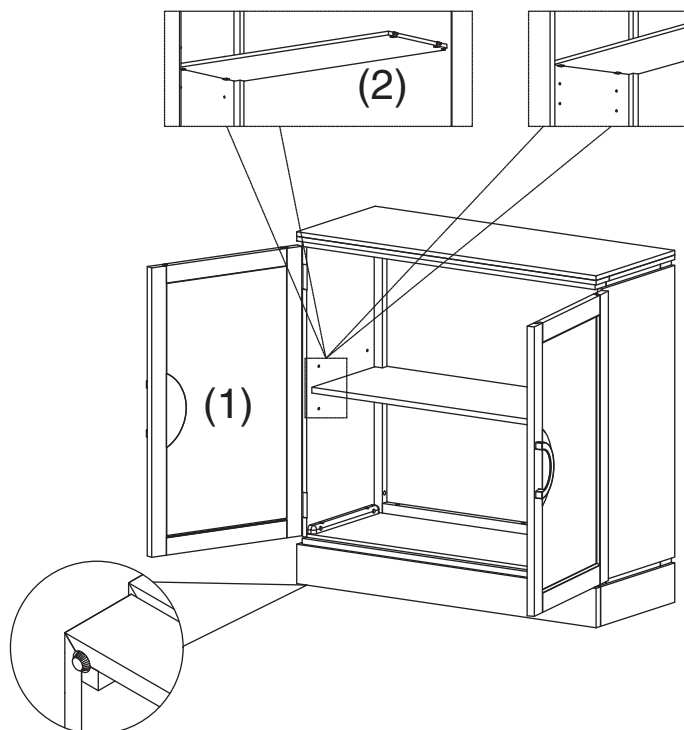

**STEPS:**

Place cabinet in desired location. Secure one Bracket to wall using one Long Screw, **FULLY TIGHTEN LONG SCREW USING PHILLIPS SCREWDRIVER (not provided)**. Secure remaining Bracket to rear of cabinet using one Short Screw, **FULLY TIGHTEN SHORT SCREW USING PHILLIPS SCREWDRIVER (not provided)**. Loop Safety Strap through Brackets and fasten Safety Strap.

