



## OPERATION MANUAL



**CZ500**  
Misting Fan

Specifications/Features .....3

Warnings/Introduction .....4

Installation Instructions .....5

Special Instructions .....6

Settings and Adjustments .....7

Cleaning and Maintenance .....8

Troubleshooting.....9

Warranty Information ..... 10-11

## LIMITED ONE YEAR WARRANTY



**WARRANTY:** The Company warrants this product to the original purchaser or gift recipient, to be free from defects in workmanship and material under normal use and service, for a period of one year from the date of purchase.

**LIMITATIONS:** ALL WARRANTIES IMPLIED BY LAW, INCLUDING THE IMPLIED WARRANTIES OF MERCHANTABILITY AND FITNESS FOR A PARTICULAR PURPOSE, ARE EXPRESSLY LIMITED TO THE DURATION OF THE LIMITED WARRANTIES SET FORTH ABOVE. IN NO EVENT SHALL THE COMPANY BE LIABLE FOR ANY INCIDENTAL OR CONSEQUENTIAL DAMAGES, LOSS OF PROFIT OR MEDICAL EXPENSES CAUSED BY ANY DEFECT, FAILURE, MISUSE OR MALFUNCTION OF THIS PRODUCT.

Some jurisdictions do not allow the exclusion or limitation of incidental or consequential damages, so these limitations or exclusions may not apply to you. The Company will not be responsible for damages or losses, direct or indirect, caused by misuse, abuse, accident, negligence, product alteration, connecting to an improper electrical supply, acts of God, conditions of transportation or storage, or failure to follow instructions including the use of non-distilled water. The Company will not be responsible for any statements that are made or published, written or oral, that are inconsistent with this written warranty, or which are misleading or inconsistent with the facts as published in the literature or specifications by the company.

**WARRANTY CLAIM PROCEDURE:** Any product that proves to be defective within the warranty period must be delivered to the nearest SUNHEAT Warranty Service Center or to the address below. All transportation charges are the responsibility of the consumer. A copy of the original receipt must accompany all warranty claims.

SUNHEAT International  
 3724 Arch Ave  
 Grand Island, NE 68803  
 877-467-8643  
[www.sunheat.com](http://www.sunheat.com)

**WARRANTY CARD**  
SUNHEAT International  
3724 Arch Ave.  
Grand Island, NE 68803  
877-467-8643

**TO REGISTER WARRANTY ONLINE OR FOR  
DEALER INQUIRIES GO TO**

**www.sunheat.com**

**OR**

**CLIP AND RETURN THE WARRANTY CARD BELOW.**

---

**Cool Zone Warranty Registration**

**Please return this card within 30 days of purchase to  
activate your warranty.**

**THANK YOU**

NAME: \_\_\_\_\_ PHONE: \_\_\_\_\_  
ADDRESS: \_\_\_\_\_  
CITY: \_\_\_\_\_ STATE: \_\_\_\_\_ ZIP: \_\_\_\_\_  
EMAIL ADDRESS: \_\_\_\_\_  
DEALER PURCHASED FROM: \_\_\_\_\_  
DEALER'S ADDRESS: \_\_\_\_\_  
DEALER'S PHONE: \_\_\_\_\_  
MODEL #: \_\_\_\_\_ SERIAL #: \_\_\_\_\_  
DATE PURCHASED: \_\_\_\_\_

I am interested in becoming a SUNHEAT dealer. Please send me  
information. \_\_\_\_\_

**SPECIFICATIONS**

Model	CZ500
Rated Voltage	110V~
Speed 1	47 watts
Speed 2	51 watts
Speed 3	55 watts
Swing	Adds 2 watts
MAX Humidity	10.1oz./h
Blade Diameter	15.75"
Water Tank Capacity	1.69 quarts
Dimensions in Inches	17.5" x 14.75" x 51.5"
Gross Weight	20 lbs.

**PRODUCT FEATURES**

- 3 Fan Speeds
- Oscillating and tilt fan
- Anion Ionizer
- Sleep Mode
- Mosquito Repellent
- Remote Control
- Wheels
- "Dry" mist
- Extra Large 20" Blade
- Aromatherapy Dispenser



## CAUTION



- To reduce the risk of electric shock, keep plug away from water
- Do not touch ultrasonic atomizer while operating, may result in injury
- Keep small objects away from fan guard and mist cover to prevent damage
- The water level switch will automatically turn off to protect the MIST function if the water level is too low
- Water put into the tank should be less than 40° Fahrenheit
- Do not put metals and chemicals into the tank, this is dangerous and will harm the mist function
- Before replacing mosquito incense, turn the mosquito function to off for at least 5 minutes
- Keep flammable items away from the mosquito repellent
- Infants, elderly, or those who are weak should not sit directly in the airflow for extended periods of time
- Damaged power cords should be replaced by the manufacturer, maintenance department, or other qualified professional to avoid harm

Welcome!

This mist fan with its unique appearance and exquisite workmanship is easy to operate. Functions include an oscillating fan, ultrasonic humidifier, mosquito repellent, ice gel pack insert, anion, aromatherapy, and temperature display. These seven functions can be used in unison or independently of one another. The mist fan can help you to stay cool during the hot season and keeps your air comfortably humid during the dry season to create a natural and relaxing environment.

## TROUBLESHOOTING

Problem	Possible Causes	Solution
Unit is on but not working	<ol style="list-style-type: none"> <li>1. The motor does not work</li> <li>2. The voltage is too low</li> <li>3. The spindle of the motor is locked</li> <li>4. The circuit board is broken</li> <li>5. The capacitor is not working</li> </ol>	<ol style="list-style-type: none"> <li>1. Start high speed</li> <li>2. Increase the rated voltage</li> <li>3. Attempt to pull the motor cover from its jammed position</li> <li>4. Have the circuit board replaced</li> <li>5. Inspect the welding of the capacitor or install a new capacitor</li> </ol>
Fan out of balance	<ol style="list-style-type: none"> <li>1. Rear fan guard is loose</li> <li>2. Blade screw is loose</li> <li>3. Blade is unstable or broken</li> <li>4. Blade is unbalanced</li> </ol>	<ol style="list-style-type: none"> <li>1. Tighten the fan guard</li> <li>2. Tighten the blade screw</li> <li>3. Replace the blade</li> <li>4. Turn the blade 180° then install</li> </ol>
Atomizer is running but there is no mist	<ol style="list-style-type: none"> <li>1. The water in the tank is alkaline</li> <li>2. The water tank is broken or cracked</li> </ol>	<ol style="list-style-type: none"> <li>1. Clean water tank, spray barrel and sink several times</li> <li>2. Empty the water from the sink and replace the tank</li> </ol>
Atomizer is not working	<ol style="list-style-type: none"> <li>1. The float is not up</li> </ol>	<ol style="list-style-type: none"> <li>1. Manually pull float up</li> </ol>
Indicator light is on, fan and mist are not working	<ol style="list-style-type: none"> <li>1. Fan is unplugged</li> <li>2. Power switch is off</li> </ol>	<ol style="list-style-type: none"> <li>1. Connect the plug</li> <li>2. Turn the mist switch on</li> </ol>
Indicator light is on, mist is not working	<ol style="list-style-type: none"> <li>1. No water in the tank</li> <li>2. Mist switch is off</li> <li>3. The float is loose</li> </ol>	<ol style="list-style-type: none"> <li>1. Fill the water tank with distilled water</li> <li>2. Turn on the switch</li> <li>3. Tighten the float</li> </ol>
Foul odor from mist	<ol style="list-style-type: none"> <li>1. New product, first use</li> <li>2. Internal tank needs cleaned</li> </ol>	<ol style="list-style-type: none"> <li>1. Open tank cap and store the tank in a cool, dry location</li> <li>2. Clean the tank and replace the water</li> </ol>
Other problems	<ol style="list-style-type: none"> <li>1. Charred smell from motor</li> <li>2. Exposed wire, damaged insulation</li> <li>3. Rear motor shell is hot</li> <li>4. Rear motor shell is broken and fan guard is damaged</li> </ol>	<ol style="list-style-type: none"> <li>1. Stop using, send for maintenance</li> <li>2. Stop using, send for maintenance</li> <li>3. Turn fan off and let it cool down</li> <li>4. Send to replace the parts</li> </ol>

## CLEANING AND MAINTENANCE

- Turn power off and unplug before cleaning
- Clean water tank once a week
- Take out water tank and separate mist pipe, spray cone if humidifier needs cleaned
- Empty excess water and use detergent for hard water stains inside the sink, dry with a cloth
- Put 2-3 drops of machine oil in the motor shaft
- Store fan in a cool and dry place

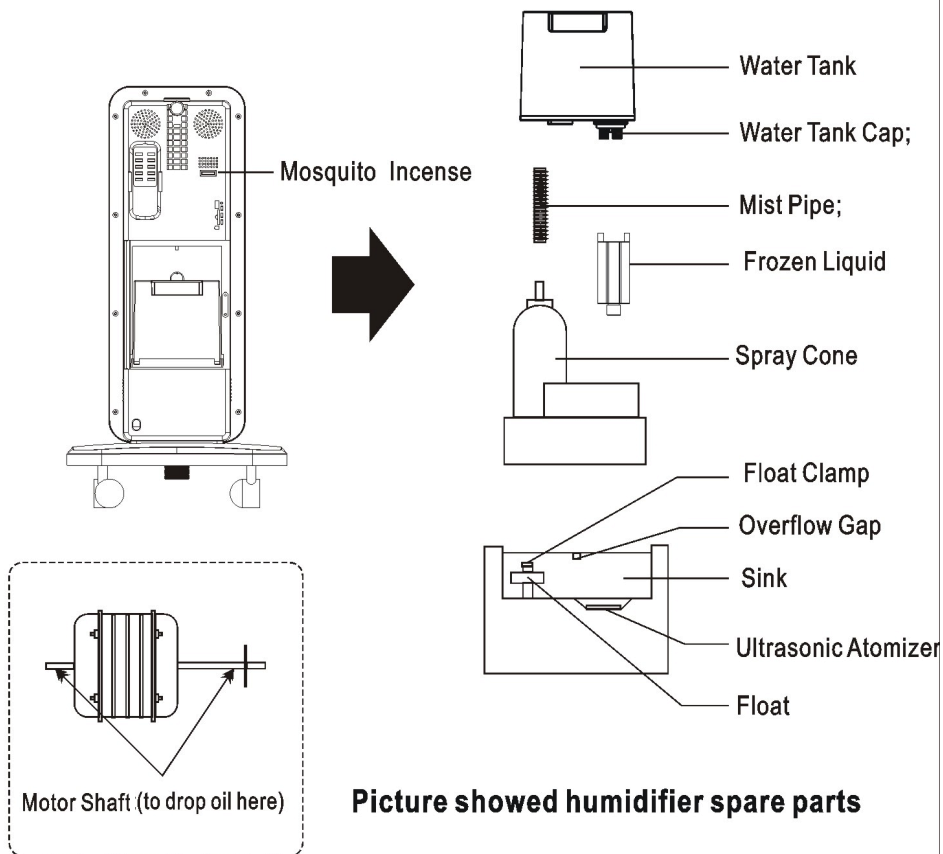

## INSTALLATION

1. Aromatherapy cover
2. Aromatherapy box
3. Front mist cover
4. Rear mist cover
5. Front fan guard
6. Fan blade lock
7. Fan ring
8. Fan blade
9. Guard lock
10. Rear fan guard
11. Motor
12. Positioning knob
13. Fan body
14. Base
15. Castor
16. Base lock
17. Anion hole
18. Mist pipe
19. Mist connector

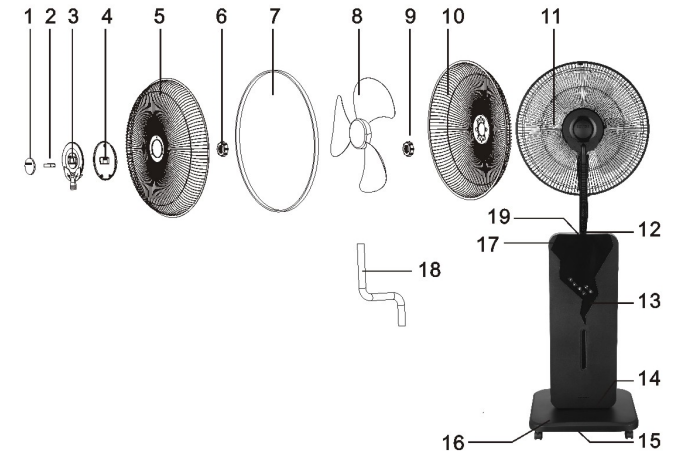

**According to the above installation diagram, install as follows:**

**Step 1:** Insert the castor (#15) into the base (#14)

**Step 2:** Insert the motor (#11) into the fan body (#13) and position the knob (#12) to fixed motor (#11)

**Step 3:** Insert fan body (#13) into the base (#14) and tighten the base using the base lock (#16)

**Step 4:** Attach rear fan guard (#10) to the motor (#11) and tighten guard lock (#9)

**Step 5:** Insert fan blade (#8) into the motor shaft, then tighten the fan blade lock (#6) by turning it counterclockwise

**Step 6:** Attach the front fan guard (#5) to the fan ring (#7) and align with rear fan guard (#10) pressed and secured into front fan guard (#5)

**Step 7:** Insert one side of the mist pipe (#18) into the front mist cover (#3) and attach the other side to the mist connector (#19)

## HOW TO ADD WATER

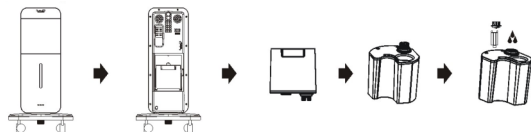

Step 1: Open the door as shown in diagram

Step 2: Remove the tank by pulling it upward, take care not to spill water

Step 3: Turn the water tank so that the bottom side is facing upwards

Step 4: Remove the tank cover as shown and add distilled water to the tank. If desired, add ice cubes to the tank, screw on the tank cover, then flip the tank and return it to the fan body, ensuring that it is balanced.

## REMOTE CONTROL INSTRUCTIONS

Plug in the fan, and check that the indicator is on. Point the remote control at the receiving screen on the panel and press the function keys to select which function you would like to run.

- ON/SPEED** Press once to start the fan then push again to adjust speed. It will show speeds 1, 2, and 3.
- SWING** Press once, “swing” signal will turn on and the fan will oscillate 180°.
- TIMING** Push to set the time that you need up to 8 hours in 1 hour increments. The LED display will reflect your selection.
- WIND** Three settings:  
**Normal:** The default setting, will operate the 1, 2, or 3 speed.  
**Natural:** Simulates real wind with varying power levels.  
**Sleeping:** The fan will adjust from middle natural and weak natural in half hour increments until the preset time is completed.
- ANION** Powers on the negative ion generator. When the indicator light is on it will release negative ions to purify the air.
- SPRAYING** This activates the humidifier, the indicator light will activate and mist will be released. This can work with the fan to cool the air or be used alone.
- MOSQUITO REPELLENT** Turns on/off the mosquito repellent function, can be used alone or with other functions. Call 877-GO-SUNHEAT for replacement mosquito mats.
- OFF** This will shut off all functions, the anion function can be used while all other functions are off.

The remote control should be pointed toward the receiver if using. If it is not working check the battery power and/or replace the batteries.



## SETTINGS AND ADJUSTMENTS

- Humidifying Function** Uses ultrasonic high frequency oscillation principles to atomize the water into 1-5 micron ultrafine particles through the pneumatic setting, then diffuses the water into the air, making the air more humid.
- Mosquito Repellent Function** Utilizes and distributes incense to achieve a repellent effect when the metal plate is heated evenly.
- Ice gel pack Function** Cools the water using inserted ice cubes.
- Anion Function** Uses an anion generator which uses a pulse and a high oscillation circuit in order to produce corona and oxygen molecules. These will effectively produce reactive oxygen species and sterilize the air.
- Temperature Display Function** Electronic thermal sensors detect indoor temperatures, will work in unison with the fan, and there is no switch for this function.
- Waterless Alarm** Utilizes a sensor in order to control the water level, if the water level is too low the alarm will sound three times, “DRY” signal on the display will flash, and the spraying function will not work due to automatically disconnected power.

## HEALTHY HUMIDITY

A dry environment can lead to a loss of excessive body water and accelerates aging. Moist air can keep vitality. Keep a comfortable level of 45%RH-65%RH under various conditions in order to look and feel better. The ultrasonic mist fan will help to achieve this goal and create a comfortable environment.