







Examine all packaging material for small parts that may have come loose during shipment. Periodic checks are recommended to insure that all components are in proper position, tight and free from damage. Keep this assembly instruction for future reference. Adult assembly is required. The product of Hillsdale Furniture, LLC is designed for residential use only. Customer Service Phone Number: 502-562-0000

HARDWARE LIST

- A(14) Allen Bolts M6 x 50mm
- B (4) Allen Bolts M6 x 40mm
- C (4) Allen Bolts M6 x 35mm
- D(22) Spring Washers
- E (4) Small Flat Washers
- F(18) Large Flat Washers
- G (1) Allen Wrench

| PART | QTY | HARDWARE | PART | QTY | HARDWARE |
|------|-----|--|------|-----|---|
| A | 14 |  | B | 4 |  |
| C | 4 |  | D | 22 |  |
| E | 4 |  | F | 18 |  |
| G | 1 |  | | | |

PARTS LIST

- K (1) Stool Back
- L (1) Seat Base
- M (4) Legs
- N (1) Top Support Ring
- P (1) Bottom Support Ring

STEP 1

Begin the assembly by attaching the Seat Base (L) to the Stool Back (K). Once in place, secure each arm of the Stool Back (K) using 3 Allen Bolts (A), 3 Spring Washers (D) & 3 Large Flat Washers (F) per side. Tighten all bolts using the Allen Wrench (G).

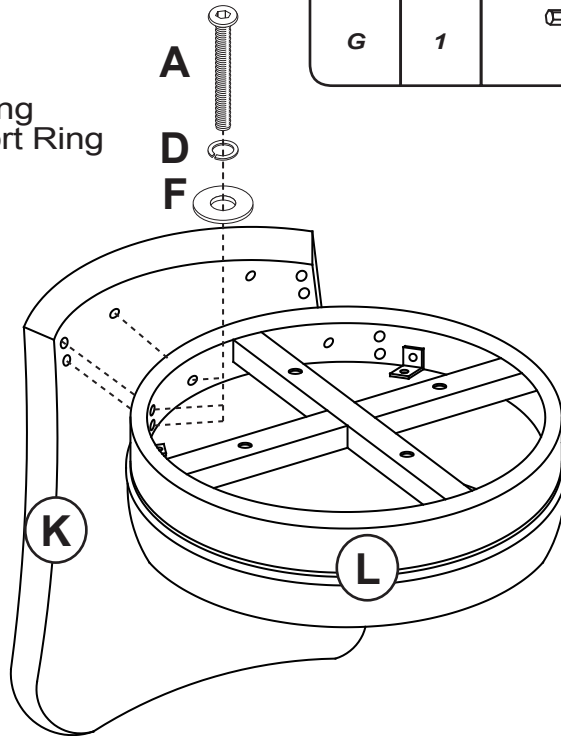
STEP 2

Attach each Leg (M) to the Top Support Ring (N). During assembly, secure from inside by using 2 Allen Bolts (A), 2 Spring Washers (D) & 2 Flat Washers (F). Do not tighten bolt on this step.

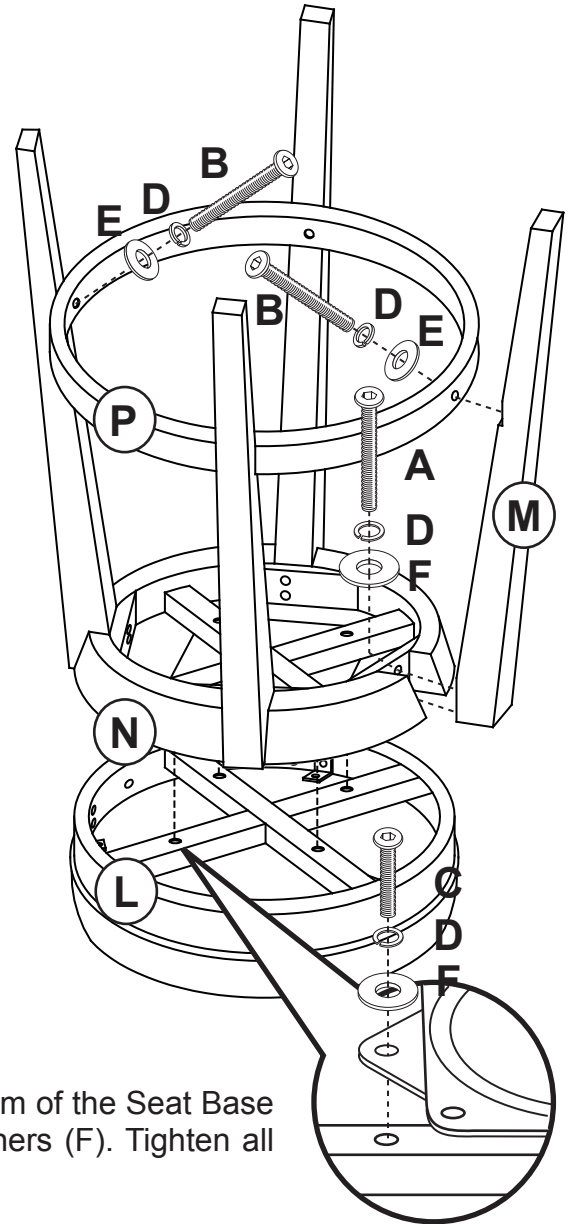
STEP 3

Now slowly attach the Bottom Support Ring (P) into assemble Leg (M) by using 1 Allen Bolt (B), 1 Spring Washer (D) & 1 Flat Washer (E) per each Leg. Now tighten all Bolts from Step 3 to 4.

STEP 4

Attach the Metal Plate from the Top Support Ring (N) to the bottom of the Seat Base (L) using 4 Allen Bolts (C), 4 Spring Washers (D) & 4 Flat Washers (F). Tighten all bolts. The assembly is now complete.